

## Base Prospectus dated 10 May 2019



Cassa depositi e prestiti S.p.A.  
(incorporated with limited liability in the Republic of Italy)  
Euro 10,000,000,000  
Debt Issuance Programme

Under the Debt Issuance Programme described in this Base Prospectus (the "**Programme**"), Cassa depositi e prestiti S.p.A. (the "**Issuer**" or "**CDP**"), subject to compliance with all relevant laws, regulations and directives, may from time to time issue Euro Medium Term Notes (the "**Notes**"). The aggregate nominal amount of the Notes outstanding will not at any time exceed Euro 10,000,000,000 (or its equivalent in other currencies). The maximum aggregate principal amount of Notes which may be outstanding at any one time under the Programme may be increased from time to time, subject to compliance with the relevant provisions of the Dealer Agreement as defined under "Subscription and Sale".

The Notes issued under this Programme may be issued in such denominations as may be agreed between the Issuer and the relevant Dealer(s) (as defined under "General Description of the Programme") save that the minimum denomination of each Note will be Euro 100,000 (or, if the Notes are denominated in a currency other than Euro, the equivalent amount in such currency). The Notes may be issued on a continuing basis to one or more of the Dealers specified hereunder and any additional Dealer appointed under the Programme from time to time by the Issuer (each a Dealer and together the Dealers), which appointment may be for a specific issue or on an ongoing basis. References in this Base Prospectus to the relevant Dealer shall, in the case of an issue of Notes being (or intended to be) subscribed by more than one Dealer, be to all Dealers agreeing to subscribe such Notes.

This Base Prospectus has been approved by the *Commission de Surveillance du Secteur Financier* (the "**CSSF**") which is the competent authority under the Luxembourg Act dated 10 July 2005 on prospectus for securities, for the purpose of Directive 2003/71/EC, as amended or superseded, (the "**Prospectus Directive**") and relevant implementing measures in Luxembourg, as a base prospectus issued in compliance with the Prospectus Directive and relevant implementing measures in Luxembourg for the purpose of giving information with regard to the issue of the Notes issued under the Programme described in this Base Prospectus during the period of twelve months after the date hereof. By approving this Base Prospectus, the CSSF assumes no responsibility for the economic and financial soundness of the transactions contemplated by this Base Prospectus or the quality or solvency of the Issuer in accordance with Article 7(7) of the Luxembourg Act dated 10 July 2005, as amended, on prospectus for securities. Application has been made to the Luxembourg Stock Exchange for the Notes issued under the Programme to be admitted during the period of twelve months after the date hereof to listing on the Official List and to trading on the regulated market of the Luxembourg Stock Exchange (a regulated market for the purposes of Directive 2014/65/EU).

References in this Base Prospectus to Notes being "listed" (and all related references) shall mean that such Notes are intended to be admitted to trading on the Luxembourg Stock Exchange's regulated market and have been admitted to the Official List of the Luxembourg Stock Exchange.

Amounts payable under the Notes may be calculated by reference to EURIBOR, which is provided by the European Money Markets Institute, to LIBOR, which is provided by ICE Benchmark Administration Limited, and to the CMS Rate, which may be provided by, among others, the administrator of LIBOR, in each case as specified in the relevant Final Terms. As at the date of this Base Prospectus, ICE Benchmark Administration Limited appears, and the European Money Markets Institute does not appear, on the register of administrators and benchmarks established and maintained by the European Securities and Markets Authority ("**ESMA**") pursuant to Article 36 of Regulation (EU) 2016/1011 (the "**Benchmarks Regulation**"). As far as the Issuer is aware, the transitional provisions in Article 51 of the Benchmarks Regulation apply, such that the European Money Markets Institute and ICE Benchmark Administration Limited are not currently required to obtain authorisation or registration (or, if located outside the European Union, recognition, endorsement or equivalence).

The Programme also permits Notes to be issued on the basis that they will not be admitted to listing, trading and/or quotation by any listing authority, stock exchange and/or quotation system, or to be issued on the basis that they will be admitted to listing, trading and/or quotation by such other or further stock exchanges, markets and/or quotation systems as may be agreed between the Issuer and the relevant Dealer.

Notes will be issued by the Issuer to raise funds for its general funding purposes or, if so specified in the applicable Final Terms, for financing or refinancing green, social or sustainable projects, as the case may be, in accordance with the principles set out by the International Capital Market Association ("**ICMA**") (respectively, the Green Bond Principles ("**GBP**"), the Social Bond Principles ("**SBP**") or the Sustainability Bond Guidelines ("**SBG**"). The Notes will be issued in series (each, a "**Series**") and each Series may be issued in one or more tranches (each, a "**Tranche**"). The terms of each Series will be set forth in the relevant Final Terms prepared in relation thereto in accordance with the provisions of this Base Prospectus. This Base Prospectus constitutes a base prospectus for the purposes of Article 5.4 of the Prospectus Directive.

**An investment in Notes issued under this Programme involves certain risks. For a discussion of certain risks and other factors that should be considered in connection with an investment in the Notes, see the section entitled "Risk Factors" of this Base Prospectus.**

Notice of the aggregate nominal amount of Notes, interest (if any) payable in respect of Notes, the issue price of Notes and certain other information which is applicable to each Tranche of Notes will be set out in a final terms document (the "**Final Terms**") which will be filed with the CSSF. Copies of Final Terms in relation to Notes to be listed on the Luxembourg Stock Exchange will also be published on the website of the Luxembourg Stock Exchange ([www.bourse.lu](http://www.bourse.lu)).

The Notes will be held in dematerialised form on behalf of the beneficial owners, until redemption or cancellation thereof, by Monte Titoli S.p.A. with registered office and principal place of business at Piazza degli Affari 6, 20123 Milan, Italy ("**Monte Titoli**"), for the account of the relevant Monte Titoli Account Holders. The expression "Monte Titoli Account Holders" means any authorised financial intermediary institution entitled to hold accounts on behalf of their customers with Monte Titoli and includes any depository banks appointed by Euroclear Bank S.A./N.V. as operator of the Euroclear System ("**Euroclear**") and Clearstream Banking, société anonyme, Luxembourg ("**Clearstream, Luxembourg**"). The Notes have been accepted for clearance by Monte Titoli. The Notes will at all times be held in book entry form and title to the Notes will be evidenced by book entries pursuant to the relevant provisions of Italian Legislative Decree dated 24 February 1998, No. 58, as subsequently amended and supplemented ("**Legislative Decree No. 58**") and in accordance with CONSOB and Bank of Italy Joint Regulation dated 13 August 2018, as subsequently amended and supplemented ("**CONSOB and Bank of Italy Regulation**"). The Noteholders may not require physical delivery of the Notes. However, the Noteholders may ask the relevant intermediaries for certification pursuant to Article 83-*quinquies* and 83-*sexies* of Legislative Decree No. 58.

The Programme is, as of the date of this Base Prospectus, rated BBB by Fitch Ratings Ltd. ("**Fitch Ratings**"), Baa3 by Moody's Investors Service Ltd. ("**Moody's**"), BBB by S&P Global Ratings Europe Ltd ("**S&P**") and BBB+ by Scope Ratings GmbH ("**Scope**"). Each of Fitch Ratings, Moody's, S&P and Scope is established in the EEA and registered under Regulation (EC) No. 1060/2009, as amended (the "**CRA Regulation**"), and is included in the list of registered credit rating agencies published on the website of the European Securities and Markets Authority at <http://www.esma.europa.eu/page/List-registered-and-certified-CRAs>. Notes issued under the Programme may be rated by any one or more of the rating agencies referred to above, or unrated. Where an issue of Notes is rated, its rating will not necessarily be the same as the rating applicable to the Programme or the rating(s) assigned to Notes previously issued. Whether or not each credit rating applied for in relation to the relevant Tranche of Notes will be (1) issued by a credit rating agency established in the EEA and registered under the CRA Regulation, or (2) issued by a credit rating agency which is not established in the EEA but will be endorsed by a CRA which is established in the EEA and registered under the CRA Regulation, or (3) issued by a credit rating agency which is not established in the EEA but which is certified under the CRA Regulation, will be disclosed in the Final Terms. In general, European regulated investors are restricted from using a rating for regulatory purposes if such rating is not issued by a credit rating agency established in the EEA and registered under the

CRA Regulation unless (1) the rating is provided by a credit rating agency not established in the EEA but endorsed by a credit rating agency established in the EEA and registered under the CRA Regulation or (2) the rating is provided by a credit rating agency not established in the EEA which is certified under the CRA Regulation.

**A rating is not a recommendation to buy, sell or hold securities and may be subject to suspension, change or withdrawal at any time by the assigning rating agency.**

**Joint Arrangers**

**Cassa depositi e prestiti S.p.A.**

**Barclays**

**Dealers**

**Banca IMI  
BNP PARIBAS  
Citigroup  
Crédit Agricole CIB  
Deutsche Bank  
J.P. Morgan  
Morgan Stanley  
Nomura  
UBS Investment Bank**

**Barclays  
BofA Merrill Lynch  
Commerzbank  
Credit Suisse  
HSBC  
Mediobanca  
MPS Capital Services  
Société Générale Corporate & Investment Banking  
UniCredit Bank**

## TABLE OF CONTENTS

|   |            |
|---|------------|
| <b>IMPORTANT NOTICES .....</b>                                    | <b>4</b>   |
| <b>RISK FACTORS .....</b>   | <b>10</b>  |
| <b>GENERAL DESCRIPTION OF THE PROGRAMME .....</b>                 | <b>32</b>  |
| <b>DOCUMENTS INCORPORATED BY REFERENCE .....</b>                  | <b>39</b>  |
| <b>SUPPLEMENT TO THE BASE PROSPECTUS .....</b>                    | <b>42</b>  |
| <b>TERMS AND CONDITIONS OF THE NOTES .....</b>                    | <b>43</b>  |
| <b>DESCRIPTION OF CASSA DEPOSITI E PRESTITI S.P.A.....</b>        | <b>91</b>  |
| <b>SELECTED FINANCIAL INFORMATION RELATING TO CDP .....</b>       | <b>147</b> |
| <b>SELECTED FINANCIAL INFORMATION RELATING TO CDP GROUP .....</b> | <b>149</b> |
| <b>TAXATION.....</b>  | <b>151</b> |
| <b>SUBSCRIPTION AND SALE.....</b>                                 | <b>163</b> |
| <b>GENERAL INFORMATION .....</b>                                  | <b>169</b> |

## IMPORTANT NOTICES

### ***Responsibility for this Base Prospectus***

The Issuer accepts responsibility for the information contained in this Base Prospectus and the Final Terms for each Tranche of Notes issued under the Programme. To the best of the knowledge of the Issuer, having taken all reasonable care to ensure that such is the case, the information contained in this Base Prospectus is in accordance with the facts and contains no omission likely to affect its import.

### ***Final Terms***

Each Tranche (as defined herein) of Notes will be issued on the terms set out herein under "*Terms and Conditions of the Notes*" as completed by the Final Terms.

### ***Important – EEA Retail Investors***

If the Final Terms in respect of any Notes includes a legend entitled "Prohibition of Sales to EEA Retail Investors", the Notes are not intended to be offered, sold or otherwise made available to, and should not be offered, sold or otherwise made available to any retail investor in the European Economic Area ("**EEA**"). For these purposes, a retail investor means a person who is one (or more) of: (i) a retail client as defined in point (11) of Article 4(1) of Directive 2014/65/EU (as amended, "**MiFID II**"); or (ii) a customer within the meaning of Directive 2002/92/EC (as amended or superseded), where that customer would not qualify as a professional client as defined in point (10) of Article 4(1) of MiFID II. Consequently, no key information document required by Regulation (EU) No 1286/2014 (the **PRiIPs Regulation**) for offering or selling the Notes or otherwise making them available to retail investors in the EEA has been prepared and therefore offering or selling the Notes or otherwise making them available to any retail investor in the EEA may be unlawful under the PRiIPs Regulation.

### ***MiFID Product Governance / Target Market***

The Final Terms in respect of any Notes will include a legend entitled "MiFID II Product Governance" which will outline the target market assessment in respect of the Notes and which channels for distribution of the Notes are appropriate. Any person subsequently offering, selling or recommending such Notes (a "**distributor**") should take into consideration the target market assessment; however, a distributor subject to MiFID II is responsible for undertaking its own target market assessment in respect of the Notes (by either adopting or refining the target market assessment) and determining appropriate distribution channels. A determination will be made at the time of issue about whether, for the purpose of the product governance rules under EU Delegated Directive 2017/593 (the "**MiFID Product Governance Rules**"), any Dealer subscribing for a Tranche of Notes is a manufacturer in respect of that Tranche, but otherwise neither the Joint Arrangers nor the Dealers nor any of their respective affiliates will be a manufacturer for the purpose of the MiFID Product Governance Rules.

### ***Other relevant information***

This Base Prospectus must be read and construed together with any supplements hereto and with any documents incorporated by reference herein (see "*Documents Incorporated by Reference*" below) on the basis that such documents are incorporated by reference in and form part of this Base Prospectus, and, in relation to any Tranche of Notes, should be read and construed together with the relevant Final Terms (as defined herein).

Neither this Base Prospectus nor any other information supplied in connection with the Programme or any Notes (a) is intended to provide the basis of any credit or other evaluation or (b) should be considered as a recommendation by the Issuer or any of the Dealers that any recipient of this Base Prospectus or any other information supplied in connection with the Programme or any Notes should purchase any Notes. Each Investor contemplating purchasing any Notes should make its own independent investigation of the financial condition and affairs, and its own appraisal of the creditworthiness, of the Issuer. Neither this Base Prospectus nor any other information supplied in connection with the Programme or the issue of any Notes constitutes an offer or invitation by or on behalf of the Issuer, any of the Dealers to any person to subscribe for or to purchase any Notes.

The Issuer has confirmed to the Dealers named under "*Subscription and Sale*" below that this Base Prospectus (including for this purpose, each relevant Final Terms) contains all information which is (in the context of the Programme, the issue, offering and sale of the Notes) material; that such information is true and accurate in all material respects and is not misleading in any material respect; that any opinions, predictions or intentions expressed herein are honestly held or made and are not misleading in any material respect; that this Base Prospectus does not omit to state any material fact necessary to make such information, opinions, predictions or intentions (in the context of the Programme, the issue, offering and sale of the Notes) and is not misleading in any material respect; and that all proper enquiries have been made to verify the foregoing.

### ***Legality of purchase***

Neither the Issuer, the Dealers, nor any of their respective affiliates has or assumes responsibility for the lawfulness of the acquisition of the Notes by a prospective investor in the Notes, whether under the laws of the jurisdiction of its incorporation or the jurisdiction in which it operates (if different), or for compliance by that prospective investor with any law, regulation or regulatory policy applicable to it.

### ***Unauthorised information***

No person has been authorised to give any information or to make any representation not contained in or not consistent with this Base Prospectus or any other document entered into in relation to the Programme or any information supplied by the Issuer or such other information as is in the public domain and, if given or made, such information or representation should not be relied upon as having been authorised by the Issuer or any Dealer.

Neither the Dealers nor any of their respective affiliates have authorised the whole or any part of this Base Prospectus and none of them makes any representation or

warranty or accepts any responsibility as to the accuracy or completeness of the information contained in this Base Prospectus. Neither the delivery of this Base Prospectus or any Final Terms nor the offering, sale or delivery of any Note shall, in any circumstances, create any implication that the information contained in this Base Prospectus is true subsequent to the date hereof or the date upon which this Base Prospectus has been most recently supplemented or that there has been no adverse change, or any event reasonably likely to involve any adverse change, in the prospects or financial or trading position of the Issuer since the date thereof or, if later, the date upon which this Base Prospectus has been most recently amended or supplemented or that any other information supplied in connection with the Programme is correct at any time subsequent to the date on which it is supplied or, if different, the date indicated in the document containing the same.

### ***Restrictions on distribution***

This Base Prospectus does not constitute an offer to sell or the solicitation of an offer to buy any Notes in any jurisdiction to any person to whom it is unlawful to make the offer or solicitation in such jurisdiction. The distribution of this Base Prospectus and any Final Terms and the offering, sale and delivery of the Notes in certain jurisdictions may be restricted by law. The Issuer and the Dealers do not represent that this Base Prospectus may be lawfully distributed, or that any Notes may be lawfully offered, in compliance with any applicable registration or other requirements in any such jurisdiction, or pursuant to an exemption available thereunder, or assume any responsibility for facilitating any such distribution or offering. In particular, no action has been taken by the Issuer or the Dealers which is intended to permit a public offering of any Notes or distribution of this Base Prospectus in any jurisdiction where action for that purpose is required. Accordingly, no Notes may be offered or sold, directly or indirectly, and neither this Base Prospectus nor any advertisement or other offering material may be distributed or published in any jurisdiction, except under circumstances that will result in compliance with any applicable laws and regulations. Persons into whose possession this Base Prospectus or any Final Terms comes are required by the Issuer and the Dealers to inform themselves about and to observe any such restrictions. For a description of certain restrictions on offers, sales and deliveries of Notes and on the distribution of this Base Prospectus or any Final Terms and other offering material relating to the Notes, see "Subscription and Sale".

The Notes have not been and will not be registered under the United States Securities Act of 1933, as amended (the "**Securities Act**"), and may not be offered or sold within the United States or to, or for the account or benefit of, U.S. persons except in certain transactions exempt from the registration requirements of the Securities Act. Terms used in this paragraph have the meanings given to them by Regulation S under the Securities Act.

Neither this Base Prospectus or any supplement thereto nor any Final Terms (or any part thereof) constitutes an offer or an invitation to subscribe for or purchase any Notes and should not be considered as a recommendation by the Issuer, the Dealers or any of them that any recipient of this Base Prospectus or any Final Terms should subscribe for or purchase any Notes. Each recipient of this Base Prospectus or any Final Terms shall be taken to have made its own investigation and appraisal of the condition (financial or otherwise) of the Issuer.

### ***Suitability of the Notes as an investment***

The Notes may not be a suitable investment for all investors. Each potential Investor in the Notes must determine the suitability of that investment in light of its own circumstances. In particular, each potential investor may wish to consider, either on its own or with the help of its financial and other professional advisers, whether it:

- (i) has sufficient knowledge and experience to make a meaningful evaluation of the Notes, the merits and risks of investing in the Notes and the information contained or incorporated by reference in this Base Prospectus or any applicable supplement;
- (ii) has access to, and knowledge of, appropriate analytical tools to evaluate, in the context of its particular financial situation, an investment in the Notes and the impact the Notes will have on its overall investment portfolio;
- (iii) has sufficient financial resources and liquidity to bear all of the risks of an investment in the Notes, including Notes where the currency for principal or interest payments is different from the potential investor's currency;
- (iv) understands thoroughly the terms of the Notes and is familiar with the behaviour of financial markets; and
- (v) is able to evaluate possible scenarios for economic, interest rate and other factors that may affect its investment and its ability to bear the applicable risks.

Legal investment considerations may restrict certain investments. The investment activities of certain investors are subject to legal investment laws and regulations, or review or regulation by certain authorities. Each potential investor should consult its legal advisers to determine whether and to what extent (1) Notes are legal investments for it, (2) Notes can be used as collateral for various types of borrowing, and (3) other restrictions apply to its purchase or pledge of any Notes. Financial institutions should consult their legal advisers or the appropriate regulators to determine the appropriate treatment of Notes under any applicable risk-based capital or similar rules.

### ***Programme limit***

The maximum aggregate principal amount of Notes outstanding at any one time under the Programme will not exceed Euro 10,000,000,000 (and for this purpose, any Notes denominated in another currency shall be converted into Euro at the date of the agreement to issue such Notes in accordance with the provisions of the Dealer Agreement). The maximum aggregate principal amount of Notes which may be outstanding at any one time under the Programme may be increased from time to time, subject to compliance with the relevant provisions of the Dealer Agreement, as defined under "Subscription and Sale". In the event of increase of the original maximum amount of the Programme as set out herein, the Issuer shall prepare a supplement to the Base Prospectus.

## ***Presentation of information***

Unless otherwise indicated, the financial information in this Base Prospectus relating to the Issuer has been derived from (i) the audited non-consolidated annual financial statements of the Issuer for the financial years ended 31 December 2018 and 31 December 2017 and (ii) the audited consolidated annual financial statements of the Issuer for the financial years ended 31 December 2018 and 31 December 2017 (together, the "**Financial Statements**").

The Issuer's financial year ends on 31 December, and references in this Base Prospectus to any specific year are to the 12-month period ended on 31 December of such year. The Financial Statements have been prepared in accordance with the International Financial Reporting Standards (IFRSs) issued by the International Accounting Standards Board (IASB), including the SIC and IFRIC interpretations, endorsed by the European Union, as provided by Regulation (EC) No. 1606 of 19 July 2002, published in the Official Journal of the European Union L. 243 on 11 September 2002.

Capitalised terms which are used but not defined in any particular section of this Base Prospectus will have the meaning attributed to them in "*Terms and Conditions of the Notes*" or any other section of this Base Prospectus. In addition, the following terms as used in this Base Prospectus have the meanings defined below.

In this Base Prospectus, unless otherwise specified, references to a "**Member State**" are to a Member State of the European Economic Area, references to "**Euro**" "**EUR**" or "**€**" are to the single currency introduced at the start of the third stage of the European Economic and Monetary Union pursuant to the Treaty establishing the European Community, as amended, and references to "**£**" or "**Sterling**" are to the currency of the United Kingdom.

References to a **billion** are to a thousand million.

Certain figures included in this Base Prospectus have been subject to rounding adjustments; accordingly, figures shown for the same category presented in different tables may vary slightly and figures shown as totals in certain tables may not be an arithmetic aggregation of the figures which precede them.

## ***Alternative Performance Measures***

This Base Prospectus does not contain any financial measure that is not recognised as a measure of performance under IFRS or Italian GAAP, otherwise known as "**Alternative Performance Measures**".

## ***Stabilisation***

**In connection with the issue of any Tranche of Notes, the Dealer or Dealers (if any) named as the Stabilising Manager(s) (or persons acting on behalf of any Stabilising Manager(s)) in the applicable Final Terms may over allot Notes or effect transactions with a view to supporting the market price of the Notes at a level higher than that which might otherwise prevail. However, stabilisation may not necessarily occur. Any stabilisation action may begin on or after the date on which adequate public disclosure of the terms of the offer of the**



**relevant Tranche of Notes is made and, if begun, may cease at any time, but it must end no later than the earlier of 30 days after the issue date of the relevant Tranche of Notes and 60 days after the date of the allotment of the relevant Tranche of Notes. Any stabilisation action or over-allotment must be conducted by the relevant Stabilising Manager(s) (or person(s) acting on behalf of any Stabilising Manager(s)) in accordance with all applicable laws and rules.**

## RISK FACTORS

*The following are the risk factors relating to the Issuer and Notes to be issued under the Programme which prospective purchasers of Notes should consider prior to making an investment decision. Prospective purchasers of Notes should also read the information set out elsewhere in this Base Prospectus. Words and expressions defined in the "Terms and Conditions of the Notes" (the "**Conditions**") below or elsewhere in this Base Prospectus have the same meanings in this section.*

*In purchasing Notes, investors assume the risk that the Issuer may be unable to make all payments due in respect of the Notes. There are a wide range of factors which, individually or together, could result in the Issuer becoming unable to make all payments due. It is not possible to identify all such factors or to determine which factors are most likely to occur, as the Issuer may not be aware of all relevant factors, and certain factors which it currently deem not to be material may become material as a result of the occurrence of events outside the Issuer's control. The Issuer has identified in this Base Prospectus a number of factors that could materially adversely affect its businesses and ability to make payments due.*

*In addition, factors which are material for the purpose of assessing the market risks associated with Notes issued under the Programme are also described below.*

*Prospective investors should also read the detailed information set out elsewhere in this Base Prospectus and reach their own views prior to making any investment decision.*

### **Risk factors relating to the Issuer**

#### ***Issuer's ability to meet its obligations under the Notes***

No security interest has been created by CDP for the benefit of the holders of the Notes for their claims under the Notes, nor will any guarantee be issued by the Republic of Italy in favour of the Noteholders. Consequently, the Issuer will meet its payment obligations under the Notes primarily through the result of its business activities. Any adverse effect on CDP's business activities or its ability to generate sufficient revenues may have a material adverse effect on CDP's financial condition and consequently on its ability to meet its payment obligations under the Notes.

Noteholders will have access to all assets of CDP to satisfy their claims under the Notes, other than assets (if any) segregated by CDP in favour of certain creditors of CDP, pursuant to paragraph 18 of Article 5 of Italian Law Decree No. 269 of 30 September 2003 ("**Article 5**"). See further details on segregated asset under "*Segregated Assets of CDP*" below.

#### ***Segregated Assets of CDP***

CDP may segregate any of its assets, in whole or in part, in favour of the holders of asset-backed securities issued thereby or in favour of other lenders of CDP. In particular, pursuant to paragraph 18 of Article 5, upon segregation, the assets may be attached only by the holders of the asset-backed securities or other lenders identified by CDP and constitute separate assets in all respects from that of CDP until final discharge of their rights against CDP. In addition, notwithstanding the

provisions of article 2447-*bis*, letter (a) of the Italian Civil Code on the segregation of assets by joint stock companies to specific businesses, the segregation of assets upon which CDP may resolve, is not subject to any limit sets by law. Accordingly, Noteholders will not have recourse to any assets of CDP that are segregated by law to satisfy amounts due to them under the Notes.

### ***Existing Indebtedness***

As of 31 December 2018, the total gross financial debt of the Issuer amounted to Euro 342,595<sup>1</sup> million, of which Euro 258,040 million was represented by passbook savings accounts and postal savings bonds issued by the Issuer. The obligations of the Issuer in respect of such accounts and bonds are guaranteed by the Republic of Italy. In the event of enforcement of the guarantee, pursuant to the provisions of the decree of the Ministry of Economy and Finance (the "**MEF**") of 6 October 2004, the Republic of Italy has conditioned its repayment rights against CDP to the absence of any prejudice to (i) the claims of public bodies or entities arising from the Separate Account System (as defined below), (ii) the continuance of CDP's corporate activities carried out pursuant to paragraph 7, letter (a) of Article 5; and (iii) its title to the shareholdings transferred to CDP by the MEF at the time of its transformation in a joint stock company.

### ***Limited rights of individual Noteholders***

The protection and exercise of the Noteholders' rights against the Issuer is one of the duties of the Representative of the Noteholders. The Conditions limit the ability of individual Noteholders to commence proceedings against the Issuer by conditioning the ability of any Noteholder to commence any such individual actions to the prior approval of a Meeting of all Series of Noteholders and failure by the Representative of the Noteholders to take such actions within a reasonable period of time.

### **Risk factors relating to the financial crisis and the macroeconomic environment**

CDP and its subsidiaries (the "**CDP Group**") carry out their business activities mainly in Italy with public entities and, to a lesser extent, private entities, including banking groups operating in Italy. As such, the CDP Group's business is affected by the economic conditions affecting Italy, which, at the same time, are connected to European and global economic conditions.

The current international macroeconomic environment, and in particular the macroeconomic environment in Europe, is still characterised by significant uncertainty relating to: (i) economic trends relating to recovery expectations and consolidation of the growth dynamics of the economies of countries such as the United States and China, which have been subject to substantial growth also in recent years, (ii) future developments in the monetary policy of the European Central Bank ("**ECB**") in the Eurozone and of the Federal Reserve in the dollar-zone, as well as the policies implemented by the various countries to encourage competitive

---

<sup>1</sup> The gross financial debt is only referred to the funding and is the sum of the items 10, 20, 30 and 50 of the balance sheet - liabilities and equity, net of accrued expenses, deferred income, fair value adjustments and other liabilities (Euro 495 million)

devaluation of their currency, (iii) the sustainability of sovereign debt of some countries and related tensions that are more or less recurring on financial markets, and (iv) recent developments in connection with the referendum held in 2016 in the United Kingdom following which the United Kingdom invoked, on 29 March 2017, article 50 of the Lisbon treaty and officially notified the European Union of its decision to withdraw from the European Union (so called "Brexit").

### ***The sovereign debt crisis***

The sovereign debt crisis has raised concerns about the long-term sustainability of the European Monetary Union and the ordinary activity of many commercial and investment banks as well as insurance companies, some of which have become insolvent or have been forced to merge with other financial firms or have requested assistance from governments, central banks and international monetary funds which have intervened injecting liquidity into the economic system, also taking part in the restructuring of some financial entities. Moreover, other negative factors, such as increasing unemployment levels, have worsened the situation.

Persistent market tensions might negatively affect the funding costs and economic outlook of some euro member countries, including Italy. This, together with the risk that some countries (even if not very significant in terms of gross domestic product) might leave the euro area, would have a material and negative impact on Italy's sovereign debt and economic conditions and, therefore, on CDP and its operations.

Any deterioration of the Italian economy would have a material adverse effect on CDP, in light of the CDP Group's significant exposure to the Italian economy. Since the beginning of the sovereign debt crisis in May 2010, credit quality has generally declined, as reflected by downgrades suffered by several countries in the Eurozone, including Italy. The Issuer's credit ratings closely reflect the rating of the Republic of Italy and are therefore exposed to the risk of decline in the sovereign credit rating of Italy. Accordingly, on the basis of the methodologies used by rating agencies, further downgrades of Italy's credit rating may have a knock-on effect on the credit rating of Italian issuers, such as CDP.

Despite the several initiatives of supranational organisations to deal with the heightened sovereign debt crisis in the euro area, global markets remain characterised by high volatility. Any further acceleration of the European sovereign debt crisis could likely significantly affect, among other things, the recoverability and quality of the sovereign debt securities held by CDP.

### ***Risks relating to CDP's relationship with the Republic of Italy***

The nature of CDP's business, as lender of funding to Italian public entities, thereby providing a service of general economic interest, implies that, in addition to the risks connected with the need for renewal upon expiry of agreements and concessions, CDP bears the risks associated with its special relationship with the Italian government, which is CDP's main shareholder, and therefore may exercise a significant influence on CDP's operations, which could be substantial in the case of protracted political uncertainty.

In this regard, it should also be noted that: (i) any downgrade in public ratings assigned to the Republic of Italy normally involve corresponding changes in CDP's

public ratings and those events can have a potential indirect impact on CDP's funding conditions; (ii) CDP holds a significant investment Italian government securities, therefore any deterioration in the spread of the Italian government bonds compared to other European government bonds could have a significant impact on the value of these assets.

## **Risk factors relating to market conditions affecting CDP**

### ***Credit Risk***

The CDP Group is subject to credit risk which consists of the risk arising out of the possible default of one or more debtors with respect to their obligations towards CDP. The business activity carried out by the CDP Group, and in particular by the CDP Group parent company, consists of, *inter alia*, granting loans to Italian public entities, local entities and companies (including the main banking groups operating in Italy), hedging activities through derivatives, treasury activities in the context of both the separate account system ("**Separate Account System**") and ordinary account system ("**Ordinary Account System**"). CDP is therefore subject to the risk that its counterparties do not fulfil their own obligations when payments are due, as well as to the risk arising out of loans granted upon the basis of incomplete, false and untruthful information.

### ***Market risks***

Market risks mean the risks of losses arising from adverse fluctuations of the value of assets (or financial exposures), including securities, which may decrease (or increase) following the fluctuations of some market conditions. Such risk may arise from the fluctuations of interest rates, credit spread, exchange rates, shares prices or any other fluctuating parameter, such as market volatility and the implied probabilities of default of the various financial assets.

The market risk to which CDP is subject concerns both financial instruments, including derivatives, and financial exposures which are influenced by credit spread and interest rates during different observation periods. Market risk includes, *inter alia*, the following risks:

- risks connected with interest rates fluctuations;
- risk relating to price fluctuations; and
- risks connected with exchange rates.

### ***Risks connected with interest rate fluctuations***

The risk arising out of the fluctuation of interest rates consists in the risk that the value and yield of assets and liabilities would vary following market fluctuations of interest rates.

In the context of its business activity, CDP is subject to interest rate risk in different ways, in particular through repricing, term structure, basis and optionality. Moreover, CDP carries out collection of savings and lending activities. The value and yield both of the credits arising out of loans granted by CDP and the exposures connected with

the collection of savings carried out by CDP are subject to interest rates fluctuations which, as such, are influenced by various parameters not under the Issuer's control, such as monetary policies, macroeconomic and political conditions. In particular, fluctuations of interest rates may increase costs related to lending activities carried out by CDP faster and more substantially than yields on assets, for example because of a mismatch between maturities, or given a maturity between interest rate sensitivities, of assets and liabilities.

At the same time, decreasing interest rates may cause a minor yield arising from the assets held by CDP which may not match a similar decrease in the cost of funding. Such situations, as well as the current scenario, characterised by very low interest rates, may affect the value of CDP's assets and exposures. This is mainly due to the fact that CDP invests its liquidity mainly in an account held with the central Treasury of the Italian State indexed to current government bonds yields. Therefore, and if such yields decrease, CDP might not be able to reduce the costs related to the collection of savings accordingly.

In particular, the risk to which CDP is subject regarding interest rates is not properly comparable to the one in the banking sector, due to the early redemption option in favour of the holders of postal savings bonds which represent the main sources of long-term collection of savings used by CDP. The value of the put option and the bondholder's incentive to exercise the option is strongly influenced by interest rate levels and trends.

Therefore, the increase and decrease in interest rates may adversely affect the financial situation and operating results of CDP and, therefore, the Issuer's ability to fulfil its obligations under the Notes.

In addition, with respect to the issue of postal savings bonds indexed to consumer prices in Italy, CDP is also subject to inflation risk. In particular, such risk is due to the fact that as a consequence of the increasing inflation rate, CDP shall pay a greater amount of interest to bondholders. Therefore, a rise in inflation rate in Italy may adversely affect the financial situation and the operating results of CDP and, therefore, the ability of the Issuer to fulfil its obligations under the Notes. CDP safeguards the inflation risk using methodologies equivalent to those adopted in the banking sector for monitoring interest rates risks.

CDP monitors its exposure and the interest rate risk to which is subject through an evaluation of the response of its financial statements data to interest rate fluctuations, quantified by means of a "sensitivity" analysis (for less severe turbulence) or "stress test" (for more severe turbulence). However, even though the Issuer has implemented an interest rate risk monitoring structure, there is no guarantee that such structure would be effective and suitable for containing such risk for CDP. Such situation may adversely affect the financial situation and the operating results of CDP and, therefore, the ability of the Issuer to fulfil its obligations under the Notes.

### ***Risks relating to price fluctuations***

Price risk consists in the risk relating to price fluctuations of equity securities, equity-linked bonds, undertaking for collective investments and, index-linked, derivatives.

The CDP Group holds interests in Italian corporations and investment funds and, therefore, it is subject to the risk that the value of such interests may be affected by fluctuations of the relevant shares' or units' value as well as by fluctuations of the relevant derivatives' value.

A reduction of the value of such investments may adversely affect the financial situation and the operating results of CDP and, therefore, the ability of the Issuer to fulfil its obligations under the Notes.

In addition, CDP is subject to the risks arising out of its direct and indirect shareholdings (in listed and non-listed companies) and from the units held in investment funds. Among the interests held by CDP, there are those in ENI S.p.A. ("**ENI**"), SACE S.p.A. ("**SACE**"), CDP RETI S.p.A. ("**CDP RETI**"), CDP Equity S.p.A. ("**CDP Equity**"), Fintecna S.p.A. ("**Fintecna**"), Poste Italiane S.p.A. ("**Poste**"), Fincantieri S.p.A. ("**Fincantieri**"), and Saipem S.p.A. ("**Saipem**").

### ***Risks connected with exchange rates***

Exchange rate risk is the risk that changes in exchange rates might have a negative impact on the net income or economic value of CDP.

Certain activities of CDP can generate exchange rate risk. CDP undertakes such activities only if covered by appropriate exchange rate hedges.

The activities of CDP that can engender such exposure are normally associated with the issue of bonds denominated in foreign currencies, equity investments the value of which can be exposed to changes in exchange rates, the purchase of bonds denominated in foreign currencies and the granting of loans denominated in currencies other than the Euro under the "export bank" system.

### ***Liquidity risk***

The liquidity risk consists in the risk arising out of the lack of funds needed in the ordinary course of business and, as consequence thereof, in the risk arising out of the inability to fulfil, without any exorbitant costs, payment obligations when due.

For CDP, liquidity risk arises with respect to both its ability to collect funds on the market ("funding liquidity risk"), in connection with passbook savings accounts and postal savings bonds representing the main exposures in the Separate Account System, and its difficulty to liquidate its own assets ("asset liquidity risk").

In order to face issues related to the need of liquidity in the context of the Ordinary Account System, CDP raises funds on capital markets or avails itself of loans granted by the European Investment Bank ("**EIB**") at conditions substantially equivalent to those available to banks. CDP has adopted procedures to avoid the rising of unexpected needs of liquidity by timely prediction of demand of supply, by setting limits to the mismatching of the maturities between asset and liabilities, by monitoring its short-term liquidity and its liquidity requirements in the short, medium and long-term period. Moreover, among the procedures adopted to face liquidity risk, CDP has implemented a system called "Contingency Funding Plan", which describes the processes and the strategies for managing a possible liquidity crisis.

However, there is no guarantee that the procedures adopted in order to avoid liquidity risk are effective and sufficient to mitigate such risk for CDP. Therefore, the inefficacy of such procedures may adversely affect the financial situation and operating results of CDP and, as a consequence thereof, affect the Issuer's ability to fulfil its obligations under the Notes.

### ***Risks relating to the potential asset-liability mismatch***

In the context of its business CDP, is subject to potential asset-liability mismatch mainly due to different characteristics, in terms of liquidity and interest rate indexation, between lending activity, which represents most of the asset side, and postal saving collecting, which represents the greatest component of the funding side. For further information please see the paragraphs "*Risks connected with interest rate fluctuations*" and "*Liquidity risk*" above.

### **Risk factors relating to funding**

CDP is subject to the risk arising out of the concentration of the sources for the collection of savings. In particular, postal savings are the main source of collection for CDP.

As at 31 December 2018, the total stock of postal savings, including passbook savings accounts and postal savings bonds pertaining to CDP, came to Euro 258,040 million, compared to Euro 252,754 million as at 31 December 2017.

More specifically, the carrying amount of passbook savings accounts was to Euro 105,774 million, while postal savings bonds, which are measured at amortised cost, was to Euro 152,266 million.

Passbook savings accounts (*libretti di risparmio postale*) are financial products, issued by CDP and placed by Poste, represented by registered deposits, redeemable at demand, assisted by the State guarantee. Postal savings bonds (*buoni fruttiferi postali*) are registered financial products, issued by CDP and placed by Poste, with a maturity up to 20 years, redeemable on demand, assisted by the State guarantee.

Postal savings products (i.e. postal savings bonds and passbook savings accounts) are placed exclusively by Poste.

On 14 December 2017, CDP and Poste entered into a new agreement for the placement of postal saving products (the "**Agreement**"). The Agreement has a duration of three years and shall be effective for the period from 2018 to 2020.

Any possible variation of the corporate governance of Poste, without any variation of the majority, shall not affect the Agreement and the placement activities carried out by Poste with respect to the postal saving products.

In light of the above, the Agreement enhances a risk of concentration of CDP funding sources. In any event, the Agreement shall assure the stabilisation of the funding volumes and the management of extraordinary situations such as those regarding the variation of the corporate governance of the parties, even on the basis of the recent amendments introduced by Italian Law 23 December 2014, No. 190.



In order to mitigate the risk of concentration of the funding sources, some measures have been considered to improve efficiency, consolidation and differentiation of funding for CDP, which should provide continuous and stable funding volumes. In particular, the sources of institutional funding have been enhanced with the establishment of the Programme, the launch of a commercial paper programme, the negotiation of new lines of credit granted by the EIB and other supranational institutions and the establishment of a new program of retail bonds. However, there is no guarantee that the measures implemented in order to avoid funding concentration risk are effective and sufficient to mitigate such risk for CDP. Therefore, the inefficacy of such measures may adversely affect financial situation and operating results of CDP and, as consequence thereof, affect the Issuer's ability to fulfil its obligations under the Notes.

### **Risks relating to CDP initiatives in support of Italian banking system stability**

The persistence of the crisis in the financial markets and the slowdown in the global economy required the implementation of certain measures aimed at supporting the stability of the Italian banking system. Such measures may expose the Issuer, in particular in the event of a crisis in the banking system, to the negative performance of its investments, such as for example in the case of recapitalisation transactions, guarantees, or purchase of non-performing loans.

In particular, CDP has, together with the most important Italian banks and insurance companies, joined the Atlante Funds (as defined below) and it is therefore subject to the risk arising out of its exposure to these funds.

Incorporated in April 2016, the Atlante Fund, a closed-end alternative investment fund established under Italian law named "Atlante" (the "Atlante Fund"), was promoted and managed by Quaestio Capital SGR S.p.A. ("Quaestio Capital"). The Atlante Fund's main objectives are (i) to facilitate the disposal of non-performing loans of Italian banks and (ii) to support the recapitalisation of Italian banks, by acting as guarantor (back stop facility). On 8 August 2016, a closed-end alternative investment fund established under Italian law called "Italian Recovery Fund", formerly Atlante II Fund (the "Italian Recovery Fund" and, together with the Atlante Fund, the "Atlante Funds") and promoted by Quaestio Capital was established.

More specifically, the Atlante Funds may act:

- (i) as underwriter in the recapitalisation of Italian banks whose capital requirements have fallen below the minimum thresholds required by the Supervisory Review and Evaluation Process ("**SREP**"); and
- (ii) in the context of securitisations of non-performing loans, by purchasing junior note tranches (that are subject to a greater higher risk).

Together with the largest Italian banking and insurance entities, CDP (i) invested in the Atlante Fund, pledging a maximum commitment of Euro 500 million; and (ii) pledged a maximum commitment of Euro 320 million to the Atlante II Fund.

Since inception, the Atlante Fund participated in two transactions to recapitalise Italian banks – Banca Popolare di Vicenza S.p.A. and Veneto Banca S.p.A – and the Atlante II Fund invested in the non-performing loans of Nuova Banca Etruria e del

Lazio S.p.A., Nuova Cassa di Risparmio di Chieti S.p.A., Nuova Banca delle Marche S.p.A., Nuova Cassa di Risparmio di Ferrara S.p.A., Cassa di Risparmio di Rimini S.p.A., Cassa di Risparmio di San Miniato S.p.A., Cassa di Risparmio di Cesena S.p.A., and Banca Monte dei Paschi di Siena S.p.A.

The Atlante Funds are periodically valued on the basis of the assets contained in the relevant fund portfolio. Therefore, the value of the investments made by CDP in the Atlante Funds are accordingly exposed to fluctuations.

### **Operational Risk**

The CDP group is subject to operational risk (*i.e.* the risk of loss resulting from inadequate or failed internal processes, people and systems or from external events). Such risk includes – *inter alia* – the risk of losses resulting from internal or external fraud, human error, employment relationships and workplace safety, business disruption, system unavailability, breach of contract, process management, damage to company assets, malicious software/cyber attacks and natural disasters.

The operational risk includes the legal risk (*i.e.* the risk of loss resulting from the breach of law and regulations, contractual or non-contractual liability and further disputes. CDP has adopted the guidelines established by the Basel Committee for the banking industry as the benchmark for managing operational risk. However, there is no guarantee that the measures implemented in order to mitigate operational risk are effective and sufficient to mitigate such risk for CDP. Therefore, the inefficacy of such measures may adversely affect financial situation and operating results of CDP and, as consequence thereof, affect the Issuer's ability to fulfil its obligations under the Notes.

### **Risk factors arising out of shareholdings**

CDP holds shares in Italian companies and investment funds. The CDP Group is exposed to the risk that its net economic value, profitability or net equity could be adversely affected by variables relating to equities and shareholdings in the investment funds in which it is invested and, in particular, by the market price of such securities and shares and related derivatives, or by changes in the present and prospective profitability of the investment in such securities and shares and related derivatives, which depends, *inter alia*, on dividends from time to time approved by the relevant companies and investment funds in which CDP holds shares.

### **Risk factors arising out of companies subject to CDP control**

CDP Group is subject to the same risks to which certain companies forming part of the CDP Group are subject (such as SACE, Fintecna, Fincantieri, CDP Equity and CDP Immobiliare S.r.l. ("**CDP Immobiliare**") CDP Reti and its subsidiaries Terna S.p.A. ("**Terna**"), SNAM S.p.A. ("**SNAM**") and Italgas S.p.A. ("**Italgas**"). In particular, the members of the CDP Group are mainly subject to (i) market risk, (ii) liquidity risk and credit risk, (iii) operational risk and (iv) risks arising out of legal disputes (see also "*Description of Cassa depositi e prestiti S.p.A. – Legal Proceedings – Legal disputes relating to certain subsidiaries of CDP*").

## **SACE Group**

The group composed by SACE and its subsidiaries – SACE FCT S.p.A., SACE BT S.p.A. and SIMEST S.p.A. ("**SACE Group**") – is mainly subject to (i) insurance risk; (ii) financial risks and (iii) risks arising out of legal disputes (see also "*Description of Cassa depositi e prestiti S.p.A. – Legal Proceedings – Legal disputes relating to certain subsidiaries of CDP*").

SACE Group is mainly exposed to insurance risks – through SACE S.p.A. and SACE BT S.p.A. ("**SACE BT**") – which include technical risk, meant as underwriting and credit risk. The former, relating to the portfolio of guarantees, refers to the risk of losses arising from unfavourable claim performance compared with estimated claims (pricing risk), or from mismatches between the cost of claims and the amount reserved (reserve risk). The latter refers to the risk of default of the counterparties and of changes in their creditworthiness. Both risks are managed by the adoption of prudent pricing and reserve policies defined using best market practices, underwriting criteria, monitoring techniques and active portfolio management.

As at 31 December 2018, the total exposure of SACE, calculated as the sum of credit and guarantees issued (principal and interest) amounted to Euro 61 billion, an increase of 20.7 per cent. compared to the end of 2017. The pace of growth is mainly due to the guarantee portfolio, which accounted for 99.1 per cent. of the overall exposure. SACE BT is subject to short-term credit insurance risks, to surety business risks and to construction/other property damage business risks. As at 31 December 2018 the total exposure in the portfolio of SACE BT amounted to Euro 51.9 billion, an increase of 25.8 per cent. compared to the end of 2017.

SACE FCT S.p.A. ("**SACE FCT**"), the company engaged in trade receivables financing, is subject to financial risks arising from receivable financing aimed at suppliers of public sector companies, large industrial groups and export companies. Factoring receivables of SACE FCT, net of collected receivables and credit notes, as at 31 December 2018 amounted to Euro 1,5 million, and show a decrease of 20.9 per cent. compared to 31 December 2017.

Since 30 September 2016, SACE holds a 76.01 per cent. shareholding in SIMEST S.p.A. ("**SIMEST**"), with the remaining 24 per cent. being held by other private sector shareholders including banks and trade associations. SIMEST works alongside Italian companies and may acquire up to 49 per cent. of the share capital of foreign firms, both directly and through a venture capital fund, in order to provide assistance to Italian companies' ("**Partners**") that wish to invest in companies incorporated outside of the European Union. In addition, SIMEST may acquire shareholdings of up to 49 per cent. in Italian companies and/or their EU subsidiaries that develop investments in production and in innovation and research on market terms without financial assistance.

Upon acquisition of the investment, the Partners undertake to purchase SIMEST's interest at the end of the investment period (up to eight years). The commitment to repurchase is in some cases also covered by banking/insurance guarantees, collateral and/or corporate guarantees.

In the light of the above, SIMEST is ultimately exposed to the credit risk of the Partners.

As at 31 December 2018 the total shareholding portfolio of SIMEST amounted to Euro 601 million, an increase of 5 per cent. compared to the end of 2017, increasing resources dedicated to internalisation projects.

### ***Terna Group***

As a normal part of operations, Terna, the parent company of the Terna Group, and its subsidiaries (the "**Terna Group**") are exposed to a variety of financial risks: market risk (exchange rate risk, interest rate risk and inflation risk), liquidity risk and credit risk. Terna's risk management policies seek to identify and analyse the risks which the Terna Group is exposed to, establishing appropriate limits and controls and monitoring risks and compliance with such limits. These policies and the related systems are reviewed on a regular basis in order to consider any changes in market conditions or in the operations of the Terna Group. The exposure of the Terna Group to the aforementioned risks is substantially represented by the exposure of Terna, as parent company of the Terna Group. As a part of the financial risk management policies approved by its board of directors, Terna has established the responsibilities and operating procedures for financial risk management, specifically as it concerns the instruments to be used and the precise operating limits in managing them.

### ***SNAM Group***

SNAM, the parent company of the SNAM Group, established the Enterprise Risk Management ("**ERM**") unit, reporting directly to its Chief Executive Officer, in order to monitor the integrated corporate risk management process for all its subsidiaries (together with SNAM, the "**SNAM Group**"). ERM's main goals are defining a risk assessment model that enables the identification of the aforementioned risks based on common, cross-functional logic and the prioritisation of risks, as well as the consolidation of mitigation actions and the development of a reporting system.

The ERM method adopted by the SNAM Group for the structured, consistent identification, assessment, management and control of risks is in line with the reference frameworks and existing international best practice (COSO Framework and ISO 31000). ERM operates within the wider context of SNAM's risk management and internal control system.

Furthermore, in 2018 SNAM started a new integrated Risk Assurance and Compliance project, with the aim of defining and implementing an integrated risk assessment model that, through a single IT tool and a single database, rationalise and integrate the information flows of second-level controls with a synergistic approach aimed at maximum efficiency.

The main risks identified, monitored and managed by SNAM within the scope of corporate risks are: (i) market risk resulting from exposure to interest rates and natural gas price fluctuations; (ii) credit risk resulting from the possibility of default by a counterparty; (iii) liquidity risk resulting from the lack of financial resources to fulfil short-term commitments; (iv) rating risk; (v) default risk and debt covenants; (vi) operational risk and (vii) specific risks linked to the sectors in which the group operates.

## **Italgas Group**

The risk management and internal control model for corporate reporting adopted by Italgas was defined in line with the provisions of Italian law and is based, in terms of method, on the "CoSO Framework" ("Internal Control – Integrated Framework", issued by the Committee of Sponsoring Organizations of the Treadway Commission), international reference model for the establishment, updating, analysis and assessment of the internal control system.

The design, establishment and maintenance of the Corporate Reporting Internal Control System are guaranteed through scoping, identifying and assessing risks and controls (at corporate and process level, through risk assessment and monitoring activities), and the relevant information flows (reporting).

The main risks identified, monitored and managed by Italgas within the scope of corporate risks are: (i) market risk resulting from exposure to interest rates and natural gas price fluctuations; (ii) credit risk resulting from the possibility of default by a counterparty; (iii) liquidity risk resulting from the lack of financial resources to fulfil short-term commitments; (iv) rating risk; (v) default risk and debt covenants; (vi) operational risk and (vii) specific risks linked to the sectors in which the group operates.

## **Fintecna Group**

The main operational risk factors concerning Fintecna, as parent company of the Fintecna group, and the special purpose entities (subject to the direct control of Fintecna) dedicated to liquidation activities, relate to the handling of ongoing complex litigation mostly related to the companies already in liquidation that have come under its control over the years. Referring to the mentioned special purpose entities, other operational risk factors are those related to the management of environmental remediation and the acquired real estate assets. Taking into consideration the complexity and considerable uncertainty of these situations, Fintecna's directors – acting on the best available information – periodically update the evaluations of the adequacy of the provisions recognised in the financial statements.

In addition, Fintecna is subject to, *inter alia*, (i) liquidity risk, (ii) credit and counterparty risk, (iii) other financial risks and (iv) risks arising out of legal disputes (see also "*Description of Cassa depositi e prestiti S.p.A. – Legal Proceedings – Legal disputes relating to certain subsidiaries of CDP*").

Furthermore, particular attention is given by the company to the compliance risk, considering the possible reputational implications that could arise from it and in connection with environmental, health and safety aspects.

## **Fincantieri Group**

The performance of Fincantieri and its subsidiaries (the "**Fincantieri Group**") is strongly dependent on changes in their clients' workloads, and good relationship with some of them constitute one of the Fincantieri Group's strengths. The shipbuilding industry, in which Fincantieri operates, has historically been characterised by cyclical performance, responding to trends in its reference markets.

In order to mitigate the impact of the cyclical performance of the shipbuilding industry, in recent years the Fincantieri Group has pursued a strategy of diversification, expanding its business both at product level and at geographical level. In addition, commercial policies, the development of new products or an increase in production capacity by its competitors could lead to competition on price, with a corresponding reduction in profit margins.

Fincantieri seeks to maintain its competitive position in its business areas by ensuring high standards of product quality and innovation, alongside the pursuit of cost optimisation solutions and flexible use of technical and financial solutions in order to remain competitive in the industry in terms of its commercial offer.

In its pursuit of business opportunities in emerging markets, the Fincantieri Group seeks to mitigate country and/or corruption risk by focusing on commercial actions that are supported by intergovernmental agreements or other forms of cooperation between States.

Fincantieri Group is also subject to (i) risks connected to operational complexity, managing orders and outsourcing production; (ii) compliance risk; (iii) risks connected to exchange rate changes, (iv) risks connected to existing debt, and (v) risks associated with maintaining levels of competitiveness in the reference markets. Furthermore, Fincantieri is exposed to market risk, with specific regard to fluctuations in oil prices, given its exposure to the energy equipment sector through its subsidiary Vard Group AS, as well as in the prices of the main raw materials used, including but not limited to steel and copper.

### **CDP Immobiliare Group**

Following the acquisition of direct control of CDP Immobiliare by CDP, the new risk monitoring procedures for CDP Immobiliare's subsidiaries (which, together with CDP Immobiliare as parent company, compose the "**CDP Immobiliare Group**") including operational ones and the action plan for subsequent implementation are currently being shared with CDP.

In particular, the CDP Immobiliare Group is subject to, *inter alia*, (i) market risks (*i.e.* risks relating to fluctuations in the market value of properties in the portfolio, risk linked with interest rate trend), (ii) operational risks, (iii) liquidity risk, (iv) credit risk and (v) risks arising out of legal disputes (see also "*Description of Cassa depositi e prestiti S.p.A. – Legal Proceedings – Legal disputes relating to certain subsidiaries of CDP*").

### **CDP Equity**

CDP holds a 97.13 per cent. shareholding in CDP Equity, while Fintecna holds 2.87 per cent. CDP Equity operates in the acquisition of minority stakes in companies that have a relevant national interest for the Italian economy. As a statutory requirement, CDP Equity can only assist with investments in companies with a stable outlook in terms of financial, economic and balance sheet equilibrium.

CDP Equity has a solid profile in terms of liquidity risk. CDP Equity's balance sheet is currently debt-free while cash in excess is allocated mainly to time deposits and bank accounts and Italian sovereign debt bonds.

Nonetheless, CDP Equity is subject to market risk, with specific regard, among others, to fluctuations in the prices of shares raw materials (i.e. oil and natural gas) and exchange rates.

## **Risk factors relating to the Notes**

### ***Suitability of the Notes as an investment***

The Notes may not be a suitable investment for all Investors. Each potential investor in the Notes must determine the suitability of that investment in light of its own circumstances. In particular, each potential investor may wish to consider, either on its own or with the help of its financial and other professional advisers, whether it:

- (i) has sufficient knowledge and experience to make a meaningful evaluation of the Notes, the merits and risks of investing in the Notes and the information contained or incorporated by reference in this Base Prospectus or any applicable supplement;
- (i) has access to, and knowledge of, appropriate analytical tools to evaluate, in the context of its particular financial situation, an investment in the Notes and the impact the Notes will have on its overall investment portfolio;
- (ii) has sufficient financial resources and liquidity to bear all of the risks of an investment in the Notes, including Notes where the currency for principal or interest payments is different from the potential investor's currency;
- (iii) understands thoroughly the terms of the Notes and is familiar with the behaviour of financial markets; and
- (iv) is able to evaluate possible scenarios for economic, interest rate and other factors that may affect its investment and its ability to bear the applicable risks.

### ***Legal investment considerations may restrict certain investments***

The investment activities of certain investors are subject to legal investment laws and regulations, or review or regulation by certain authorities. Each potential investor should consult its legal advisers to determine whether and to what extent (1) Notes are legal investments for it, (2) Notes can be used as collateral for various types of borrowing, and (3) other restrictions apply to its purchase or pledge of any Notes. Financial institutions should consult their legal advisers or the appropriate regulators to determine the appropriate treatment of Notes under any applicable risk-based capital or similar rules.

### ***There is no active trading market for the Notes currently***

Notes issued under the Programme will be new securities which may not be widely distributed and for which there is currently no active trading market (unless in the case of any particular Tranche, such Tranche is to be consolidated with and form a single series with a Tranche of Notes which is already issued). If the Notes are traded after their initial issuance, they may trade at a discount to their initial offering price, depending upon prevailing interest rates, the market for similar securities, general economic conditions and the financial condition of the Issuer. Although

application has been made to be admitted to the Official List and traded on the regulated market of the Luxembourg Stock Exchange, there is no assurance that such application will be accepted, that any particular Tranche of Notes will be so admitted or that an active trading market will develop. Accordingly, there is no assurance as to the development or liquidity of any trading market for any particular Tranche of Notes. Illiquidity may have a severely adverse effect on the market value of Notes.

### ***Early Redemption of the Notes for tax reasons***

In the event that the Issuer would be obliged to increase the amounts payable in respect of any Notes due to any withholding or deduction for or on account of, any present or future taxes, duties, assessments or governmental charges of whatever nature imposed, levied, collected, withheld or assessed by or on behalf of the Republic of Italy or any political subdivision thereof or any authority therein or thereof having power to tax, the Issuer may redeem all outstanding Notes in accordance with the Conditions.

### ***Notes subject to optional redemption by the Issuer***

An optional redemption feature of Notes is likely to limit their market value. During any period when the Issuer may elect to redeem Notes, the market value of those Notes generally will not rise substantially above the price at which they can be redeemed. This also may be true prior to any redemption period.

The Issuer may be expected to redeem Notes when its cost of borrowing is lower than the interest rate on the Notes. At those times, an investor generally would not be able to reinvest the redemption proceeds at an effective interest rate as high as the interest rate on the Notes being redeemed and may only be able to do so at a lower rate. Potential investors should consider reinvestment risk in light of other investments available at that time.

### ***Fixed Rate Notes***

Investment in Fixed Rate Notes involves the risk that subsequent changes in market interest rates may adversely affect the value of such Notes.

### ***Floating Rate Notes***

The Issuer may issue Notes with interest determined by reference to the CMS Rate (a "**Relevant Factor**"). Potential investors should be aware that:

- (i) the market price of such Notes may be very volatile;
- (ii) they may receive no interest;
- (iii) payment of principal or interest may occur at a different time;
- (iv) a Relevant Factor may be subject to significant fluctuations that may not correlate with changes in interest rates, currencies or other indices;



- (v) if a Relevant Factor is applied to Notes in conjunction with a multiplier greater than one or contains some other leverage factor, the effect of changes in the Relevant Factor on principal or interest payable is likely to be magnified; and
- (vi) the timing of changes in a Relevant Factor may affect the actual yield to investors, even if the average level is consistent with their expectations. In general, the earlier the change in the Relevant Factor, the greater the effect on yield.

Furthermore, with regard to Floating Rate Notes, where the reference rate used to calculate the applicable interest rate turns negative, the interest rate will be below the margin, if any, or may be zero. Accordingly, where the rate of interest is equal to zero, the holders of such Floating Rate Notes may not be entitled to interest payments for certain or all interest periods, it being understood that under no circumstances shall the Rate of Interest (as defined in the Conditions) be less than zero.

### ***Risks relating to Notes which are linked to "benchmarks"***

The Euro Interbank Offered Rate ("**EURIBOR**"), London Interbank Offered Rate ("**LIBOR**") and other interest rate or other types of rates and indices which are deemed to be "benchmarks" are the subject of ongoing national and international regulatory discussions and proposals for reform. Some of these reforms are already effective whilst others are still to be implemented. Regulation (EU) No. 2016/1011 (the "**Benchmarks Regulation**") was published in the Official Journal of the European Union on 29 June 2016 and has applied from 1 January 2018 (with the exception of provisions specified in Article 59 (mainly on critical benchmarks) that have applied since 30 June 2016). The Benchmarks Regulation could have a material impact on any Notes linked to EURIBOR, LIBOR or another "benchmark" rate or index, in particular, if the methodology or other terms of the "benchmark" are changed in order to comply with the terms of the Benchmark Regulation, and such changes could (amongst other things) have the effect of reducing or increasing the rate or level, or affecting the volatility of the published rate or level, of the benchmark. In addition, the Benchmarks Regulation stipulates that each administrator of a "benchmark" regulated thereunder must be licensed by the competent authority of the Member State where such administrator is located. There is a risk that administrators of certain "benchmarks" will fail to obtain a necessary licence, preventing them from continuing to provide such "benchmarks". Other administrators may cease to administer certain "benchmarks" because of the additional costs of compliance with the Benchmarks Regulation and other applicable regulations, and the risks associated therewith. There is also a risk that certain benchmarks may continue to be administered but may in time become obsolete.

As an example of such benchmark reforms on 27 July 2017, the UK Financial Conduct Authority announced that it will no longer persuade or compel banks to submit rates for the calculation of the LIBOR benchmark after 2021 (the "**2017 FCA Announcement**"). On 12 July 2018, the FCA further announced that the LIBOR benchmark may cease to be a regulated benchmark under the Benchmarks Regulation (the "**2018 FCA Announcement**"). The 2017 FCA Announcement and the 2018 FCA Announcement indicate that the continuation of LIBOR on the current basis (or at all) cannot and will not be guaranteed after 2021.

In addition, on 29 November 2017, the Bank of England and the UK Financial Conduct Authority announced that, from January 2018, its Working Group on Sterling Risk-Free Rates has been mandated with implementing a broad-based transition to the Sterling Overnight Index Average ("**SONIA**") over the next four years across sterling bond, loan and derivative markets, so that SONIA is established as the primary sterling interest rate benchmark by the end of 2021.

Separate workstreams are also underway in Europe to reform EURIBOR using a hybrid methodology and to provide a fallback by reference to a euro risk-free rate (based on a euro overnight risk-free rate as adjusted by a methodology to create a term rate). On 13 September 2018, the working group on euro risk-free rates recommended Euro Short-term Rate ("**ESTR**") as the new risk-free rate. ESTR is expected to be published by the ECB by October 2019. In addition, on 21 January 2019, the euro risk free-rate working group published a set of guiding principles for fallback provisions in new euro denominated cash products (including bonds). The guiding principles indicate, among other things, that continuing to reference EURIBOR in relevant contracts may increase the risk to the euro area financial system.

Following the implementation of any such potential reforms, the manner of administration of benchmarks may change, with the result that they may perform differently than in the past, or the benchmark could be eliminated entirely, or there could be other consequences that cannot be predicted. Any of the above changes or any other consequential changes as a result of international or national reforms or other initiatives or investigations, could have a material adverse effect on the value of and return on any Notes linked to such benchmark (including Floating Rate Notes whose interest rates are linked to EURIBOR, LIBOR or any other such benchmark that is subject to reform). Furthermore, even prior to the implementation of any changes, uncertainty as to the nature of alternative reference rates and as to potential changes to such benchmark may adversely affect such benchmark during the term of the relevant Notes, the return on the relevant Notes and the trading market for securities (including the Notes) based on the same benchmark..

The Terms and Conditions of the Notes provide for certain fallback arrangements in the event that a Benchmark Event occurs, including if a published benchmark, such as EURIBOR, and any page on which such benchmark may be published (or any successor service) becomes unavailable, or if the Issuer, the Calculation Agent, any Paying Agent or any other party responsible for the calculation of the Rate of Interest (as specified in the relevant Final Terms) are no longer permitted lawfully to calculate interest on any Notes by reference to such benchmark under the Benchmarks Regulation or otherwise. Such fallback arrangements include the possibility that the rate of interest could be set by reference to a successor rate or an alternative rate, with or without an adjustment spread and may include amendments to the Terms and Conditions of the Notes to ensure the proper operation of the successor or replacement benchmark, all as determined by an independent adviser. An adjustment spread, if applied could be positive or negative and would be applied with a view to reducing or eliminating, to the fullest extent reasonably practicable in the circumstances, any economic prejudice or benefit (as applicable) to investors arising out of the replacement of a benchmark. However, it may not be possible to determine or apply an adjustment spread and even if an adjustment is applied, such adjustment spread may not be effective to reduce or eliminate economic prejudice to

investors. If no adjustment spread can be determined, a successor rate or alternative rate may nonetheless be used to determine the rate of interest. The use of a successor rate or alternative rate (including with the application of an adjustment spread) will still result in any Notes linked to or referencing a benchmark performing differently (which may include payment of a lower rate of interest) than they would if the benchmark were to continue to apply in its current form.

If, following the occurrence of a Benchmark Event, the Issuer is unable to appoint an independent advisor or the Independent Adviser appointed by it fails to determine a successor rate or an alternative rate, the ultimate fallback for the purposes of calculation of the rate of interest for a particular Interest Period may result in the rate of interest for the last preceding Interest Period being used. This may result in the effective application of a fixed rate for Floating Rate Notes based on the rate which was last observed on the Relevant Screen Page. In addition, due to the uncertainty concerning the availability of successor rates and alternative rates and the involvement of an independent adviser, there is a risk that the relevant fallback provisions may not operate as intended at the relevant time. Any such consequences could have a material adverse effect on the value of and return on any such Notes. Moreover, any of the above matters or any other significant change to the setting or existence of any relevant reference rate could affect the ability of the Issuer to meet its obligations under the Floating Rate Notes or could have a material adverse effect on the value or liquidity of, and the amount payable under, the Floating Rate Notes. Investors should consider these matters when making their investment decision with respect to the relevant Floating Rate Notes.

### ***Partly paid Notes***

The Issuer may issue Notes where the issue price is payable in more than one instalment. Failure to pay any subsequent instalment could result in an investor losing all of his investment.

### ***Notes issued at a substantial discount or premium***

The market value of Notes issued at a substantial discount or premium from their principal amount tend to fluctuate more in relation to general changes in interest rates than do prices for conventional interest-bearing securities. Generally, the longer the remaining term of the Notes, the greater the price volatility as compared to conventional interest-bearing securities with comparable maturities.

### ***Fluctuations in exchange rates may adversely affect the value of Notes.***

The Issuer will pay principal and interest on the Notes in the Specified Currency (as defined in the applicable Final Terms). This presents certain risks relating to currency conversions if Noteholder's financial activities are denominated principally in a currency or currency unit (the "**Noteholder's Currency**") other than the Specified Currency. These include the risk that there may be a material change in the exchange rate between the Specified Currency and the Noteholder's Currency or that a modification of exchange controls by the applicable authorities with jurisdiction over the Noteholder's Currency will be imposed. The Issuer has no control over the factors that generally affect these risks, such as economic, financial and political events and the supply and demand for the applicable currencies. Moreover, if payments on the Notes are determined by reference to a formula containing a

multiplier or leverage factor, the effect of any change in the exchange rates between the applicable currencies will be magnified. In recent years, exchange rates between certain currencies have been volatile and volatility between such currencies or with other currencies may be expected in the future. An appreciation in the value of the Noteholder's Currency relative to the Specified Currency would decrease (i) the Noteholder's Currency equivalent yield on the Notes, (ii) the Noteholder's Currency equivalent value of the principal payable on the Notes and (iii) the Noteholder's Currency equivalent market value of the Notes. Government and monetary authorities may impose (as some have done in the past) exchange controls that could adversely affect an applicable exchange rate. As a result, Noteholders may receive less interest or principal than expected, or no interest or principal.

***No physical document of title issued in respect of the Notes***

Notes issued under the Programme will be in dematerialised form and evidenced at any time through book entries pursuant to the relevant provisions of Legislative Decree No. 58 and in accordance with CONSOB and Bank of Italy Regulation. In no circumstance would physical documents of title be issued in respect of the Notes. While the Notes are represented by book entries, investors will be able to trade their beneficial interests only through Monte Titoli and the authorised financial intermediaries holding accounts on behalf of their customers with Monte Titoli. As the Notes are held in dematerialised form with Monte Titoli, investors will have to rely on the procedures of Monte Titoli and the financial intermediaries authorised to hold accounts therewith, for transfer, payment and communication with the Issuer.

***The Representative of the Noteholders may agree to modifications and waivers without convening a meeting of the Noteholders***

Pursuant to the Rules of Organisation of Noteholders, the Representative of the Noteholders for each Series of Notes may, without the consent of the Noteholders of such Series and without regard to the interests of particular Noteholders, agree to certain amendments to, or modifications of, or waivers or authorisations of any breach of the Conditions of the relevant Series of Notes. Any such modification, waiver, authorisation or determination shall be binding upon the Noteholders and, unless the Representative of the Noteholders determines otherwise, any such modification shall be notified to the Noteholders in accordance with Condition 18 (Notices) as soon as possible thereafter.

The Conditions contain provisions for calling meetings of Noteholders to consider matters affecting their interests generally. These provisions permit defined majorities to bind all Noteholders, including Noteholders who did not attend and vote at the relevant meeting and Noteholders who voted in a manner contrary to the majority.

***Conflicts may arise between the interests of the Calculation Agent and the interests of Noteholders***

The Issuer may appoint a Dealer as Calculation Agent in respect of an issuance of Notes under the Programme. In such a case the Calculation Agent is likely to be a member of an international financial group that is involved, in the ordinary course of its business, in a wide range of banking activities out of which conflicting interests may arise. Whilst such a Calculation Agent will, where relevant, have information barriers and procedures in place to manage conflicts of interest, it may in its other

banking activities from time to time be engaged in transactions involving an index or related derivatives which may affect amounts receivable by Noteholders during the term and on the maturity of the Notes or the market price, liquidity or value of the Notes and which could be deemed to be adverse to the interests of the Noteholders.

### ***Issues of further Series and interests of Noteholders***

Under the Programme, CDP may create and issue new Series of Notes without the consent of the existing Noteholders to raise funds to finance general funding purposes of the Issuer. Both prior to and following the occurrence of an Event of Default, all Notes will rank *pari passu* among themselves. Circumstances could potentially arise in which the interests of the holders of different Series of Notes could differ.

### ***Rating***

The Programme has been assigned a rating of "BBB" by Fitch Ratings, "Baa3" by Moody's, "BBB" by S&P and "BBB+" by Scope. Each of Fitch Ratings, Moody's, S&P and Scope is established in the EEA and registered under the CRA Regulation, and is included in the list of registered credit rating agencies published on the website of the European Securities and Markets Authority at <http://www.esma.europa.eu/page/List-registered-and-certified-CRAs>. Tranches of Notes issued under the Programme may be rated or unrated and, where an issue of Notes is rated, its rating will not necessarily be the same as the rating applicable to the Programme. The rating may not reflect the potential impact of all risks related to the structure, market, additional factors discussed above, and the other factors that may affect the value of the Notes. A security rating is not a recommendation to buy, sell or hold securities and may be subject to suspension, reduction or withdrawal at any time by the assigning rating agency. Any adverse change in an applicable credit rating could adversely affect the trading price for the Notes issued under the Programme.

Whether or not each credit rating applied for in relation to the relevant Tranche of Notes will be (1) issued by a credit rating agency established in the EEA and registered under the CRA Regulation, or (2) issued by a credit rating agency which is not established in the EEA but will be endorsed by a CRA which is established in the EEA and registered under the CRA Regulation, or (3) issued by a credit rating agency which is not established in the EEA but which is certified under the CRA Regulation, will be disclosed in the Final Terms. In general, European regulated investors are restricted from using a rating for regulatory purposes if such rating is not issued by a credit rating agency established in the EEA and registered under the CRA Regulation unless (1) the rating is provided by a credit rating agency not established in the EEA but endorsed by a credit rating agency established in the EEA and registered under the CRA Regulation or (2) the rating is provided by a credit rating agency not established in the EEA which is certified under the CRA Regulation..

***Notes issued, if any, as "Green Bonds" or "Social Bonds" or "Sustainability Bonds" may not be a suitable investment for all investors seeking exposure to green assets or social assets or sustainable assets***

If so specified in the relevant Final Terms, the Issuer may issue Notes under the Programme described as "green bonds" ("**Green Bonds**"), "social bonds" ("**Social Bonds**") and "sustainability bonds" ("**Sustainability Bonds**") in accordance with the principles set out by the International Capital Market Association ("**ICMA**") (respectively, the Green Bond Principles ("**GBP**"), the Social Bond Principles ("**SBP**") and the Sustainability Bond Guidelines ("**SBG**").

In such a case, prospective investors should have regard to the information set out at "*Reasons for the Offer, estimated net proceeds and total expenses*" in the applicable Final Terms and must determine for themselves the relevance of such information for the purpose of any investment in the Notes together with any other investigation such investors deem necessary, and must assess the suitability of that investment in light of their own circumstances. In particular, no assurance is given by the Issuer or the Dealers that the use of such proceeds for the funding of any green project or social project or sustainable project, as the case may be, will satisfy, whether in whole or in part, any present or future investor expectations or requirements as regards any investment criteria or guidelines with which such investor or its investments are required to comply, whether by any present or future applicable law or regulations or by its own by-laws or other governing rules or investment portfolio mandates. Furthermore, it should be noted that there is currently no clearly established definition (legal, regulatory or otherwise) of, nor market consensus as to what constitutes, respectively a "green" or a "social" or a "sustainable" project or as to what precise attributes are required for a particular project to be defined as "green" or "social" or "sustainable" or such other equivalent label, nor can any assurance be given that such a clear definition or consensus will develop over time. Accordingly, no assurance is or can be given to investors that any green or social or sustainable project, as the case may be, towards which proceeds of the Notes are to be applied will meet the investor expectations regarding such "green" or "social" or "sustainable" performance objectives or that any adverse social, green, sustainable and/or other impacts will not occur during the implementation of any green or social or sustainable project.

Furthermore, it should be noted that in connection with the issue of Green Bonds, Social Bonds and Sustainability Bonds, the Issuer may request a sustainability rating agency or sustainability consulting firm to issue a second-party opinion confirming that the relevant green and/or social and/or sustainable project, as the case may be have been defined in accordance with the broad categorisation of eligibility for green, social and sustainable projects set out in the GBP, the SBP and the SBG and/or a second-party opinion regarding the suitability of the Notes as an investment in connection with certain environmental, sustainability or social projects (any such second-party opinion, a "**Second-party Opinion**"). A Second-party Opinion may not reflect the potential impact of all risks related to the structure, market, additional risk factors discussed above and other factors that may affect the value of the Notes or the projects financed or refinanced toward an amount corresponding to the net proceeds of the relevant issue of Green Bonds, Social Bonds or Sustainability Bonds. A Second-party Opinion would not constitute a recommendation to buy, sell or hold the relevant Green Bonds or Social Bonds or Sustainability Bonds and would only be current as of the date it is released. A withdrawal of the Second-party Opinion may affect the value of such Green Bonds, Social Bonds or Sustainability Bonds and/or may have consequences for certain investors with portfolio mandates to invest in green or social or sustainable assets.

While it is the intention of the Issuer to apply the proceeds of Social Bonds, Green Bonds or Sustainability Bonds in, or substantially in, the manner described in the applicable Final Terms, there can be no assurance that the green, social or sustainable projects, as the case may be, will be capable of being implemented in or substantially in such manner and/or in accordance with any timing schedule and that accordingly the proceeds of the relevant Green Bonds, Social Bonds or Sustainability Bonds will be totally or partially disbursed for such projects. Nor can there be any assurance that such green, social or sustainable projects will be completed within any specified period or at all or with the results or outcome as originally expected or anticipated by the Issuer. Any such event or failure by the Issuer will not constitute an Event of Default under the relevant Green Bonds, Social Bonds or Sustainability Bonds.

Any such event or failure to apply the proceeds of the issue of the Notes for any green, social or sustainable projects as aforesaid may have a material adverse effect on the value of the Notes and/or result in adverse consequences for, amongst others, investors with portfolio mandates to invest in securities to be used for a particular purpose.

Any failure by the Issuer to comply with its reporting obligations in relation to Green Bonds, Social Bonds or Sustainability Bonds, as applicable, will not constitute an Event of Default under the relevant Notes.

***The Issuer believes that the risks described above are the principal risks inherent in the holding of Notes issued under Programme for holders of the Notes of any Series but the inability of the Issuer to pay interest or repay principal on the Notes of any Series may occur for other reasons. While the various structural elements described in this Base Prospectus are intended to lessen some of these risks for holders of Notes of any Series, there can be no assurance that these measures will be sufficient or effective to ensure payment to the holders of Notes of any Series of interest or principal on such Notes on a timely basis or at all.***

## GENERAL DESCRIPTION OF THE PROGRAMME

*This section must be read as an introduction to this Base Prospectus and any decision to invest in the Notes should be based on a consideration of the Base Prospectus as a whole, including the documents incorporated by reference.*

*Words and expressions defined in the "Conditions of the Notes" below or elsewhere in this Base Prospectus have the same meanings in this section.*

An overview of the terms and conditions of the Programme and the Notes appears below. The applicable terms of any Notes will be agreed between the Issuer and the relevant Dealer prior to the issue of the Notes. The following general description does not purport to be complete and is taken from, and is qualified in its entirety by, the remainder of this Base Prospectus and, in relation to the terms and conditions of any particular Tranche of Notes, the applicable Final Terms.

This general description constitutes a general description of the Programme for the purposes of Article 22.5(3) of Commission Regulation (EC) No 809/2004 implementing the Prospectus Directive.

The Base Prospectus and any supplement will only be valid for listing Notes on the Luxembourg Stock Exchange during the period of 12 months from the date of this Base Prospectus in an aggregate nominal amount which, when added to the aggregate nominal amount then outstanding of all Notes previously or simultaneously issued under the Programme, does not exceed EUR 10,000,000,000 or its equivalent in other currencies. For the purpose of calculating the euro equivalent of the aggregate nominal amount of Notes issued under the Programme from time to time:

- (a) the euro equivalent of Notes denominated in another currency of denomination (as specified in the applicable Final Terms in relation to the relevant Notes) shall be determined either as of the date on which agreement is reached for the issue of Notes or on the preceding day on which commercial banks and foreign exchange markets are open for business in Milan, in each case on the basis of the spot rate for the sale of the euro against the purchase of such currency of denomination in the Milan foreign exchange market quoted by any leading international bank selected by the Issuer on the relevant day of calculation; and
- (a) the euro equivalent of Zero Coupon Notes (as specified in the applicable Final Terms in relation to the relevant Notes) and other Notes issued at a discount or a premium shall be calculated in the manner specified above by reference to the net proceeds received by the Issuer for the relevant issue.

**Issuer:** Cassa depositi e prestiti *società per azioni* (the "**Issuer**" or "**CDP**"), a joint stock company incorporated on 12 December 2003 with limited liability in Italy under Article 5 of Italian Law Decree No. 269 of 30 September 2003, as converted with amendments into Law No. 326 of 24 November 2003 ("**Article 5**" or "**Law Decree 269**"), having its registered office at Via Goito No. 4, 00185 Rome,



Italy, registered with No. 80199230584 in the register of companies of Rome.

**Joint Arrangers:** CDP and Barclays Bank PLC.

**Dealers:** Banca IMI S.p.A., Barclays Bank Ireland PLC, Barclays Bank PLC, BNP Paribas, BofA Securities Europe SA, Citigroup Global Markets Europe AG, Citigroup Global Markets Limited, Commerzbank Aktiengesellschaft, Crédit Agricole Corporate and Investment Bank, Credit Suisse Securities (Europe) Limited, Deutsche Bank AG, HSBC France, J.P. Morgan Securities plc, Mediobanca – Banca di Credito Finanziario S.p.A., Merrill Lynch International, Morgan Stanley & Co. International plc, MPS Capital Services Banca per le Imprese S.p.A., Nomura International plc, Société Générale, UBS Europe SE and UniCredit Bank AG, and any other dealer appointed from time to time by the Issuer either generally in respect of the Programme or in relation to a particular Tranche of Notes (each a "**Dealer**" and together the "**Dealers**").

**Principal Paying Agent:** **BNP Paribas Securities Services**, a company incorporated under the laws of France as *société en commandite par actions*, having its registered office at 3, Rue d'Antin, 75002 Paris, France and offices at Piazza Lina Bo Bardi No. 3, 20124 Milan, Italy, or any other person for the time being acting as Principal Paying Agent of the Issuer pursuant to the Agency Agreement.

**Luxembourg Listing Agent:** **BNP Paribas Securities Services**, a *société en commandite par actions* (S.C.A.) incorporated under the laws of France, registered with the *Registre du Commerce et des Sociétés* of Paris under number 552 108 011, whose registered office is at 3, Rue d'Antin – 75002 Paris, France and acting for the purpose hereof through its **Luxembourg Branch** whose offices are at 60, avenue J. F. Kennedy, L-1855 Luxembourg and registered with the Luxembourg trade and companies register under number B. 86 862, or any other person for the time being acting as such, is the Luxembourg Listing Agent (in such capacity, the "**Luxembourg Listing Agent**").

**Calculation Agent:** The Calculation Agent in relation to any Tranche of Notes will be appointed by the Issuer on or prior to the relevant issue date of the Notes.

|   |   |
|---|---|
| <b>Representative of the Noteholders:</b> | <b>BNP Paribas Securities Services</b> , a company incorporated under the laws of France as <i>société en commandite par actions</i> , having its registered office at 3, Rue d'Antin, 75002 Paris, France and offices at Piazza Lina Bo Bardi No. 3, 20124 Milan, Italy or any other person for the time being acting as Representative of the Noteholders. The Representative of the Noteholders, as appointed for each Series of Notes, shall act as such pursuant to the Dealer Agreement, the subscription agreements in respect of the relevant Series of Notes and the Conditions. |
| <b>Listing and Admission to Trading:</b>  | Each Series may be admitted to trading on the regulated market of the Luxembourg Stock Exchange and/or admitted to listing, trading and/or quotation by any other listing authority, stock exchange and/or quotation system as may be agreed between the Issuer and the relevant Dealer(s) and specified in the relevant Final Terms or may be issued on the basis that they will not be admitted to listing, trading and/or quotation by any listing authority, stock exchange and/or quotation system.  |
| <b>Programme Amount:</b>                  | Up to Euro 10,000,000,000 (or its equivalent in other currencies) aggregate principal amount of Notes outstanding at any one time. The Issuer may increase the amount of the Programme in accordance with the terms of Dealer Agreement (as defined below). In connection with such increase, the Issuer shall prepare a supplement to the Base Prospectus.   |
| <b>Issuance in Series:</b>                | Notes will be issued in Series. Each Series may comprise one or more Tranches issued on different issue dates. The Notes of each Series will all be subject to identical terms, except that the issue date and the amount of the first payment of interest may be different in respect of different Tranches. The Notes of each Tranche will all be subject to identical terms in all respects.   |
| <b>Final Terms:</b>                       | Each Tranche will be the subject of the Final Terms prepared in relation thereto which, for the purposes of that Tranche only, complete the Conditions of the Notes and this Base Prospectus and must be read in conjunction with this Base Prospectus. The terms and conditions applicable to any particular Tranche of Notes are the Conditions of the Notes as completed by the relevant Final Terms.  |

|                                   |  |
|-----------------------------------|--|
| <b>Forms of Notes:</b>            | The Notes will be in bearer form and will be held in dematerialised form on behalf of the beneficial owners, until redemption or cancellation thereof, by Monte Titoli, for the account of the relevant Monte Titoli account holders. The Notes have been accepted for clearance by Monte Titoli. The Notes will at all times be held in book entry form and title to the Notes and will be evidenced by book entries pursuant to the relevant provisions of Italian Legislative Decree dated 24 February 1998, No. 58 as subsequently amended and supplemented (" <b>Legislative Decree No. 58</b> ") and in accordance with CONSOB and Bank of Italy Joint Regulation dated 13 August 2018, as subsequently amended and supplemented (" <b>CONSOB and Bank of Italy Regulation</b> "). No physical document of title will be issued in respect of the Notes. However, the Noteholders may ask the relevant intermediaries for certification pursuant to Article 83-quinquies of Legislative Decree No. 58. |
| <b>Fixed Rate Notes:</b>          | Fixed interest will be payable on such date or dates as may be agreed between the Issuer and the relevant Dealer and on redemption, and will be calculated on the basis of such Day Count Fraction as may be agreed between the Issuer and the relevant Dealer.  |
| <b>Floating Rate Notes:</b>       | Floating Rate Notes will bear interest by reference to the benchmark as may be specified in the relevant Final Terms as adjusted for any applicable margin/multiplier. Floating Rate Notes may also have a maximum interest rate, a minimum interest rate or both. Interest on Floating Rate Notes in respect of each Interest Period, as agreed prior to issue by the Issuer and the relevant Dealer(s), will be payable on such Interest Payment Dates, and will be calculated on the basis of such Day Count Fraction, as may be agreed between the Issuer and the relevant Dealer(s).  |
| <b>Benchmark Discontinuation:</b> | Condition 6.11 provides for certain fallback arrangements in the event that a Benchmark Event (as described in Condition 6.11) occurs in relation to an Original Reference Rate at any time when the Conditions provide for any remaining Rate of Interest (or any component part(s) thereof) to be determined by reference to such Original Reference Rate. IN such event, the Issuer shall use its reasonable endeavours to appoint and consult with an Independent Adviser, as soon as reasonably   |

practicable, to determine a Successor Rate, failing which an Alternative Rate (in accordance with Condition 6.11(ii)) and, in either case, an Adjustment Spread, if any (in accordance with Condition 6.11(iii)), as well as any Benchmark Amendments (in accordance with Condition 6.11(iv)). See Condition 6.11 for further information.

**Zero Coupon Notes:** Zero Coupon Notes will be offered and sold at a discount to their nominal amount and will not bear interest.

**Partly Paid Notes** Partly Paid Notes will be issued in the amount, as specified in the applicable Final Terms, and further instalments will be payable in the amounts and on the dates, as specified in the applicable Final Terms.

**Currencies:** Notes may be denominated in any currency or currencies, subject to compliance with all applicable legal and/or regulatory and/or central bank requirements.

**Issue Price:** Notes may be issued at any price and either on a fully or partly paid basis as specified in the relevant Final Terms.

**Maturities:** Any maturity subject, in relation to specific currencies, to compliance with all applicable legal and/or regulatory and/or central bank requirements.

**Redemption:** Subject to any purchase and cancellation or early redemption or repayment, Notes will be redeemable at par as specified in the applicable Final Terms. Unless permitted by then current laws and regulations, Notes (including Notes denominated in sterling) which have a maturity of less than one year and in respect of which the issue proceeds are to be accepted by the Issuer in the United Kingdom or whose issue otherwise constitutes a contravention of section 19 of the FSMA must have a minimum redemption amount of £100,000 (or its equivalent in other currencies).

**Optional Redemption:** Notes may be redeemed before their stated maturity at the option of the Issuer (either in whole or in part) and/or the Noteholders to the extent (if at all) specified in the relevant Final Terms.

**Tax Redemption:** Early redemption will be permitted for tax reasons as described in Condition 9.2 (*Redemption and Purchase - Redemption for tax reasons*).

**Interest:** Notes may be interest-bearing or non-interest bearing. Interest (if any) may accrue at a fixed rate or a floating rate or other variable rate and the method of calculating interest may vary between the issue date and the maturity date of the relevant Series.

**Denominations:** The Notes will be issued in such denominations as may be agreed between the Issuer and the relevant Dealer(s) save that the minimum denomination of each Note will be EUR 100,000 (or, if the Notes are denominated in a currency other than euro, the equivalent amount in such currency). Unless otherwise permitted by then current laws and regulations, Notes (including Notes denominated in sterling) which have a maturity of less than one year and in respect of which the issue proceeds are to be accepted by the Issuer in the United Kingdom or whose issue otherwise constitutes a contravention of section 19 of the FSMA will have a minimum denomination of £100,000 (or its equivalent in other currencies).

**Cross Default:** The Notes will have the benefit of a cross default as described in Condition 12 (*Events of Default*).

**Redenomination:** In respect of any Tranche of Notes, if the country of the Specified Currency becomes or, announces its intention to become, a Participating Member State (as defined in the Conditions), the Notes may be redenominated in Euro in accordance with Condition 21 (*Redenomination, Renominalisation and Reconventioning*) if so specified in the relevant Final Terms.

**Ratings:** The Programme is rated "BBB" by Fitch Ratings, "Baa3" by Moody's, "BBB" by S&P and "BBB+" by Scope. Each of Fitch Ratings, Moody's, S&P and Scope is established in the EEA and registered under the CRA Regulation, and is included in the list of registered credit rating agencies published on the website of the European Securities and Markets Authority at <http://www.esma.europa.eu/page/List-registered-and-certified-CRAs>.

Notes issued under the Programme may be rated or unrated. Where an issue of Notes is rated, its rating will not necessarily be the same as the rating applicable to the Programme or the rating(s) assigned to Notes previously issued.

**A rating is not a recommendation to buy, sell or**

**hold securities and may be subject to suspension, change or withdrawal at any time by the assigning rating agency.**

Whether or not each credit rating applied for in relation to the relevant Tranche of Notes will be (1) issued by a credit rating agency established in the EEA and registered under the CRA Regulation, or (2) issued by a credit rating agency which is not established in the EEA but will be endorsed by a CRA which is established in the EEA and registered under the CRA Regulation, or (3) issued by a credit rating agency which is not established in the EEA but which is certified under the CRA Regulation, will be disclosed in the Final Terms. In general, European regulated investors are restricted from using a rating for regulatory purposes if such rating is not issued by a credit rating agency established in the EEA and registered under the CRA Regulation unless (1) the rating is provided by a credit rating agency not established in the EEA but endorsed by a credit rating agency established in the EEA and registered under

the CRA Regulation or (2) the rating is provided by a credit rating agency not established in the EEA which is certified under the CRA Regulation.

**Selling Restrictions:** For a description of restrictions on offers, sales and delivery of the Notes, and on the distribution of offering materials, in the United States of America, the European Economic Area and Japan see "Subscription and Sale" below.

## DOCUMENTS INCORPORATED BY REFERENCE

The following documents shall be deemed to be incorporated by reference in, and to form part of, this Base Prospectus:

1. Article 5 of Italian Law Decree No. 269 of 30 September 2003, as converted with amendments into Law No. 326 of 24 November 2003, pursuant to which the Issuer has been transformed into a joint stock company, incorporated by reference in its entirety;
2. the By-laws (*Statuto*) of the Issuer, incorporated by reference in its entirety;
3. the audited consolidated annual financial statements (including the auditor's report thereon) of the Issuer in respect of the year ended on 31 December 2018 and the audited non-consolidated annual financial statements (including the auditor's report thereon) of the Issuer in respect of the year ended on 31 December 2018, all as included in the 2018 Annual Report;
4. the audited consolidated annual financial statements (including the auditor's report thereon) of the Issuer in respect of the year ended on 31 December 2017 and the audited non-consolidated annual financial statements (including the auditor's report thereon) of the Issuer in respect of the year ended on 31 December 2017, all as included in the 2017 Annual Report; and
5. the previous Base Prospectus dated 9 May 2018 (the "**2018 Base Prospectus**") prepared by the Issuer in connection with the Programme.

The tables below set out the relevant page references for the auditor's report and for the notes, the balance sheet, the income statement, the statement of comprehensive income, the changes in equity and the cash flow statement, in the Financial Statements above mentioned as set out in the Annual Reports published on the Issuer's website ([www.cdp.it](http://www.cdp.it)).

Any other information incorporated by reference that is not included in the cross-reference tables below is considered to be additional information to be disclosed to Investors rather than information required by the relevant Annexes of the Commission Regulation (EC) no 809/2004, as amended, implementing the Prospectus Directive, save that, for the 2018 Base Prospectus, the information not listed is either not relevant for the investors or covered elsewhere in the Base Prospectus and is not incorporated by reference herein.

### 2018 Annual Report

| <b>Non-consolidated<br/>financial statements</b> | <b>Page<br/>Reference</b> | <b>Consolidated financial<br/>statements</b> | <b>Page<br/>Reference</b> |
|--|---------------------------|--|---------------------------|
| 1. Balance sheet                                 | 116-117                   | 1. Balance sheet                             | 332-333                   |
| 2. Income statement                              | 118                       | 2. Income statement                          | 334                       |
| 3. Statement of<br>comprehensive<br>income       | 119                       | 3. Statement of<br>comprehensive<br>income   | 335                       |
| 4. Changes in equity                             | 120-121                   | 4. Changes in equity                         | 336-337                   |
| 5. Cash flow<br>statement                        | 122-123                   | 5. Cash flow statement                       | 338-339                   |
| 6. Notes to annual<br>financial<br>statements    | 124-304                   | 6. Notes to annual<br>financial statements   | 340-602                   |

| <b>Independent<br/>auditor's report</b> | <b>Page<br/>Reference</b> | <b>Independent auditor's<br/>report</b> | <b>Page<br/>Reference</b> |
|---|---------------------------|---|---------------------------|
| Auditor's report                        | 317-324                   | Auditor's report                        | 606-611                   |

### 2017 Annual Report

| <b>Non-consolidated<br/>financial statements</b> | <b>Page<br/>Reference<sup>2</sup></b> | <b>Consolidated financial<br/>statements</b> | <b>Page<br/>Reference</b> |
|--|---------------------------------------|--|---------------------------|
| 1. Balance sheet                                 | 126                                   | 1. Balance sheet                             | 264-265                   |
| 2. Income statement                              | 127                                   | 2. Income statement                          | 266                       |
| 3. Statement of<br>comprehensive income          | 127                                   | 3. Statement of<br>comprehensive<br>income   | 267                       |
| 4. Changes in equity                             | 128-129                               | 4. Changes in equity                         | 268-269                   |
| 5. Cash flow statement                           | 130-131                               | 5. Cash flow statement                       | 270-271                   |
| 6. Notes to annual<br>financial statements       | 132-243                               | 6. Notes to annual<br>financial statements   | 272-439                   |

| <b>Independent<br/>auditor's report</b> | <b>Page<br/>Reference</b> | <b>Independent auditor's<br/>report</b> | <b>Page<br/>Reference</b> |
|---|---------------------------|---|---------------------------|
| Auditors' report                        | 252-256                   | Auditors' report                        | 444-449                   |

### 2018 Base Prospectus

|                                   | <b>Page<br/>Reference</b> |
|-----------------------------------|---------------------------|
| Terms and Conditions of the Notes | 66 – 94                   |

---

<sup>2</sup> Page references refer to the English translation of the Annual Report published on the Issuer's website.



This Base Prospectus and the documents incorporated by reference are available for viewing on the Luxembourg Stock Exchange's website ([www.bourse.lu](http://www.bourse.lu)).

The Issuer will, at the specified offices of the Paying Agent (as defined herein), provide, free of charge, upon oral or written request, a copy of this Base Prospectus (or any document incorporated by reference in this Base Prospectus). Written or telephone requests for such documents should be directed to the specified office of the Paying Agent.

The non-consolidated financial statements of the Issuer as at and for the years ended 31 December 2018 and 31 December 2017, and the consolidated financial statements of CDP Group as at and for the year ended 31 December 2018 and 31 December 2017, have been audited by PricewaterhouseCoopers S.p.A. The foregoing Financial Statements, which attach those reports, are incorporated by reference into this Base Prospectus.

The non-consolidated financial statements and the consolidated financial statements referred to above have been prepared in accordance with the International Financial Reporting Standards (IFRSs) issued by the International Accounting Standards Board (IASB), including the SIC and IFRIC interpretations, endorsed by the European Union, as provided by Regulation (EC) No. 1606 of 19 July 2002, published in the Official Journal of the European Union L. 243 on 11 September 2002.

To the extent applicable, the non-consolidated financial statements and the consolidated financial statements have been prepared on the basis of Circular No. 262 of the Bank of Italy of 22 December 2005 as amended, which establishes the mandatory financial statements formats and compilation procedures, and also the contents of the notes to the financial statements.

## **SUPPLEMENT TO THE BASE PROSPECTUS**

Following the publication of this Base Prospectus a supplement may be prepared by the Issuer and approved by the CSSF in accordance with Article 16 of the Prospectus Directive. Statements contained in any such supplement (or contained in any document incorporated by reference therein) shall, to the extent applicable be deemed to modify or supersede statements contained in this Base Prospectus or in a document which is incorporated by reference in this Base Prospectus. Any statement so modified or superseded shall not, except as so modified or superseded, constitute a part of this Base Prospectus.

The Issuer will, in the event of any significant new factor, material mistake or inaccuracy relating to information included in this Base Prospectus which is capable of affecting the assessment of any Notes, prepare a supplement to this Base Prospectus or publish a new Base Prospectus for use in connection with any subsequent issue of Notes.

## TERMS AND CONDITIONS OF THE NOTES

*The following is the text of the terms and conditions of the Notes (the "**Conditions**") which, subject to completion in accordance with the provisions of the relevant Final Terms will apply to each Series of Notes.*

*In these Conditions, references to the "**holder**" of a Note or to "**Noteholders**" are to the beneficial owners of Notes issued in dematerialised form and evidenced in book entry form with Monte Titoli S.p.A. pursuant to the relevant provisions of Legislative Decree No. 58 and in accordance with CONSOB and Bank of Italy Regulation. No physical document of title will be issued in respect of Notes. Euroclear Bank S.A./N.V. ("**Euroclear**") and Clearstream Banking, société anonyme ("**Clearstream, Luxembourg**") are intermediaries authorised to operate through Monte Titoli S.p.A..*

### 1. Introduction

- 1.1 *Programme:* Cassa depositi e prestiti S.p.A. (the "**Issuer**") has established a Debt Issuance Programme (the "**Programme**") for the **issuance** of up to Euro 10,000,000,000 in aggregate principal amount of Notes. Such maximum amount may be increased at any time in accordance with the provisions of the Dealer Agreement (as defined below).
- 1.2 *Final Terms:* Notes issued under the Programme are issued in series (each a "**Series**") comprised of one or more tranches (each a "**Tranche**") of Notes which are (a) expressed to be consolidated and form a single Series and (b) have the same terms and conditions or terms and conditions which are the same in all respects save for the amount and date of the first payment of interest thereon and the date from which interest starts to accrue. Each Tranche is the subject of the Final Terms prepared in relation to such Tranche (each, the "**Final Terms**") which complete these Conditions. The terms and conditions applicable to any particular Series of Notes are these Conditions as completed by the relevant Final Terms.
- 1.3 *Agency Agreement:* On 20 May 2015, the Issuer has entered into an agency agreement (as amended or supplemented from time to time, the "**Agency Agreement**") with BNP Paribas Securities Services as principal paying agent (the "**Principal Paying Agent**", which expression includes any successor principal paying agent appointed from time to time in connection with the Notes), in relation to certain payment services in respect of the Notes.
- 1.4 *The Notes:* References herein to "**Notes**" shall be references to the Notes of the relevant Series which are the subject of the relevant Final Terms. Copies of the relevant Final Terms (where Notes the subject thereof are listed on the Luxembourg Stock Exchange) are available for inspection by Noteholders during normal business hours at the Specified Office of the Listing Agent, the initial Specified Office of which is 60 avenue J.F. Kennedy, L-1855 Luxembourg (Luxembourg).
- 1.5 *Summaries:* Certain provisions of these Conditions are summaries of the Agency Agreement and are subject to their detailed provisions. The holders of the Notes are bound by, and are deemed to have notice of, all the provisions of the Agency Agreement applicable to them. Copies of the Agency

Agreement are available for inspection by Noteholders during normal business hours at the Specified Offices of the Paying Agent, the initial Specified Offices of which are set out below.

- 1.6 *Rules of Organisation of Noteholders:* The rights and powers of the Noteholders may only be exercised in accordance with the relevant rules of organisation of Noteholders attached to the Agency Agreement (respectively, the "**Rules of Organisation**") which are deemed to form part of these Conditions. The Noteholders are deemed to have notice of and are bound by, and shall have the benefit of, *inter alia*, the terms of the Rules of Organisation.

## 2. Definitions and Interpretation

- 2.1 *Definitions:* In these Conditions the following expressions have the following meanings:

"**Accrual Yield**" has the meaning given thereto in the relevant Final Terms;

"**Additional Business Centre(s)**" means the city or cities specified as such in the relevant Final Terms;

"**Additional Financial Centre(s)**" means the city or cities specified as such in the relevant Final Terms;

"**Article 5**" means article 5 of Italian Law Decree No. 269 of 30 September 2003 (as converted with amendments into Law No. 326 of 24 November 2003), as subsequently amended and restated;

"**CONSOB and Bank of Italy Regulation**" means the regulation issued jointly by the Bank of Italy and CONSOB on 13 August 2018, as subsequently amended and supplemented;

"**Business Day**" means:

- (i) in relation to any sum payable in Euro, a TARGET Settlement Day and a day on which commercial banks and foreign exchange markets settle payments generally in each (if any) Additional Business Centre; and
- (ii) in relation to any sum payable in a currency other than Euro, a day on which commercial banks and foreign exchange markets settle payments generally in London, in the Principal Financial Centre of the relevant currency and in each (if any) Additional Business Centre;

"**Business Day Convention**", in relation to any particular date, has the meaning given thereto in the relevant Final Terms and, if so specified in the relevant Final Terms, may have different meanings in relation to different dates and, in this context, the following expressions shall have the following meanings:

- (i) "**Following Business Day Convention**" means that the relevant date shall be postponed to the first following day that is a Business Day;

- (ii) **"Modified Following Business Day Convention"** or **"Modified Business Day Convention"** means that the relevant date shall be postponed to the first following day that is a Business Day unless that day falls in the next calendar month in which case that date will be the first preceding day that is a Business Day;
- (iii) **"Preceding Business Day Convention"** means that the relevant date shall be brought forward to the first preceding day that is a Business Day;
- (iv) **"FRN Convention", "Floating Rate Convention" or "Eurodollar Convention"** means that each relevant date shall be the date which numerically corresponds to the preceding such date in the calendar month which is the number of months specified in the relevant Final Terms as the Specified Period after the calendar month in which the preceding such date occurred *provided, however, that:*
  - (A) if there is no such numerically corresponding day in the calendar month in which any such date should occur, then such date will be the last day which is a Business Day in that calendar month;
  - (B) if any such date would otherwise fall on a day which is not a Business Day, then such date will be the first following day which is a Business Day unless that day falls in the next calendar month, in which case it will be the first preceding day which is a Business Day; and
  - (C) if the preceding such date occurred on the last day in a calendar month which was a Business Day, then all subsequent such dates will be the last day which is a Business Day in the calendar month which is the specified number of months after the calendar month in which the preceding such date occurred; and
- (v) **"No Adjustment"** means that the relevant date shall not be adjusted in accordance with any Business Day Convention;

**"Calculation Agent"** means the entity specified in the relevant Final Terms to act as calculation agent in respect of the relevant Notes pursuant to the Conditions, the relevant Final Terms and the Agency Agreement;

**"Calculation Amount"** has the meaning given in the relevant Final Terms;

**"Cap"** means a percentage per annum as specified in the relevant Final Terms;

**"CMS Rate"** shall mean the applicable swap rate for swap transactions in the Reference Currency with a maturity of the Designated Maturity, expressed as a percentage, which appears on the Relevant Screen Page as at the Relevant Time on the Interest Determination Date in question, all as determined by the Calculation Agent;

"**CMS Rate 1**" and "**CMS Rate 2**" shall mean the CMS Rate with a particular Designated Maturity as specified in the relevant Final Terms;

"**CMS Reference Banks**" means (i) where the Reference Currency is Euro, the principal office of five major banks in the Euro-zone inter-bank market, (ii) where the Reference Currency is Sterling, the principal London office of five major banks in the London inter-bank market, (iii) where the Reference Currency is United States dollars, the principal New York City office of five major banks in the New York City inter-bank market, or (iv) in the case of any other Reference Currency, the principal Relevant Financial Centre office of five major banks in the Relevant Financial Centre inter-bank market, in each case selected by the Calculation Agent;

"**Day Count Fraction**" means, in respect of the calculation of an amount for any period of time (the "**Calculation Period**"), such day count fraction as may be specified in these Conditions or the relevant Final Terms and:

- (i) if "**Actual/Actual (ICMA)**" is so specified, means:
  - (a) where the Calculation Period is equal to or shorter than the Regular Period during which it falls, the actual number of days in the Calculation Period divided by the product of (1) the actual number of days in such Regular Period and (2) the number of Regular Periods in any year; and
  - (b) where the Calculation Period is longer than one Regular Period, the sum of:
    - (1) the actual number of days in such Calculation Period falling in the Regular Period in which it begins divided by the product of (1) the actual number of days in such Regular Period and (2) the number of Regular Periods in any year; and
    - (2) the actual number of days in such Calculation Period falling in the next Regular Period divided by the product of (a) the actual number of days in such Regular Period and (2) the number of Regular Periods in any year;
- (ii) if "**Actual/365**" or "**Actual/Actual (ISDA)**" is so specified, means the actual number of days in the Calculation Period divided by 365 (or, if any portion of the Calculation Period falls in a leap year, the sum of (A) the actual number of days in that portion of the Calculation Period falling in a leap year divided by 366 and (B) the actual number of days in that portion of the Calculation Period falling in a non-leap year divided by 365);
- (iii) if "**Actual/365 (Fixed)**" is so specified, means the actual number of days in the Calculation Period divided by 365;
- (iv) if "**Actual/360**" is so specified, means the actual number of days in the Calculation Period divided by 360;

- (v) if "**30/360**" is so specified, means the number of days in the Calculation Period divided by 360 (the number of days to be calculated on the basis of a year of 360 days with 12 30-day months (unless (i) the last day of the Calculation Period is the 31 day of a month but the first day of the Calculation Period is a day other than the 30<sup>th</sup> or 31<sup>st</sup> day of a month, in which case the month that includes that last day shall not be considered to be shortened to a 30-day month, or (ii) the last day of the Calculation Period is the last day of the month of February, in which case the month of February shall not be considered to be lengthened to a 30-day month)); and
- (vi) if "**30E/360**" or "**Eurobond Basis**" is so specified means, the number of days in the Calculation Period divided by 360 (the number of days to be calculated on the basis of a year of 360 days with 12 30-day months, without regard to the date of the first day or last day of the Calculation Period unless, in the case of the final Calculation Period, the date of final maturity is the last day of the month of February, in which case the month of February shall not be considered to be lengthened to a 30-day month);

"**Dealer Agreement**" means the dealer agreement entered into on 20 May 2015 (as amended or supplemented from time to time) by the Issuer, the Dealers and the Representative of the Noteholders setting out the terms of issue of any Series of Notes and the terms of appointment of the Representative of the Noteholders in respect of each such Series, as amended and supplemented from time to time;

"**Early Redemption Amount**" means, in respect of any Note, its principal amount or such other amount as may be specified in, or determined in accordance with, the relevant Final Terms;

"**Extraordinary Resolution**" has the meaning given thereto in the Rules of Organisation;

"**Final Redemption Amount**" means, in respect of any Note, its principal amount, subject to any purchase, cancellation, early redemption or repayment;

"**Fixed Coupon Amount**" has the meaning given thereto in the relevant Final Terms;

"**Floor**" means a percentage per annum as specified in the relevant Final Terms;

"**Guarantee**" means, in relation to any Indebtedness of any Person, any obligation of another Person to pay such Indebtedness including (without limitation):

- (i) any obligation to purchase such Indebtedness;
- (ii) any obligation to lend money, to purchase or subscribe shares or other securities or to purchase assets or services in order to provide funds for the payment of such Indebtedness;

- (iii) any indemnity against the consequences of a default in the payment of such Indebtedness; and
- (iv) any other agreement to be responsible for such Indebtedness;

**"Indebtedness"** means any indebtedness for money borrowed or raised including (without limitation) any indebtedness for or in respect of:

- (i) amounts raised by acceptance under any acceptance credit facility;
- (ii) amounts raised under any note purchase facility;
- (iii) the amount of any liability in respect of leases or hire purchase contracts which would, in accordance with applicable law and generally accepted accounting principles, be treated as finance or capital leases;
- (iv) the amount of any liability in respect of any purchase price for assets or services the payment of which is deferred for a period in excess of 60 days; and
- (v) amounts raised under any other transaction (including, without limitation, any forward sale or purchase agreement) having the commercial effect of a borrowing.

**"Interest Amount"** means, in relation to a Note and an Interest Period, the amount of interest payable in respect of that Note for that Interest Period;

**"Interest Commencement Date"** means, in relation to any Series or Tranche of Notes, the Issue Date of such Notes or such other date as may be specified as the Interest Commencement Date in the relevant Final Terms;

**"Interest Determination Date"** has the meaning given thereto in the relevant Final Terms;

**"Interest Payment Date"** means the date or dates specified as such in, or determined in accordance with the provisions of, the relevant Final Terms and, if a Business Day Convention is specified in the relevant Final Terms, as the same may be adjusted in accordance with the relevant Business Day Convention;

**"Interest Period"** means each period beginning on (and including) the Interest Commencement Date or any Interest Payment Date and ending on (but excluding) the next Interest Payment Date;

**"ISDA Definitions"** means the 2006 ISDA Definitions (as amended and updated as at the date of issue of the first Tranche of the Notes of the relevant Series (as specified in the relevant Final Terms) as published by the International Swaps and Derivatives Association, Inc.);

**"Issue Date"** has the meaning given thereto in the relevant Final Terms;

**"Legislative Decree No. 58"** means the Italian Legislative Decree No. 58 of 24 February 1998, as subsequently amended;



**"Leverage"** means a percentage number as specified in the relevant Final Terms;

**"Margin"** means a percentage per annum as specified in the relevant Final Terms;

**"Maturity Date"** has the meaning given thereto in the relevant Final Terms;

**"Maximum Redemption Amount"** has the meaning given thereto in the relevant Final Terms;

**"Minimum Redemption Amount"** has the meaning given thereto in the relevant Final Terms;

**"Monte Titoli"** means Monte Titoli S.p.A., with registered office and principal place of business at Piazza degli Affari 6, 20123 Milan, Italy, or any successor clearing system thereto;

**"Monte Titoli Account Holders"** means any authorised financial intermediary institution entitled to hold accounts on behalf of their customers with Monte Titoli and includes any depositary banks appointed by Euroclear and Clearstream, Luxembourg;

**"Optional Redemption Amount (Call)"** means, in respect of any Note, its principal amount or such other amount as may be specified in, or determined in accordance with, the relevant Final Terms;

**"Optional Redemption Amount (Put)"** means, in respect of any Note, its principal amount or such other amount as may be specified in, or determined in accordance with, the relevant Final Terms;

**"Optional Redemption Date (Call)"** has the meaning given thereto in the relevant Final Terms;

**"Optional Redemption Date (Put)"** has the meaning given thereto in the relevant Final Terms;

**"Participating Member State"** means a Member State of the European Communities which adopts the Euro as its lawful currency in accordance with the Treaty;

**"Payment Business Day"** means:

- (i) if the currency of payment is Euro, any day which is:
  - (A) a day on which banks in the relevant place of presentation are open for presentation and payment of bearer debt securities and for dealings in foreign currencies; and
  - (B) in the case of payment by transfer to an account, a TARGET Settlement Day and a day on which dealings in foreign currencies may be carried on in each (if any) Additional Financial Centre; or

- (ii) if the currency of payment is not Euro, any day which is:
  - (A) a day on which banks in the relevant place of presentation are open for presentation and payment of bearer debt securities and for dealings in foreign currencies; and
  - (B) in the case of payment by transfer to an account, a day on which dealings in foreign currencies may be carried on in the Principal Financial Centre of the currency of payment and in each (if any) Additional Financial Centre;

**"Person"** means any individual, company, corporation, firm, partnership, joint venture, association, organisation, state or agency of a state or other entity, whether or not having separate legal personality;

**"Principal Financial Centre"** means, in relation to any currency, the principal financial centre for that currency provided, however, that:

- (i) in relation to Euro, it means the principal financial centre of such Member State of the European Communities as is selected (in the case of a payment) by the payee or (in the case of a calculation) by the Calculation Agent; and
- (ii) in relation to Australian dollars, it means either Sydney or Melbourne and, in relation to New Zealand dollars, it means either Wellington or Auckland; in each case as is selected (in the case of a payment) by the payee or (in the case of a calculation) by the Calculation Agent;

**"Put Option Notice"** means a notice to be delivered to a Paying Agent by any Noteholder wanting to exercise a right to redeem a Note at the option of the Noteholder;

**"Rate of Interest"** means the rate or rates (expressed as a percentage per annum) of interest payable in respect of the Notes specified in the relevant Final Terms or calculated or determined in accordance with the provisions of these Conditions and/or the relevant Final Terms;

**"Redemption Amount"** means, as appropriate, the Final Redemption Amount, the Early Redemption Amount, the Optional Redemption Amount (Call), the Optional Redemption Amount (Put), or such other amount in the nature of a redemption amount as may be specified in the relevant Final Terms;

**"Reference Banks"** has the meaning given thereto in the relevant Final Terms or, if none, four major banks selected by the Calculation Agent in the market that is most closely connected with the Reference Rate;

**"Reference Currency"** has the meaning given in the relevant Final Terms;

**"Reference Price"** has the meaning given thereto in the relevant Final Terms;

**"Reference Rate"** has the meaning given in the relevant Final Terms;

**"Regular Period"** means:

- (i) in the case of Notes where interest is scheduled to be paid only by means of regular payments, each period from and including the Interest Commencement Date to but excluding the first Interest Payment Date and each successive period from and including one Interest Payment Date to but excluding the next Interest Payment Date;
- (ii) in the case of Notes where, apart from the first Interest Period, interest is scheduled to be paid only by means of regular payments, each period from and including a Regular Date falling in any year to but excluding the next Regular Date, where **"Regular Date"** means the day and month (but not the year) on which any Interest Payment Date falls; and
- (iii) in the case of Notes where, apart from one Interest Period other than the first Interest Period, interest is scheduled to be paid only by means of regular payments, each period from and including a Regular Date falling in any year to but excluding the next Regular Date, where **"Regular Date"** means the day and month (but not the year) on which any Interest Payment Date falls other than the Interest Payment Date falling at the end of the irregular Interest Period;

**"Relevant Date"** means, in relation to any payment, whichever is the later of (a) the date on which the payment in question first becomes due and (b) if the full amount payable has not been received in the Principal Financial Centre of the currency of payment by the Principal Paying Agent on or prior to such due date, the date on which (the full amount having been so received) notice to that effect has been given to the Noteholders;

**"Relevant Financial Centre"** has the meaning given thereto in the relevant Final Terms;

**"Relevant Screen Page"** means the page, section or other part of a particular information service (including, without limitation, Reuters) specified as the Relevant Screen Page in the relevant Final Terms, or such other page, section or other part as may replace it on that information service or such other information service, in each case, as may be nominated by the Person providing or sponsoring the information appearing there for the purpose of displaying rates or prices comparable to the Reference Rate;

**"Relevant Swap Rate"** means:

- (i) where the Reference Currency is Euro, the mid-market annual swap rate determined on the basis of the arithmetic mean of the bid and offered rates for the annual fixed leg, calculated on a 30/360 day count basis, of a fixed-for-floating euro interest rate swap transaction with a term equal to the Designated Maturity commencing on the first day of the relevant Interest Period and in a Representative Amount with an acknowledged dealer of good credit in the swap market, where the floating leg, in each case calculated on an Actual/360 day count basis, is equivalent to EUR-EURIBOR-Reuters (as defined in the ISDA

Definitions) with a designated maturity determined by the Calculation Agent by reference to standard market practice and/or the ISDA Definitions;

- (ii) where the Reference Currency is sterling, the mid-market semi-annual swap rate determined on the basis of the arithmetic mean of the bid and offered rates for the semi-annual fixed leg, calculated on an Actual/365 (Fixed) day count basis, of a fixed-for-floating Sterling interest rate swap transaction with a term equal to the Designated Maturity commencing on the first day of the relevant Interest Period and in a Representative Amount with an acknowledged dealer of good credit in the swap market, where the floating leg, in each case calculated on an Actual/365 (Fixed) day count basis, is equivalent (A) if the Designated Maturity is greater than one year, to GBP-LIBOR-BBA (as defined in the ISDA Definitions) with a designated maturity of six months or (B) if the Designated Maturity is one year or less, to GBP-LIBOR-BBA with a designated maturity of three months;
- (iii) where the Reference Currency is United States dollars, the mid-market semi-annual swap rate determined on the basis of the mean of the bid and offered rates for the semi-annual fixed leg, calculated on a 30/360 day count basis, of a fixed-for-floating United States dollar interest rate swap transaction with a term equal to the Designated Maturity commencing on the first day of the relevant Interest Period and in a Representative Amount with an acknowledged dealer of good credit in the swap market, where the floating leg, calculated on an Actual/360 day count basis, is equivalent to USD-LIBOR-BBA (as defined in the ISDA Definitions) with a designated maturity of three months; and
- (iv) where the Reference Currency is any other currency or if the Final Terms specify otherwise, the mid-market swap rate as determined in accordance with the applicable Final Terms;

**"Relevant Time"** has the meaning given thereto in the relevant Final Terms;

**"Representative Amount"** means an amount that is representative for a single transaction in the relevant market at the relevant time;

**"Representative of the Noteholders"** means BNP Paribas Securities Services as representative of the Noteholders of a relevant Series of Notes, appointed in the Subscription Agreement entered into in relation to each Series of Notes pursuant to the Dealer Agreement and set out in the relevant Final Terms, or any successor thereto appointed in accordance with the Rules of Organisation;

**"Security Interest"** means any mortgage, charge, pledge, lien or other security interest including, without limitation, anything analogous to any of the foregoing under the laws of any jurisdiction;

**"Specified Currency"** has the meaning given thereto in the relevant Final Terms;

"**Specified Denomination(s)**" has the meaning given thereto in the relevant Final Terms;

"**Specified Office**" has the meaning given thereto in the Agency Agreement;

"**Specified Period**" has the meaning given thereto in the relevant Final Terms;

"**Subsidiary**" means, in relation to any Person (the "**first Person**") at any particular time, any other Person (the "**second Person**"):

- (i) whose affairs and policies the first Person controls or has the power to control, whether by ownership of share capital, contract, the power to appoint or remove members of the governing body of the second Person or otherwise; or
- (ii) whose financial statements are, in accordance with applicable law and generally accepted accounting principles, consolidated with those of the first Person;

"**TARGET Settlement Day**" means any day on which the Trans-European Automated Real-Time Gross Settlement Express Transfer (TARGET) System is open;

"**Treaty**" means the Treaty establishing the European Communities, as amended; and

"**Zero Coupon Note**" means a Note specified as such in the relevant Final Terms.

2.2 *Interpretation:* In these Conditions:

- (i) any reference to principal shall be deemed to include the Redemption Amount, any additional amounts in respect of principal which may be payable under Condition 11 (*Taxation*), any premium payable in respect of a Note and any other amount in the nature of principal payable pursuant to these Conditions;
- (ii) any reference to interest shall be deemed to include any additional amounts in respect of interest which may be payable under Condition 11 (*Taxation*) and any other amount in the nature of interest payable pursuant to these Conditions;
- (iii) references to Notes being "outstanding" shall be construed in accordance with the Agency Agreement;
- (iv) if an expression is stated in Condition 2.1 to have the meaning given thereto in the relevant Final Terms, but the relevant Final Terms gives no such meaning or specifies that such expression is "not applicable" then such expression is not applicable to the Notes; and

- (v) any reference to the Agency Agreement shall be construed as a reference to the Agency Agreement as amended and/or supplemented up to and including the Issue Date of the Notes.

### **3. Form, Denomination and Title**

- 3.1 *Form*: The Notes will be in bearer form and will be held in dematerialised form on behalf of the beneficial owners by Monte Titoli for the account of the relevant Monte Titoli Account Holders as of their respective date of issue. Monte Titoli shall act as depository for Euroclear and Clearstream, Luxembourg.
- 3.2 *Book entries*: The Notes will at all times be evidenced by book-entries pursuant to the relevant provisions of Legislative Decree No. 58 and in accordance with CONSOB and Bank of Italy Regulation. No physical document of title will be issued in respect of the Notes.
- 3.3 *Denomination*: The Notes are issued in the Specified Denomination(s) specified in the applicable Final Terms. Each Series of Notes will have one denomination only.
- 3.4 *Types of Notes*: The Notes may be Fixed Rate Notes, Floating Rate Notes, Zero Coupon Notes, Partly Paid Notes or a combination of any of the foregoing, depending upon the Interest Basis shown in the applicable Final Terms.

### **4. Status**

The Notes constitute direct, general, unconditional and unsubordinated obligations of the Issuer which will at all times rank *pari passu* among themselves and at least *pari passu* with all other present and future unsecured obligations of the Issuer, save for such obligations as may be preferred by provisions of law that are both mandatory and of general application.

### **5. Fixed Rate Note Provisions**

- 5.1 *Application*: This Condition 5 (*Fixed Rate Note Provisions*) is applicable to the Notes only if the Fixed Rate Note Provisions are specified in the relevant Final Terms as being applicable.
- 5.2 *Accrual of interest*: The Notes bear interest on their principal amount (or, if they are Partly Paid Notes, on the aggregate amount paid up) from the Interest Commencement Date at the Rate of Interest payable in arrear on each Interest Payment Date, subject as provided in Condition 10 (*Payments*). Each Note will cease to bear interest from the due date for final redemption unless payment of the Redemption Amount is improperly withheld or refused, in which case it will continue to bear interest in accordance with this Condition 5 (as well after as before judgment) until the day on which all sums due in respect of such Note up to that day are received by or on behalf of the relevant Noteholder.

- 5.3 *Fixed Coupon Amount:* The amount of interest payable in respect of each Note for any Interest Period shall be the relevant Fixed Coupon Amount and, if the Notes are in more than one Specified Denomination, shall be the relevant Fixed Coupon Amount in respect of the relevant Specified Denomination.
- 5.4 *Calculation of interest amount:* The amount of interest payable in respect of each Note for any period for which a Fixed Coupon Amount is not specified shall be calculated by the Calculation Agent by applying the Rate of Interest to the principal amount of such Note (or, if they are Partly Paid Notes, the aggregate amount paid up) multiplying the product by the relevant Day Count Fraction and rounding the resulting figure to the nearest sub-unit of the Specified Currency (half a sub-unit being rounded upwards). For this purpose a "**sub-unit**" means, in the case of any currency other than Euro, the lowest amount of such currency that is available as legal tender in the country of such currency and, in the case of Euro, means one cent.

## **6. Floating Rate Note Provisions**

- 6.1 *Application:* This Condition 6 (*Floating Rate Note Provisions*) is applicable to the Notes only if the Floating Rate Note Provisions are specified in the relevant Final Terms as being applicable.
- 6.2 *Accrual of interest:* The Notes bear interest on their nominal amount (or, if they are Partly Paid Notes, the aggregate amount paid up) from, and including, the Interest Commencement Date at the Rate of Interest payable in arrear on each Interest Payment Date, subject as provided in Condition 10 (*Payments*). Each Note will cease to bear interest from the due date for final redemption unless, upon due presentation, payment of the Redemption Amount is improperly withheld or refused, in which case it will continue to bear interest in accordance with this Condition (as well after as before judgment) until the day on which all sums due in respect of such Note up to that day are received by or on behalf of the relevant Noteholder.
- 6.3 *Screen Rate Determination (other than CMS Linked Interest Notes):* If Screen Rate Determination is specified in the relevant Final Terms as the manner in which the Rate(s) of Interest is/are to be determined, the Rate of Interest applicable to the Notes for each Interest Period will, subject to Condition 6.11, be determined by the Calculation Agent on the following basis:
- (i) if the Reference Rate is a composite quotation or customarily supplied by one entity, the Calculation Agent will determine the Reference Rate which appears on the Relevant Screen Page as of the Relevant Time on the relevant Interest Determination Date;
  - (ii) in any other case, the Calculation Agent will determine the arithmetic mean of the Reference Rates which appear on the Relevant Screen Page as of the Relevant Time on the relevant Interest Determination Date;
  - (iii) if, in the case of (i) above, such rate does not appear on that page or, in the case of (ii) above, fewer than two such rates appear on that page

or if, in either case, the Relevant Screen Page is unavailable, the Calculation Agent will:

- (A) request the principal Relevant Financial Centre office of each of the Reference Banks to provide a quotation of the Reference Rate at approximately the Relevant Time on the Interest Determination Date to prime banks in the Relevant Financial Centre interbank market in an amount that is representative for a single transaction in that market at that time; and
  - (B) determine the arithmetic mean of such quotations; and
- (iv) if fewer than two such quotations are provided as requested, the Calculation Agent will determine the arithmetic mean of the rates (being the nearest to the Reference Rate, as determined by the Calculation Agent) quoted by major banks in the Principal Financial Centre of the Specified Currency, selected by the Calculation Agent, at approximately 11.00 a.m. (local time in the Principal Financial Centre of the Specified Currency) on the first day of the relevant Interest Period for loans in the Specified Currency to leading European banks for a period equal to the relevant Interest Period and in an amount that is representative for a single transaction in that market at that time,

and the Rate of Interest for such Interest Period shall be the sum of the Margin and the rate or (as the case may be) the arithmetic mean so determined; *provided, however, that* if the Calculation Agent is unable to determine a rate or (as the case may be) an arithmetic mean in accordance with the above provisions in relation to any Interest Period, the Rate of Interest applicable to the Notes during such Interest Period will be the sum of the Margin and the rate or, as the case may be, the arithmetic mean last determined in relation to the Notes in respect of the immediately preceding Interest Period for which such rate or arithmetic mean was determined.

6.4 *Floating Rate Notes which are CMS Linked Interest Notes:* Where Screen Rate Determination is specified in the applicable Final Terms as the manner in which the Rate of Interest is to be determined, subject to Condition 6.11, the Rate of Interest for each Interest Period will be:

- (a) where "CMS Reference Rate" is specified as the Reference Rate in the applicable Final Terms, determined by the Calculation Agent by reference to the following formula:

$$\text{CMS Rate} + \text{Margin}$$

- (b) where "Leveraged CMS Reference Rate" is specified as the Reference Rate in the applicable Final Terms, determined by the Calculation Agent by reference to the following formula:

$$\text{Leverage} \times \text{CMS Rate}$$



- (c) where "Leveraged CMS Reference Rate 2" is specified as the Reference Rate in the applicable Final Terms, determined by the Calculation Agent by reference to the following formula:

$$\text{Leverage} \times \text{CMS Rate} + \text{Margin}$$

- (d) where "Steepner CMS Reference Rate" is specified as the Reference Rate in the applicable Final Terms, determined by the Calculation Agent by reference to the following formula:

Either:

- (i) where "Steepner CMS Reference Rate: Unleveraged" is specified in the applicable Final Terms:

$$\text{CMS Rate 1} - \text{CMS Rate 2}$$

or

- (ii) where "Steepner CMS Reference Rate: Leveraged" is specified in the applicable Final Terms:

$$\text{Leverage} \times [(\text{Min}(\text{CMS Rate 1}; \text{Cap}) - \text{CMS Rate 2})] + \text{Margin}$$

- (e) where "Call Spread CMS Reference Rate" is specified as the Reference Rate in the applicable Final Terms, determined by the Calculation Agent by reference to the following formula:

$$\text{Leverage} \times \text{Min} [\text{Max}(\text{CMS Rate} + \text{Margin}; \text{Floor}); \text{Cap}]$$

If the Relevant Screen Page is not available, the Calculation Agent shall request each of the CMS Reference Banks to provide the Calculation Agent with its quotation for the Relevant Swap Rate at approximately 11.00 a.m. (local time in the Principal Financial Centre of the Specified Currency) on the Interest Determination Date in question. If at least three of the CMS Reference Banks provide the Calculation Agent with such quotation, the CMS Rate for such Interest Period shall be the arithmetic mean of such quotations, eliminating the highest quotation (or, in the event of equality, one of the highest) and the lowest quotation (or, in the event of equality, one of the lowest).

If on any Interest Determination Date less than three or none of the CMS Reference Banks provides the Calculation Agent with such quotations as provided in the preceding paragraph, the CMS Rate shall be determined by the Calculation Agent in good faith on such commercial basis as considered appropriate by the Calculation Agent in its absolute discretion, in accordance with standard market practice.

- 6.5 *ISDA Determination*: If ISDA Determination is specified in the relevant Final Terms as the manner in which the Rate(s) of Interest is/are to be determined, the Rate of Interest applicable to the Notes for each Interest Period will be the sum of the Margin and the relevant ISDA Rate where "**ISDA Rate**" in relation

to any Interest Period means a rate equal to the Floating Rate (as defined in the ISDA Definitions) that would be determined by the Calculation Agent under an interest rate swap transaction if the Calculation Agent were acting as Calculation Agent for that interest rate swap transaction under the terms of an agreement incorporating the ISDA Definitions and under which:

- (i) the Floating Rate Option (as defined in the ISDA Definitions) is as specified in the relevant Final Terms;
- (ii) the Designated Maturity (as defined in the ISDA Definitions) is a period specified in the relevant Final Terms; and
- (iii) the relevant Reset Date (as defined in the ISDA Definitions) is either (A) if the relevant Floating Rate Option is based on the London inter-bank offered rate (LIBOR) or on the Euro-zone inter-bank offered rate (EURIBOR) for a currency, the first day of that Interest Period or (B) in any other case, as specified in the relevant Final Terms.

6.6 *Maximum or Minimum Rate of Interest:* If any Maximum Rate of Interest or Minimum Rate of Interest is specified in the relevant Final Terms, then the Rate of Interest shall in no event be greater than the maximum or be less than the minimum so specified.

6.7 *Calculation of Interest Amount:* The Calculation Agent will, as soon as practicable after the time at which the Rate of Interest is to be determined in relation to each Interest Period, calculate the Interest Amount payable in respect of each Note for such Interest Period. The Interest Amount will be calculated by applying the Rate of Interest for such Interest Period to the Calculation Amount of such Note (or, if it is a Partly Paid Note, the aggregate amount paid up) during such Interest Period and multiplying the product by the relevant Day Count Fraction and rounding the resulting figure to the nearest sub-unit of the Specified Currency (half a sub-unit rounded upwards). For this purpose a "**sub-unit**" means, in the case of any currency other than euro, the lowest amount of such currency that is available as legal tender in the country of such currency and, in the case of euro, means one cent. Where the Specified Denomination of a Floating Rate Note is the multiple of the Calculation Amount, the Interest Amount payable in respect of such Note shall be the product of the amounts (determined in the manner provided above) for the Calculation Amount and the amount by which the Calculation Amount is multiplied to reach the Specified Denomination without any further rounding.

6.8 *Calculation of other amounts:* If the relevant Final Terms specifies that any other amount is to be calculated by the Calculation Agent, the Calculation Agent will, as soon as practicable after the time or times at which any such amount is, as the case may be, to be determined, calculate the relevant amount. The relevant amount will be calculated by the Calculation Agent in the manner specified in the relevant Final Terms.

6.9 *Publication:* The Calculation Agent will cause each Rate of Interest and Interest Amount determined by it, together with the relevant Interest Payment Date, and any other amount(s) required to be determined by it together with any relevant payment date(s) to be notified in accordance with Condition 18

(*Notices*) to the Paying Agent, Monte Titoli, the Issuer, the Representative of the Noteholders, the Luxembourg Stock Exchange or each listing authority, stock exchange and/or quotation system (if any) by which the Notes have then been admitted to listing, trading and/or quotation as soon as practicable after such determination but (in the case of each Rate of Interest, Interest Amount and Interest Payment Date) in any event not later than the first day of the relevant Interest Period. Notice thereof shall also promptly be given to the Noteholders in accordance with Condition 18 (*Notices*). The Calculation Agent will be entitled to recalculate any Interest Amount (on the basis of the foregoing provisions) without notice in the event of an extension or shortening of the relevant Interest Period.

6.10 *Notifications etc:* All notifications, opinions, determinations, certificates, calculations, quotations and decisions given, expressed, made or obtained for the purposes of this Condition by the Calculation Agent will (in the absence of manifest error) be binding on the Issuer, the other Paying Agent(s), the Representative of the Noteholders and the Noteholders (subject as aforesaid) and no liability to any such person will attach to the Calculation Agent in connection with the exercise or non-exercise by it of its powers, duties and discretions for such purposes.

6.11 *Benchmark Discontinuation:*

Notwithstanding the provisions above in this Condition 6, if a Benchmark Event occurs in relation to an Original Reference Rate at any time when these Conditions provide for any remaining Rate of Interest (or any component part(s) thereof) to be determined by reference to such Original Reference Rate, then the following provisions shall apply.

(i) *Independent Adviser:* The Issuer shall use its reasonable endeavours to appoint and consult with an Independent Adviser, as soon as reasonably practicable, to determine a Successor Rate, failing which an Alternative Rate (in accordance with Condition 6.11 (ii)) and, in either case, an Adjustment Spread if any (in accordance with Condition 6.11 (iii)) and any Benchmark Amendments (in accordance with Condition 6.11(iv)).

An Independent Adviser appointed pursuant to this Condition 6.11 shall act in good faith and in a commercially reasonable manner as an expert and in consultation with the Issuer and (in the absence of bad faith, fraud or gross negligence) shall have no liability whatsoever to the Issuer, the Paying Agents, the Calculation Agent, any other party specified in the relevant Final Terms as being responsible for calculating the Rate of Interest or the Noteholders for any determination made by it or for any advice given to the Issuer in connection with to the operation of this Condition 6.11.

(ii) *Successor Rate or Alternative Rate:* If the Independent Adviser determines that:

(A) there is a Successor Rate, then such Successor Rate shall (subject to adjustment as provided in Condition 6.11 (iii))

subsequently be used in place of the Original Reference Rate to determine the relevant Rate(s) of Interest (or the relevant component part(s) thereof) for all relevant future payments of interest on the Notes (subject to the further operation of this Condition 6.11); or

- (B) there is no Successor Rate but that there is an Alternative Rate, then such Alternative Rate shall (subject to adjustment as provided in Condition 6.11 (iii)) subsequently be used in place of the Original Reference Rate to determine the relevant Rate(s) of Interest (or the relevant component part(s) thereof) for all relevant future payments of interest on the Notes (subject to the further operation of this Condition 6.11).
- (iii) *Adjustment Spread*: If the Independent Adviser determines (i) that an Adjustment Spread is required to be applied to the Successor Rate or the Alternative Rate (as the case may be) and (ii) the quantum of, or a formula or methodology for determining, such Adjustment Spread, then such Adjustment Spread shall be applied to the Successor Rate or the Alternative Rate (as the case may be for each subsequent determination of a relevant Rate of Interest (or a relevant component part thereof) by reference to such Successor Rate or Alternative Rate (as applicable).
- (iv) *Benchmark Amendments*: If any Successor Rate, Alternative Rate or Adjustment Spread is determined in accordance with this Condition 6.11 and the Independent Adviser determines (i) that amendments to these Conditions (including without limitation, amendments to the definitions of Day Count Fraction, Business Day, Relevant Screen Page, Interest Determination Date, Relevant Time, Relevant Financial Centre, Reference Banks, Principal Financial Centre, Business Day Convention or Additional Business Centre) are necessary to ensure the proper operation of such Successor Rate, Alternative Rate and/or Adjustment Spread (such amendments, the "**Benchmark Amendments**") and (ii) the terms of the Benchmark Amendments, then the Issuer shall, and subject to the Issuer giving notice thereof in accordance with Condition 6.11 (v), without any requirement for the consent or approval of Noteholders, vary these Conditions to give effect to such Benchmark Amendments with effect from the date specified in such notice.

In connection with any such variation in accordance with this Condition 6.11 (iv), the Issuer shall comply with the rules of any stock exchange or other relevant authority on which the Notes are for the time being listed or by which they have been admitted to trading.

- (v) *Notices, etc.*: The Issuer shall notify the Paying Agents and the Calculation Agent or any other party specified in the relevant Final Terms as being responsible for calculating the Rate of Interest and, in accordance with Condition 18, the Noteholders promptly of any Successor Rate, Alternative Rate, Adjustment Spread and the specific

terms of any Benchmark Amendments, determined under this Condition 6.11. Such notice shall be irrevocable and shall specify the effective date of the Benchmark Amendments, if any.

Where a different Margin or Maximum or Minimum Rate of Interest is to be applied to the relevant Interest Period from that which applied to the last preceding Interest Period, the Margin or Maximum or Minimum Rate of Interest relating to the relevant Interest Period shall be substituted in place of the Margin or Maximum or Minimum Rate of Interest relating to that last preceding Interest Period.

The Successor Rate or Alternative Rate and the Adjustment Spread (if any) and the Benchmark Amendments (if any) specified in such notice will (in the absence of manifest error or bad faith in the determination of the Successor Rate or Alternative Rate and the Adjustment Spread (if any) and the Benchmark Amendments (if any)) be binding on the Issuer, the Paying Agents, the Calculation Agent, any other party specified in the relevant Final Terms as being responsible for calculating the Rate of Interest, the Noteholders.

- (vi) *Survival of Original Reference Rate:* Without prejudice to the obligations of the Issuer under the provisions of this Condition 6.11, the Original Reference Rate and the fallback provisions provided for in Condition 6.3 will continue to apply unless and until a Benchmark Event has occurred and only then once the Paying Agents and Calculation Agent or such other party specified in the relevant Final Terms, as applicable, have been notified of the Successor Rate or Alternative Rate (as the case may be) and any Adjustment Spread (if applicable) and Benchmark Amendments (if applicable) in accordance with Condition 6.11 (v).
- (vii) *Fallbacks:* If, following the occurrence of a Benchmark Event and in relation to the determination of the Rate of Interest on the relevant Interest Determination Date, the Issuer is unable to appoint an Independent Adviser or the Independent Adviser appointed by it fails to determine a Successor Rate or Alternative Rate (as applicable) pursuant to this Condition 6.11 by such Interest Determination Date, the Rate of Interest applicable to the next succeeding Interest Period shall be equal to the Rate of Interest last determined in relation to the Notes in respect of the immediately preceding Interest Period (though substituting, where a different Margin or Maximum or Minimum Rate of Interest is to be applied to the relevant Interest Period from that which applied to the last preceding Interest Period, the Margin or Maximum or Minimum Rate of Interest relating to the relevant Interest Period, in place of the Margin or Maximum or Minimum Rate of Interest relating to that last preceding Interest Period).

For the avoidance of doubt, this Condition 6.11 shall apply to the determination of the Rate of Interest on the relevant Interest Determination Date only, and the Rate of Interest applicable to any

subsequent Interest Period(s) is subject to the subsequent operation of, and to adjustment as provided in, this Condition 6.11.

(viii) *Definitions:* In this Condition 6.11:

**"Adjustment Spread"** means either a spread (which may be positive or negative), or the quantum of the formula or methodology for calculating a spread, in either case, which the Independent Adviser determines should be applied to the Successor Rate or the Alternative Rate (as the case may be) to reduce or eliminate, to the fullest extent reasonably practicable in the circumstances, any economic prejudice or benefit (as the case may be) to Noteholders as a result of the replacement of the Original Reference Rate with the Successor Rate or the Alternative Rate (as the case may be) and is the spread, quantum formula or methodology which:

- (A) in the case of a Successor Rate, is formally recommended, or formally provided as an option for parties to adopt in relation to the replacement of the Original Reference Rate with the Successor Rate by any Relevant Nominating Body; or
- (B) in the case of an Alternative Rate or (where (A) above does not apply) in the case of a Successor Rate, the Independent Adviser determines is recognised or acknowledged as being in customary market usage in international debt capital markets transactions which reference the Original Reference Rate, where such rate has been replaced by the Successor Rate or the Alternative Rate (as the case may be); or
- (C) (if the Independent Adviser determines that (A) above does not apply and no such spread, quantum formula or methodology is recognised or acknowledged as being customary market usage as referred to in (B) above) to be appropriate;

**"Alternative Rate"** means an alternative to the Reference Rate which the Independent Adviser determines in accordance with Condition 6.11 (ii) has replaced the Original Reference Rate in customary market usage in the international debt capital markets for the purposes of determining rates of interest (or the relevant component part thereof) or if no such rate exists, the rate which is most comparable to the Original Reference Rate, for a comparable interest period and in the same Specified Currency as the Notes;

**"Benchmark Amendments"** has the meaning given to it in Condition 6.11 (iv);

**"Benchmark Event"** means:

- (A) the Original Reference Rate ceasing to be published for a period of at least 5 Business Days or ceasing to be calculated, administered or published;
- (B) the later of (i) the making of a public statement by the administrator of the Original Reference Rate that it will, on or before a specified date, cease publishing the Original Reference

Rate permanently or indefinitely (in circumstances where no successor administrator has been appointed that will continue publication of the Original Reference Rate) and (ii) the date falling six months prior to the specified date referred to in (B)(i) above;

- (C) the making of a public statement by the supervisor of the administrator of the Original Reference Rate that the Original Reference Rate has been permanently or indefinitely discontinued;
- (D) the later of (i) the making of a public statement by the supervisor of the administrator of the Original Reference Rate that the Original Reference Rate will, on or before a specified date, be permanently or indefinitely discontinued and (ii) the date falling six months prior to the specified date referred to in (D)(i) above;
- (E) the later of (i) the making of a public statement by the supervisor of the administrator of the Original Reference Rate that means the Original Reference Rate will be prohibited from being used or that its use will be subject to restrictions or adverse consequences, in each case on or before a specified date and (ii) the date falling six months prior to the specified date referred to in (E)(i) above; or
- (F) it has become unlawful for any Paying Agent, the Calculation Agent or such other party as specified in the relevant Final Terms to calculate any payments due to be made to any Noteholder or Couponholder using the Original Reference Rate including, without limitation, under the Benchmark Regulation (EU) 2016/1011, if applicable;

**"Independent Adviser"** means an independent financial institution of international repute or an independent financial adviser with appropriate expertise appointed by the Issuer under Condition 6.11 at its own expense;

**"Original Reference Rate"** means the originally-specified Reference Rate used to determine the relevant Rate of Interest (or any component part thereof) on the Notes;

**"Relevant Nominating Body"** means, in respect of the Original Reference Rate:

- (A) the central bank, reserve bank, monetary authority or any similar institution for the currency to which the Original Reference Rate relates, or any central bank or other supervisory authority which is responsible for supervising the administrator of the Original Reference Rate; or
- (B) any working group or committee sponsored by, chaired or co-chaired by or constituted at the request of (a) the central bank, reserve bank, monetary authority or any similar institution for the

currency to which the Original Reference Rate relates, (b) any central bank or other supervisory authority which is responsible for supervising the administrator of the Original Reference Rate, (c) a group of the aforementioned central banks or other supervisory authorities, or (d) the Financial Stability Board or any part thereof; and

**"Successor Rate"** means a successor to or replacement of the Original Reference Rate which is formally recommended by any Relevant Nominating Body.

## **7. Zero Coupon Note Provisions**

7.1 *Application:* This Condition 7 (*Zero Coupon Note Provisions*) is applicable to the Notes only if the Zero Coupon Note Provisions are specified in the relevant Final Terms as being applicable.

7.2 *Late payment on Zero Coupon Notes:* If the Redemption Amount payable in respect of any Zero Coupon Note is improperly withheld or refused, the Redemption Amount shall thereafter be an amount equal to the sum of:

- (i) the Reference Price; and
- (ii) the product of the Accrual Yield (compounded annually) being applied to the Reference Price on the basis of the relevant Day Count Fraction from (and including) the Issue Date to (but excluding) the day on which all sums due in respect of such Note up to that day are received by or on behalf of the relevant Noteholder.

## **8. Partly Paid Notes Provisions**

*Accrual of interest:* In the case of Partly Paid Notes (other than Partly Paid Notes which are Zero Coupon Notes), interest will accrue on the paid-up aggregate nominal amount of such Notes and otherwise as specified in the applicable Final Terms.

## **9. Redemption and Purchase**

9.1 *Scheduled redemption:* Unless previously redeemed, or purchased and cancelled, the Notes will be redeemed at their Final Redemption Amount on the Maturity Date, subject as provided in Condition 10 (*Payments*).

9.2 *Redemption for tax reasons:* The Notes may be redeemed at the option of the Issuer in whole, but not in part:

- (i) at any time (if the Floating Rate Note Provisions are not specified in the relevant Final Terms as being applicable); or
- (ii) on any Interest Payment Date (if the Floating Rate Note Provisions are specified in the relevant Final Terms as being applicable),



on giving not less than 30 nor more than 60 days' notice to the Noteholders in accordance with Condition 18 (*Notices*) and the Representative of the Noteholders (which notice shall be irrevocable), at their Early Redemption Amount, together with interest accrued (if any) to the date fixed for redemption, if:

- (A) the Issuer has or will become obliged to pay additional amounts as provided or referred to in Condition 11 (*Taxation*) as a result of any change in, or amendment to, the laws or regulations of the Republic of Italy or any political subdivision or any authority thereof or therein having power to tax, or any change in the application or official interpretation of such laws or regulations (including a holding by a court of competent jurisdiction), which change or amendment becomes effective on or after the date of issue of the relevant Tranche of the Notes; and
- (B) such obligation cannot be avoided by the Issuer taking reasonable measures available to it,

*provided, however*, that no such notice of redemption shall be given earlier than:

- (1) where the Notes may be redeemed at any time, 90 days prior to the earliest date on which the Issuer would be obliged to pay such additional amounts if a payment in respect of the Notes were then due; or
- (2) where the Notes may be redeemed only on an Interest Payment Date, 60 days prior to the Interest Payment Date occurring immediately before the earliest date on which the Issuer would be obliged to pay such additional amounts if a payment in respect of the Notes were then due.

Prior to the publication of any notice of redemption pursuant to this paragraph, the Issuer shall deliver to the Representative of the Noteholders (A) a certificate signed by a senior officer of the Issuer stating that the Issuer is entitled to effect such redemption and setting forth a statement of facts showing that the conditions precedent to the right of the Issuer so to redeem have occurred of and (B) an opinion of independent legal advisers of recognised standing to the effect that the Issuer has or will become obliged to pay such additional amounts as a result of such change or amendment. Upon the expiry of any such notice as is referred to in this Condition 9.2, the Issuer shall be bound to redeem the Notes in accordance with this Condition 9.2.

- 9.3 *Redemption at the option of the Issuer.* If the Call Option is specified in the relevant Final Terms as being applicable, the Notes may be redeemed at the option of the Issuer in whole or, if so specified in the relevant Final Terms, in part on any Optional Redemption Date (Call) at the relevant Optional Redemption Amount (Call) on the Issuer's giving not less than 30 nor more than 60 days' notice to the Noteholders and the Representative of the Noteholders in accordance with Condition 18 (*Notices*) (which notice shall be irrevocable and shall oblige the Issuer to redeem the Notes or, as the case

may be, the Notes specified in such notice on the relevant Optional Redemption Date (Call) at the Optional Redemption Amount (Call) plus accrued interest (if any) to such date).

- 9.4 *Partial redemption:* If the Notes are to be redeemed in part only on any date in accordance with Condition 9.3 (*Redemption at the option of the Issuer*), the Optional Redemption Amount (Call) will be divided among all the Noteholders of the relevant Series pro rata to the principal amount outstanding of the Notes then held by the individual Noteholders.
- 9.5 *Redemption at the option of Noteholders:* If the Put Option is specified in the relevant Final Terms as being applicable, the Issuer shall, at the option of the holder of any Note, redeem such Note on the Optional Redemption Date (Put) specified in the relevant Put Option Notice at the relevant Optional Redemption Amount (Put) together with interest (if any) accrued to such date. In order to exercise the option contained in this Condition 9.5, the holder of a Note must, not less than 30 nor more than 60 days before the relevant Optional Redemption Date (Put), deposit with any Paying Agent, with a copy to the Issuer and the Representative of the Noteholders, a duly completed irrevocable Put Option Notice in the form attached to the Agency Agreement. Upon delivery of a Put Option Notice and up to and including the Optional Redemption Date (Put), no transfer of title to the Note(s) for which the Put Option Notice will be allowed. At least 5 Business Days prior to the Optional Redemption Date (Put), the Issuer and the Principal Paying Agent shall notify Monte Titoli of the amount of Notes to be redeemed on the Optional Redemption Date (Put) and the aggregate Optional Redemption Amount (Put).
- 9.6 *No other redemption:* The Issuer shall not be entitled to redeem the Notes otherwise than as provided in paragraphs 9.1 to 9.5 above.
- 9.7 *Early redemption of Zero Coupon Notes:* Unless otherwise specified in the relevant Final Terms, the Redemption Amount payable on redemption of a Zero Coupon Note at any time before the Maturity Date shall be an amount equal to the sum of:
- (i) the Reference Price; and
  - (ii) the product of the Accrual Yield (compounded annually) being applied to the Reference Price from (and including) the Issue Date to (but excluding) the date fixed for redemption or (as the case may be) the date upon which the Note becomes due and payable.
- 9.8 Where such calculation is to be made for a period which is not a whole number of years, the calculation in respect of the period of less than a full year shall be made on the basis of such Day Count Fraction as may be specified in the Final Terms for the purposes of this Condition 9.8 or, if none is so specified, a Day Count Fraction of 30E/360.
- 9.9 *Redemption of Partly Paid Notes:* If the Notes are Partly Paid Notes, unless otherwise specified in the applicable Final Terms, they will be redeemed, whether at maturity, early redemption or otherwise, in accordance with the provisions of this Condition 9 and the applicable Final Terms.

9.10 *Purchase*: The Issuer may at any time purchase Notes in the open market or otherwise and at any price. Such Notes may be held, reissued, resold or, at the option of the Issuer, cancelled.

9.11 *Cancellation*: All Notes which are redeemed by the Issuer in accordance with this Condition 9 shall be cancelled and may not be reissued or resold.

## **10. Payments**

10.1 *Principal and interest*: Payment of principal and interest in respect of the Notes will be credited, according to the instructions of Monte Titoli, by the relevant Paying Agent on behalf of the Issuer to the accounts of those banks and authorised brokers whose accounts with Monte Titoli are credited with those Notes and thereafter credited by such banks and authorised brokers from such aforementioned accounts to the accounts of the beneficial owners of those Notes or through Euroclear and Clearstream, Luxembourg to the accounts with Euroclear and Clearstream, Luxembourg of the beneficial owners of those Notes, in accordance with the rules and procedures of Monte Titoli, Euroclear or Clearstream, Luxembourg, as the case may be.

10.2 *Payments subject to fiscal laws*: All payments in respect of the Notes are subject in all cases to (i) any applicable fiscal or other laws and regulations in the place of payment, but without prejudice to the provisions of Condition 11 (*Taxation*), and (ii) any withholding or deduction required pursuant to an agreement described in Section 1471(b) of the U.S. Internal Revenue Code of 1986 (the "**Code**") or otherwise imposed pursuant to Sections 1471 through 1474 of the Code, any regulations or agreements thereunder, official interpretations thereof, or any law implementing an intergovernmental approach thereto. No commissions or expenses shall be charged to the Noteholders in respect of such payments.

10.3 *Payments on business days*: If the due date for payment of any amount in respect of any Note is not a Payment Business Day, the holder shall not be entitled to payment of the amount due until the next succeeding Payment Business Day and shall not be entitled to any further interest or other payment in respect of any such delay.

10.4 *Principal Paying Agent*: The Issuer reserves the right at any time to vary or terminate the appointment of the Principal Paying Agent and to appoint another Principal Paying Agent. The Issuer will cause at least 30 days' prior notice of any replacement of the Principal Paying Agent to be given in accordance with Condition 18 (*Notices*).

## **11. Taxation**

11.1 *Gross up*: All payments of principal and interest in respect of the Notes by the Issuer, shall be made free and clear of, and without withholding or deduction for, any taxes, duties, assessments or governmental charges of whatsoever nature imposed, levied, collected, withheld or assessed by the Republic of Italy, as the case may be, or any political subdivision or any authority thereof or therein having power to tax, unless such withholding or deduction is required by law. In that event, the Issuer shall pay such additional amounts as

will result in the receipt by the Noteholders of such amounts as would have been received by them if no such withholding or deduction had been required, except that no such additional amounts shall be payable in respect of any Note:

- (i) held by a relevant holder or beneficial owner of the Notes which is liable to such taxes, duties, assessments or governmental charges in respect of such Note by reason of its having some connection with the Republic of Italy (including, by way of example, being a resident of the Republic of Italy) other than the mere holding of such Note; or
- (ii) held by any Noteholder who would be entitled to avoid such withholding or deduction by making a declaration of residence or non-residence or other similar claim for exemption and fails to do so in due time;
- (iii) in relation to any payment or deduction on principal, interest or other proceeds of any Note on account of *imposta sostitutiva* pursuant to Italian Legislative Decree No. 239, as amended or supplemented from time to time;
- (iv) in relation to any payments to be requested more than 30 days after the Relevant Date except to the extent that the relevant holder would have been entitled to such additional amounts if it had requested such payment in respect of such Note on the last day of such period of 30 days;
- (v) if such withholding or deduction is required pursuant to an agreement described in Section 1471(b) of the Code or otherwise imposed pursuant to Sections 1471 through 1474 of the Code, any regulations or agreements thereunder, any official interpretations thereof, or any law implementing an intergovernmental approach thereto;
- (vi) in relation to any payment to be requested in the Republic of Italy; and
- (vii) any combination of items (i) through (vi).

11.2 *Taxing jurisdiction*: If the Issuer becomes subject at any time to any taxing jurisdiction other than the Republic of Italy references in these Conditions to the Republic of Italy shall be construed as references to the Republic of Italy and/or such other jurisdiction.

## 12. Events of Default

12.1 If any of the following events (each an "**Event of Default**") occurs and is continuing, then the Representative of the Noteholders at its discretion may and, if so directed by an Extraordinary Resolution of all outstanding Series of Notes, shall (subject, in the case of the occurrence of any of the events mentioned in paragraph (b) (*Breach of other obligations*) below, to the Representative of the Noteholders having certified in writing that the happening of such event is in its opinion materially prejudicial to the interests of the Noteholders and, in all cases, to the Representative of the Noteholders

having been indemnified or provided with security to its satisfaction), give written notice to the Issuer declaring the Notes to be immediately due and payable, whereupon they shall become immediately due and payable at their principal amount together with accrued interest without further action or formality:

- (a) *Non-payment*: the Issuer fails to pay any amount of principal in respect of the Notes within one day, or fails to pay any amount of interest in respect of the Notes within three days, in each case, of the due date for payment thereof; or
- (b) *Breach of other obligations*: the Issuer defaults in the performance or observance of any of its other material obligations under or in respect of the Notes and such default (i) is, in the opinion of the Representative of the Noteholders, incapable of remedy or (ii) being a default which is, in the opinion of the Representative of the Noteholders, capable of remedy remains unremedied for 30 days or such longer period as the Representative of the Noteholders may agree upon with the Issuer, after the Representative of the Noteholders has given written notice thereof to the Issuer; or
- (c) Cross-default of Issuer:
  - (1) any Indebtedness of the Issuer which, taken individually or in the aggregate, exceeds EUR 100,000,000 (or its equivalent in any other currency or currencies) (i) is not paid when due or (as the case may be) within any applicable grace period, or (ii) becomes due and payable prior to its stated maturity by reason of default (howsoever described) by the Issuer; or
  - (2) the Issuer fails to pay when due any amount payable by it under any Guarantee of any Indebtedness, taken individually or in the aggregate, in excess of EUR 100,000,000 (or its equivalent in any other currency or currencies); or
- (d) *Unsatisfied judgment*: one or more judgment(s) or order(s) from which no further appeal or judicial review is permissible under applicable law for the payment of any amount/an amount in excess of Euro 10,000,000 (or its equivalent in any other currency or currencies), in aggregate, is rendered against the Issuer and continue(s) unsatisfied and unstayed for a period of 60 days after the date(s) thereof or, if later, the date therein specified for payment; or
- (e) *Security enforced*: a secured party takes possession, or a receiver, manager or other similar officer is appointed, of the whole or a substantial (in the opinion of the Representative of the Noteholders) part of the undertaking, assets and revenues of the Issuer, and such taking of possession or appointment is not terminated within 90 days of the date hereof; or

- (f) *Insolvency*: the Issuer:
- (1) is adjudicated or found bankrupt or insolvent; or
  - (2) becomes subject to any bankruptcy, compulsory liquidation, or otherwise becomes subject to or initiates or consents to judicial or administrative proceedings under any applicable insolvency, liquidation, composition, or other similar laws; or
  - (3) ceases generally to pay its debts or admits in writing its inability to pay its debts as they fall due; or
  - (4) enters into, or passes any resolution for, or becomes subject to any order by any competent court or administrative agency, or takes any action in relation to:
    - (A) any arrangement with its creditors generally or any calls of creditors; or
    - (B) the appointment of an administrative or other receiver, administrator, trustee, or other similar official in relation to the Issuer of the whole or substantially the whole of its undertakings or assets; or
- (g) *Winding up, etc.*: an order is made or an effective resolution is passed for the winding up, liquidation or dissolution of the Issuer (otherwise than for the purposes of or pursuant to an amalgamation, reorganisation or restructuring whilst solvent); or
- (h) *Unlawfulness*: it becomes unlawful for the Issuer to perform or comply with any of its obligations under or in respect of the Notes; or
- (i) *Corporate Reorganisation*: the Issuer ceases or threatens to cease to carry on the whole or a substantial part of its business, save for (i) the purposes of a reorganisation, restructuring, merger, amalgamation transfer or contribution of assets or other similar transaction on terms approved by the Representative of the Noteholders or (ii) the purposes of a Permitted Reorganisation.

For the purposes of this provision:

**Permitted Reorganisation** means, in respect of the Issuer, an amalgamation, merger, spin-off, reconstruction, reorganisation, restructuring, transfer or contribution of assets or other similar transaction (a **relevant transaction**) whilst solvent and whereby:

- (a) to the extent that the Issuer is not a surviving entity, the resulting company is a Successor in Business of the Issuer. **Successor in Business** means, in relation to the Issuer, any company which, as a result of relevant transaction, (i) assumes the obligations of the Issuer in respect of the Notes, and (ii) carries on, as a successor to the Issuer, the whole or substantially the

whole of the business carried on by the Issuer immediately prior thereto and (iii) beneficially owns the whole or substantially the whole of the undertaking, property and assets owned by the Issuer immediately prior thereto, or (iv) where item (ii) or (iii) is not complied with, no Rating Agency has announced a Rating Downgrade in respect of the Successor in Business or the Notes during the 90-day period following the announcement of a definitive agreement in respect of the relevant transaction, in each case to the extent ratings are assigned at the relevant time; or

- (b) to the extent that the Issuer is the surviving entity, the relevant transaction has no material adverse effect on the ability of the Issuer to perform all its liabilities (payment and otherwise) in respect of all then existing obligations of the Issuer of the Notes. For the purposes of this provision, "**material adverse effect**" will be deemed not to have occurred where no Rating Agency has announced a Rating Downgrade in respect of the Issuer or the Notes during the 90-day period following the announcement of a definitive agreement in respect of the relevant transaction, in each case to the extent ratings are assigned at the relevant time.

"**Fitch**" means Fitch Ratings Ltd. or any of its subsidiaries or their successors;

"**Moody's**" means Moody's Investors Service Ltd. or any of its subsidiaries or their successors;

"**Rating Agency**" means any of Fitch, Moody's and S&P and Scope;

"**Rating Date**" means the date falling one business day (being for this purpose a day on which banks are open for business in London) prior to the public announcement of a definitive agreement in respect of the relevant transaction;

"**Rating Downgrade**" means that the rating of the Notes or the Issuer which was assigned or existing as of the Rating Date by any Rating Agency is downgraded by at least one rating category below such rating of the Notes or, as appropriate, of the Issuer by such Rating Agency, and the official statement issued by such Rating Agency announcing the Rating Downgrade refers to the relevant transaction as a reason, in whole or in part, for such downgrade;

"**S&P**" means S&P Global Ratings Europe Ltd, a division of the McGraw Hill Companies, Inc. or any of its subsidiaries or their successors;

"**Scope**" means Scope Ratings GmbH or any of its subsidiaries or their successors; or

- (j) *Failure to Take Action*: at any time any act, condition or thing which is required to be done, fulfilled or performed by the Issuer in order (i) to

enable the Issuer lawfully to enter into, exercise its rights under and perform the obligations expressed to be assumed by it under and in respect of the Notes, (ii) to ensure that those obligations are legal, valid, binding and enforceable or (iii) to make the Notes admissible in evidence in the Republic of Italy, is not done, fulfilled or performed.

### **13. Enforcement**

13.1 No Noteholder may proceed directly against the Issuer to enforce its rights under the Notes unless the relevant action has been previously approved at a Meeting of the holders of all outstanding Series of Notes and the relevant Representative of the Noteholders has failed to take such action within a reasonable period of time. Following the service of a notice of occurrence of an Event of Default, the Representative of the Noteholders, in its capacity as legal representative of the Noteholders, shall be entitled, pursuant to articles 1411 and 1723 of the Italian Civil Code, and subject to being previously indemnified and secured to its or their satisfaction by the Noteholders, to commence any action against the Issuer in the interest of the Noteholders.

### **14. Meetings of Noteholders; Modifications, Consents and Waivers; the Representative of the Noteholders**

14.1 *Meetings of Noteholders:* The Rules of Organisation scheduled to the Agency Agreement contain provisions for convening meetings of Noteholders to consider any matter affecting their interests, including the sanctioning by Extraordinary Resolution of the Noteholders of a modification of the Notes (including these Conditions).

14.2 *Regard to Noteholders:* The Representative of the Noteholders of each Series of Notes is required, in connection with the exercise of its powers, authorities, duties and discretions under or in relation to the relevant Notes (including these Conditions), to have regard to the interests of the Noteholders, it shall have regard to the interests of the Noteholders as a class and, in particular but without prejudice to the generality of the foregoing, shall not have regard to, or be in any way liable for, the consequences of such exercise for individual Noteholders resulting from their being for any purpose domiciled or resident in, or otherwise connected with, or subject to the jurisdiction of, any particular territory and the Representative of the Noteholders shall not be entitled to require, nor shall any Noteholder be entitled to claim from the Issuer or any other person any indemnification or payment in respect of any tax consequence of any such exercise upon individual Noteholders.

14.3 *Appointment of the Representative of the Noteholders:* The appointment of the Representative of the Noteholders is made in the relevant Subscription Agreement in connection with any issue of Notes pursuant to the Dealer Agreement and confirmed in the relevant Final Terms. Each Noteholder is deemed to accept such appointment. The Representative of the Noteholders may be replaced in accordance with the provisions set out in the Rules of Organisation.

14.4 *Modification:* The Notes and these Conditions may be amended with the consent of the Representative of the Noteholders but, without the need of



convening a meeting of the relevant Noteholders (albeit without prejudice to the right of the Representative of the Noteholders to call such a meeting) to correct a manifest error or to effect a modification which is of a formal, minor or technical nature or to comply with mandatory provisions of law.

- 14.5 For the avoidance of doubt, any variation of the Conditions and the Agency Agreement to give effect to the Benchmark Amendments in accordance with Condition 6.11 shall not require the consent or approval of Noteholders.

## 15. Prescription

- 15.1 Claims against the Issuer for payments in respect of the Notes shall be prescribed and shall become void unless made within ten years (in the case of principal) or five years (in the case of interest) from the Relevant Date in respect thereof.
- 15.2 In this Condition 15 (*Prescription*), the "**Relevant Date**", in respect of a Note, is the date on which a payment in respect thereof first becomes due and payable or (if the full amount of the monies payable in respect of all Notes and accrued on or before that date has not been duly received by the Principal Paying Agent or the Representative of the Noteholders on or prior to such date) the date on which notice that the full amount of such monies has been received is duly given to the Noteholders in accordance with Condition 18 (*Notices*).

## 16. Agents

- 16.1 In acting under the Agency Agreement and in connection with the Notes, the Paying Agent act solely as agent of the Issuer and do not assume any obligations towards or relationship of agency or trust for or with any of the Noteholders.
- 16.2 The initial Paying Agent appointed by the Issuer and its initial specified office is listed below. The Paying Agent acts solely as agent of the Issuer and does not assume any obligation or relationship of agency or trust for or with any Noteholder. The Issuer reserves the right at any time to vary or terminate the appointment of the Paying Agent and to appoint a successor paying agent or Principal Paying Agent and additional or successor paying agents, provided that the Issuer shall at all times maintain:
- (a) a Principal Paying Agent in Italy whilst the Notes are deposited with Monte Titoli;
  - (b) if and for so long as the Notes are admitted to listing, trading and/or quotation by any listing authority, stock exchange and/or quotation system which requires the appointment of a Paying Agent in any particular place, the Issuer shall maintain a Paying Agent having its specified office in the place required by such listing authority, stock exchange and/or quotation system; and
  - (c) a Calculation Agent in relation to each Series of Notes.

Notice of any change in any of the Paying Agents or the Calculation Agent or in their specified offices shall promptly be given to the Noteholders.

## 17. Further Issues

- 17.1 The Issuer may from time to time, without the consent of the Noteholders, create and issue further notes having the same terms and conditions as the Notes in all respects (or in all respects except for the first payment of interest and the issue price) so as to form a single series with the outstanding Notes.

## 18. Notices

- 18.1 *Publication:* Any notice regarding the Notes, as long as the Notes are held through Monte Titoli, shall be deemed to have been duly given through the systems of Monte Titoli, and, as long as the Notes are listed on the Luxembourg Stock Exchange and the rules of such exchange so require, if published on the Luxembourg Stock Exchange website ([www.bourse.lu](http://www.bourse.lu)). Any such notice shall be deemed to have been given on the date of such publication or, if published more than once or on different dates, on the first date on which publication is made in the manner required in one of the newspapers referred to above.
- 18.2 *Variation:* The Representative of the Noteholders shall be at liberty to sanction some other method of giving notice to Noteholders of the relevant Series if, in its or their opinion, such other method is reasonable having regard to market practice then prevailing and to the rules of the stock exchange on which the Notes are then listed and provided that notice of such other method is given to the Noteholders in such manner as the Representative of the Noteholders shall require.

## 19. Currency Indemnity

- 19.1 If any sum due from the Issuer in respect of the Notes or any order or judgment given or made in relation thereto has to be converted from the currency (the "**first currency**") in which the same is payable under these Conditions or such order or judgment into another currency (the "**second currency**") for the purpose of (a) making or filing a claim or proof against the Issuer, (b) obtaining an order or judgment in any court or other tribunal or (c) enforcing any order or judgment given or made in relation to the Notes, the Issuer shall indemnify each Noteholder, on the written demand of such Noteholder addressed to the Issuer and delivered to the Issuer or to the Specified Office of the Principal Paying Agent, against any loss suffered as a result of any discrepancy between (i) the rate of exchange used for such purpose to convert the sum in question from the first currency into the second currency and (ii) the rate or rates of exchange at which such Noteholder may in the ordinary course of business purchase the first currency with the second currency upon receipt of a sum paid to it in satisfaction, in whole or in part, of any such order, judgment, claim or proof.

This indemnity constitutes a separate and independent obligation of the Issuer and shall give rise to a separate and independent cause of action.

## 20. Rounding

For the purposes of any calculations referred to in these Conditions (unless otherwise specified in these Conditions or the relevant Final Terms), (a) all percentages resulting from such calculations will be rounded, if necessary, to the nearest one hundred-thousandth of a percentage point (with 0.000005 per cent. being rounded up to 0.00001 per cent.), (b) all United States dollar amounts used in or resulting from such calculations will be rounded to the nearest cent (with one half cent being rounded up), (c) all Japanese Yen amounts used in or resulting from such calculations will be rounded downwards to the next lower whole Japanese Yen amount, and (d) all amounts denominated in any other currency used in or resulting from such calculations will be rounded to the nearest two decimal places in such currency, with 0.005 being rounded upwards.

## 21. Redenomination, Renominalisation and Reconventioning

- 21.1 *Application:* This Condition 21 (*Redenomination, Renominalisation and Reconventioning*) is applicable to the Notes only if it is specified in the relevant Final Terms as being applicable.
- 21.2 *Notice of redenomination:* If the country of the Specified Currency becomes or announces its intention to become, a Participating Member State, the Issuer may, without the consent of the Noteholders, on giving at least 30 days' prior notice to the Noteholders and the Paying Agent, designate a date (the "**Redenomination Date**"), being an Interest Payment Date under the Notes falling on or after the date on which such country becomes a Participating Member State.
- 21.3 *Redenomination:* Notwithstanding the other provisions of these Conditions, with effect from the Redenomination Date:
- (i) the Notes shall be deemed to be redenominated into Euro in the denomination of Euro 0.01 with a principal amount for each Note equal to the principal amount of that Note in the Specified Currency, converted into Euro at the rate for conversion of such currency into Euro established by the Council of the European Union pursuant to the Treaty (including compliance with rules relating to rounding in accordance with European Community regulations); *provided, however, that*, if the Issuer determines, with the agreement of the Principal Paying Agent then market practice in respect of the redenomination into Euro 0.01 of internationally offered securities is different from that specified above, such provisions shall be deemed to be amended so as to comply with such market practice and the Issuer shall promptly notify the Noteholders, each listing authority, stock exchange and/or quotation system (if any) by which the Notes have then been admitted to listing, trading and/or quotation and the Paying Agents of such deemed amendments;
  - (ii) all payments in respect of the Notes (other than, unless the Redenomination Date is on or after such date as the Specified Currency ceases to be a sub-division of the Euro, payments of interest

in respect of periods commencing before the Redenomination Date) will be made solely in Euro by credit or transfer to a Euro account (or any other account to which Euro may be credited or transferred) maintained by the payee with, a bank in the principal financial centre of any Member State of the European Communities.

21.4 *Interest Determination Date*: If the Floating Rate Note Provisions are specified in the relevant Final Terms as being applicable and Screen Rate Determination is specified in the relevant Final Terms as the manner in which the Rate(s) of Interest is/are to be determined, with effect from the Redenomination Date the Interest Determination date shall be deemed to be the second TARGET Settlement Day before the first day of the relevant Interest Period.

## **22. Governing Law and Jurisdiction**

22.1 *Governing law*: The Notes are governed by, and shall be construed in accordance with, the laws of the Republic of Italy.

22.2 *Jurisdiction*: The courts of Rome are to have exclusive jurisdiction to settle any dispute arising from or connected with the Notes.

Set out below is the form of Final Terms which will be completed for each Tranche of Notes issued under the Programme.

**[PROHIBITION OF SALES TO EEA RETAIL INVESTORS - The Notes are not intended to be offered, sold or otherwise made available to and should not be offered, sold or otherwise made available to any retail investor in the European Economic Area ("EEA"). For these purposes, a retail investor means a person who is one (or more) of: (i) a retail client as defined in point (11) of Article 4(1) of Directive 2014/65/EU (as amended, "MiFID II"); or (ii) a customer within the meaning of Directive 2002/92/EC (as amended or superseded), where that customer would not qualify as a professional client as defined in point (10) of Article 4(1) of MiFID II. Consequently, no key information document required by Regulation (EU) No 1286/2014 (as amended, the "PRIIPs Regulation") for offering or selling the Notes or otherwise making them available to retail investors in the EEA has been prepared and therefore offering or selling the Notes or otherwise making them available to any retail investor in the EEA may be unlawful under the PRIIPs Regulation.]<sup>3</sup>**

**MIFID II PRODUCT GOVERNANCE / PROFESSIONAL INVESTORS AND ECPS ONLY TARGET MARKET – Solely for the purposes of [the/each] manufacturer's product approval process, the target market assessment in respect of the Notes has led to the conclusion that: (i) the target market for the Notes is eligible counterparties and professional clients only, each as defined in Directive 2014/65/EU (as amended, "MiFID II"); and (ii) all channels for distribution of the Notes to eligible counterparties and professional clients are appropriate. [Consider any negative target market]. Any person subsequently offering, selling or recommending the Notes (a "distributor") should take into consideration the manufacturer['s/s'] target market assessment; however, a distributor subject to MiFID II is responsible for undertaking its own target market assessment in respect of the Notes (by either adopting or refining the manufacturer['s/s'] target market assessment) and determining appropriate distribution channels.**

**Final Terms dated [●]  
Cassa depositi e prestiti S.p.A.**

Issue of [Aggregate Nominal Amount of Tranche] [Title of Notes]

**under the Euro 10,000,000,000 Debt Issuance Programme**

## **PART A – CONTRACTUAL TERMS**

[Terms used herein shall be deemed to be defined as such for the purposes of the Terms and Conditions of the Notes (the "**Conditions**") set forth in the Base Prospectus dated 10 May 2019 [and the supplement[s] to the Base Prospectus dated [●] [and [●]] which [together] constitute[s] a base prospectus for the purposes of Article 5.4 of Directive 2003/71/EC (as amended or superseded) (the "**Prospectus Directive**"). This document constitutes the Final Terms of the Notes described

---

<sup>3</sup> [(to be inserted if the Notes may constitute "packaged" products and no KID will be prepared)].

herein for the purposes of Article 5.4 of the Prospectus Directive and must be read in conjunction with such Base Prospectus [as so supplemented].]

[Full information on the Issuer and the Notes described herein is only available on the basis of a combination of these Final Terms and the Base Prospectus [as so supplemented]. The Base Prospectus [and the Supplement[s] to the Base Prospectus] [is] [are] available for viewing on the website of CDP, *www.cdp.it*, as well as on the website of the Luxembourg Stock Exchange, *www.bourse.lu*. Copies may be obtained from the Issuer during normal business hours at [address].]

*[The following alternative language applies if the first tranche of an issue which is being increased was issued under a Base Prospectus with an earlier date]*

Terms used herein shall be deemed to be defined as such for the purposes of the Conditions (the "**Conditions**") set forth in the Base Prospectus dated 9 May 2018. This document constitutes the Final Terms of the Notes described herein for the purposes of Article 5.4 of the Prospectus Directive and must be read in conjunction with the Base Prospectus dated 10 May 2019 [and the supplement[s] to it dated [date] [and [date]] which [together] constitute[s] a base prospectus for the purposes of the Prospectus Directive (the "**Base Prospectus**"), including the Conditions incorporated by reference in the Base Prospectus.

Full information on the Issuer and the offer of the Notes is only available on the basis of the combination of these Final Terms and the Base Prospectus [as so supplemented]. The Base Prospectus [and the Supplement[s] to the Base Prospectus] [is] [are] available for viewing on the website of CDP *www.cdp.it*, as well as on the website of the Luxembourg Stock Exchange, *www.bourse.lu*. Copies may be obtained from the Issuer during normal business hours at [address]].

*[Include whichever of the following apply or specify as "Not Applicable" (N/A). Note that the numbering should remain as set out below, even if "Not Applicable" is indicated for individual paragraphs or sub-paragraphs. Italics denote guidance for completing the Final Terms.]*

1. [(i)] Series Number: [●]  
[(ii)] Tranche Number: [●]  
[(iii)] Date on which the Notes become fungible: [Not Applicable/ The Notes shall be consolidated, form a single series and be interchangeable for trading purposes with the with [Tranche [●]] of [Aggregate Nominal Amount of Tranche][Title of Notes] on [insert date/the Issue Date]
2. **Specified Currency** or [●]  
**Currencies:**
3. **Aggregate Nominal Amount of** [●]  
**Notes** [admitted to trading]:

- [(i)] Series: [•]
- [(ii)] Tranche: [•]
4. **Issue Price:** [•] per cent of the Aggregate Nominal Amount [plus accrued interest from *[insert date]* (if applicable)]
5. [(i)] Specified Denominations: [•]  
[•]  
*[Notes (including Notes denominated in Sterling) in respect of which the issue proceeds are to be accepted by the Issuer in the United Kingdom or whose issue otherwise constitutes a contravention of Section 19 of the FSMA and which have a maturity of less than one year must have a minimum redemption value of £100,000 (or its equivalent in other currencies)]*
- [(ii)] Calculation Amount: [•] *(If only one Specified Denomination, insert the Specified Denomination. If more than one Specified Denomination, insert the highest common factor. There must be a common factor in the case of two or more Specified Denominations.)*
6. [(i)] Issue Date: [•]
- [(ii)] Interest Commencement Date [•]
7. **Maturity Date:** *[Specify date or for Floating Rate Notes Interest Payment Date falling in or nearest to [specify month and year]]*
8. **Interest Basis:** [• per cent. Fixed Rate]  
[[EURIBOR]/[LIBOR] +/- • per cent. Floating Rate]  
[Zero Coupon]  
  
[Floating Rate: CMS Linked Interest Rate] (see paragraph [13/14/15] below)
9. **Change of Interest:** [Applicable]/[Not Applicable]  
  
*(Specify the date when any change from fixed to floating rate or vice versa occurs or cross refer to paragraphs 13 and 14*

*below and identify there)*

**10 Put/Call Options:**

[Investor Put]

[Issuer Call]

[(see paragraph [16/17] below)]

[Not Applicable]

**11 Partly Paid:**

[Applicable]/[Not Applicable]

[(see paragraph 23 below)]

**PROVISIONS RELATING TO INTEREST (IF ANY) PAYABLE**

**12 Fixed Rate Note Provisions**

[Applicable / Not Applicable]

*(If not applicable, delete the remaining sub-paragraphs of this paragraph)*

(i) Rate[(s)] of Interest: [●] per cent. per annum [payable [annually/semi-annually/quarterly/monthly] in arrear on each Interest Payment Date]

(ii) Interest Payment Date(s): [●] in each year up to, and including, the Maturity Date (*Amend appropriately in the case of irregular coupons*) [, adjusted in accordance with the Business Day Convention set out in (vii) below /not adjusted]

(iii) Fixed Coupon Amount[(s)]: [●] per Calculation Amount

(iv) Broken Amount(s): [[●] per Calculation Amount, payable on the Interest Payment Date falling [in/on] [●]]/[Not Applicable]

*(Insert particulars of any initial or final broken interest amounts which do not correspond with the Fixed Coupon Amount[(s)])*

(v) Day Count Fraction: [Actual/Actual (ICMA)] / [Actual/365] / [Actual/Actual (ISDA)] / [Actual/365 (Fixed)] / [Actual/360] / [30/360] / [30E/360] / [Eurobond Basis] / [30E/360 (ISDA)]

(vi) Determination Dates: [[●] in each year] [Not Applicable] (*insert regular interest payment dates, ignoring issue date or maturity date in the case of a long or short first or last coupon. N.B.*)



*only relevant where Day Count Fraction is Actual/Actual (ICMA))*

(vii) Business Day Convention: [Following Business Day Convention/ Modified Following Business Day Convention/ Preceding Business Day Convention/ Not Applicable]

13 **Floating Rate Note Provisions** [Applicable/Not Applicable]  
*(If not applicable, delete the remaining sub-paragraphs of this paragraph)*

(i) Interest Period(s) [●], subject to adjustment in accordance with the Business Day Convention set out in (iii) below/not adjusted]

(ii) Specified Interest Payment Dates: [●], subject to adjustment in accordance with the Business Day Convention set out in (iii) below/not adjusted]

(iii) Business Day Convention: [Floating Rate Convention/ Following Business Day Convention/ Modified Following Business Day Convention/ Preceding Business Day Convention] [Not Applicable]

(iv) Additional Business Centre(s): [Not Applicable]/ [●]

(v) Manner in which the Rate(s) of Interest is/are to be determined: [Screen Rate Determination/ISDA Determination]

(vi) Calculation Agent responsible for calculating the Rate(s) of Interest and Interest Amount(s): [●]

(vii) Screen Rate Determination:

● Reference Rate: [For example, LIBOR or EURIBOR]/[CMS Reference Rate/Leveraged CMS Reference Rate/Leveraged CMS Reference Rate 2/Steepner CMS Reference Rate: [Unleveraged/Leveraged]/Call CMS Reference Rate]

Reference Currency: [●]

Designated Maturity: [●]/[The CMS Rate having a Designated Maturity of [●] shall

be "CMS Rate 1" and the CMS Rate having a Designated Maturity of [●] shall be "CMS Rate 2"]

*(Where more than one CMS Rate, specify the Designated Maturity for each relevant CMS Rate)*

- Relevant Screen Page: [●]  
*(In the case of EURIBOR, if not Reuters EURIBOR01 ensure it is a page which shows a composite rate or amend the fallback provisions appropriately)*  
*(In the case of a CMS Linked Interest Note, specify relevant screen page and any applicable headings and captions)*
- Interest Date(s): Determination [●]  
*(In the case of a CMS Rate where the Reference Currency is euro): [Second day on which the TARGET2 system is open prior to the start of each Interest Period]*  
*(In the case of a CMS Rate where the Reference Currency is other than euro): [Second (specify type of day) prior to the start of each Interest Period]*
- Relevant Time: [For example, 11.00 a.m. London time/Brussels time]
- Relevant Financial Centre: [For example, London/Euro-zone (where Euro-zone means the region comprised of the countries whose lawful currency is the euro)]
- Cap: [[●] per cent. per annum]
- Floor: [[●] per cent. per annum]
- Leverage: [[●] per cent.]
- (viii) ISDA Determination:
  - Floating Rate Option: [●]
  - Designated Maturity: [●]

- Reset Date: [●]  
*(In the case of a LIBOR or EURIBOR based option, the first day of the Interest Period. In the case of a CMS Linked Interest Note, if based on euro then the first day of each Interest Period and if otherwise to be checked)*
- (ix) Margin(s): [+/-][ ] per cent per annum
- (x) Minimum Rate of Interest: [0] / [●] per cent per annum
- (xi) Maximum Rate of Interest: [●] per cent per annum
- (xii) Day Count Fraction: [Actual/Actual (ICMA)] / [Actual/365] / [Actual/Actual (ISDA)] / [Actual/365 (Fixed)] / [Actual/360] / [30/360] / [30E/360] / [Eurobond Basis] / [30E/360 (ISDA)]

**14 Zero Coupon Note Provisions** [Applicable/Not Applicable]  
*(If not applicable, delete the remaining sub-paragraphs of this paragraph)*

- (i) Accrual Yield: [●] per cent per annum
- (ii) Reference Price: [●]
- (iii) Day Count Fraction in relation to Early Redemption Amounts: [Actual/Actual (ICMA)] / [Actual/365] / [Actual/Actual (ISDA)] / [Actual/365 (Fixed)] / [Actual/360] / [30/360] / [30E/360] / [Eurobond Basis] / [30E/360 (ISDA)]

**PROVISIONS RELATING TO REDEMPTION**

**15 Call Option** [Applicable/Not Applicable]

*(If not applicable, delete the remaining sub-paragraphs of this paragraph)*

- (i) Optional Redemption Date(s) (Call): [●]
- (ii) Optional Redemption Amount(s) (Call): [●] per Calculation Amount
- (iii) If redeemable in part:
  - (a) Minimum Redemption [●] per Calculation Amount

Amount:

(b) Maximum Redemption [●] per Calculation Amount  
Amount:

(iv) Notice period: [●]

*(N.B. When setting notice periods, the Issuer is advised to consider the practicalities of distribution of information through intermediaries, for example, clearing systems and custodians, as well as any other notice requirements which may apply, for example, as between the Issuer and the Agent or the Representative of the Noteholders)*

**16 Put Option**

[Applicable/Not Applicable]

*(If not applicable, delete the remaining sub-paragraphs of this paragraph)*

(i) Optional Redemption [●]  
Date(s):

(ii) Optional Redemption [●] per Calculation Amount  
Amount(s):

(iii) Notice period: [●]

*(N.B. When setting notice periods, the Issuer is advised to consider the practicalities of distribution of information through intermediaries, for example, clearing systems and custodians, as well as any other notice requirements which may apply, for example, as between the Issuer and the Agent or Representative of the Noteholders)*

**17 Final Redemption Amount of each Note** The principal amount of each Note, being [●] per Calculation Amount

**18 Early Redemption Amount**

Early Redemption Amount(s) of each Note payable on redemption for taxation reasons or on event of default or other early redemption: [[Not Applicable] / [[●] per Calculation Amount]]

## GENERAL PROVISIONS APPLICABLE TO THE NOTES

- 19 **Financial Centre(s):** [Not Applicable/[•]]  
*Note that this item relates to the date and place of payment, and not the end dates of Interest Periods for the purposes of calculating the amount of interest]*
- 20 **Talons for future Coupons to be attached to Notes** (and dates on which such Talons mature): [Yes]/[No]
- 21 **Redenomination, renominatisation and reconventioning provisions:** [Not Applicable/The provisions [in Condition [•]] apply]
- 22 **Details relating to Partly Paid Notes** (amount of each payment comprising the Issue Price and date on which each payment is to be made and consequences (if any) of failure to pay, including any right of the Issuer to forfeit the Notes and interest due on late payment): [Not Applicable/[•]]  
*(N.B. Note that payments of the Issue Price in relation to Partly Paid Notes will be effected in a maximum of 10 instalments during a maximum period of 3 months from the Issue Date)*
- 23 **[Representative of the Noteholders]** [BNP Paribas Securities Services]/[•]]

Signed on behalf of the Issuer:

By: .....

Duly authorised

## PART B – OTHER INFORMATION

### 1. LISTING AND ADMISSION TO TRADING

- (i) Listing: [The Official List of Luxembourg Stock Exchange] / [●] / [None]
- (ii) Admission to trading: [Application has been made to be admitted to trading on the [●] [Regulated Market of the Luxembourg Stock Exchange] with effect from [●].] [Not Applicable.]
- (iii) Estimate of total expenses related to admission to trading: [●]

### 2. RATINGS

Ratings: The Notes to be issued have been rated:

[Fitch: [●]]

[Moody's: [●]]

[S & P: [●]]

[Scope: [●]]

[[Other]: [●]]

*(The above disclosure should reflect the rating allocated to Notes of the type being issued under the Programme generally or, where the issue has been specifically rated, that rating.)*

*[[Insert credit rating agency] is established in the European Union and has applied for registration under Regulation (EU) No 1060/2009 (as amended), although notification of the corresponding registration decision has not yet been provided by the relevant competent authority.]/ [[Insert credit rating agency] is established in the European Union and registered under Regulation (EU) No 1060/2009 (as amended) and is included in the list of registered credit rating agencies published on the website of the European Securities and Markets Authority at*

*http://www.esma.europa.eu/page/List-registered-and-certified-CRAs] / [[Insert credit rating agency] is not established in the European Union and has not applied for registration under Regulation (EU) No 1060/2009 (as amended).]*

*In general, European regulated investors are restricted from using a rating for regulatory purposes if such rating is not issued by a credit rating agency established in the European Union and registered under the Regulation (EU) No 1060/2009 (as amended) ("**CRA Regulation**") [(or is endorsed and published or distributed by subscription by such a credit rating agency in accordance with the CRA Regulation) unless (1) the rating is provided by a credit rating agency not established in the EEA but endorsed by a credit rating agency established in the EEA and registered under the CRA Regulation or (2) the rating is provided by a credit rating agency not established in the EEA which is certified under the CRA Regulation].*

**3. [INTERESTS OF NATURAL AND LEGAL PERSONS INVOLVED IN THE [ISSUE/OFFER]**

*[Need to include a description of any interest, including conflicting ones, that is material to the issue/offer, detailing the persons involved and the nature of the interest. May be satisfied by the inclusion of the statement below:]*

*"[Save for any fees payable to the [Managers/Dealers], so far as the Issuer is aware, no person involved in the issue of the Notes has an interest material to the offer. The [Managers/Dealers] and their affiliates have engaged, and may in the future engage, in investment banking and/or commercial banking transactions with, and may perform other services for, the Issuer and its affiliates in the ordinary course of business. (Amend as appropriate if there are other interests)"]*

**4. REASONS FOR THE OFFER, ESTIMATED NET PROCEEDS AND TOTAL EXPENSES (*Green Bonds, Social Bonds or Sustainability Bonds only*)**

|                            |  |
|----------------------------|--|
| [(i) Reasons for the offer | [●] [Not Applicable](If the Notes are Green Bonds, Social Bonds or Sustainability Bonds describe the relevant projects to which the net proceeds of the Tranche of Notes will be applied or make reference to the relevant |
|----------------------------|--|

*bond framework to which the net proceeds of the Tranche of Notes will be applied.)*

*(Applicable only in the case of securities to be classified as Green Bonds, Social Bonds or Sustainability Bonds. If not applicable, delete this paragraph.)*

[(ii)] Estimated net proceeds: [●] [Not Applicable]

[(iii)] Estimated total expenses: [●] [*Include breakdown of expenses.*] [Not Applicable]

*(Only necessary to include disclosure of net proceeds and total expenses at (ii) and (iii) above where disclosure is not included at (i) above.)*

## 5. **YIELD (*Fixed Rate Notes only*)**

Indication of yield: [●] / [Not Applicable]

## 6. **HISTORIC INTEREST RATE (*Floating Rate Notes only*)**

Details of historic [LIBOR/EURIBOR] rates can be obtained from [Reuters]. / [Not Applicable]

## 7. **OPERATIONAL INFORMATION**

ISIN Code: [●]

Common Code: [●]

[CFI Code: [[See] / [*insert code*], as updated, as set out on]] the website of the Association of National Numbering Agencies (ANNA) or alternatively sourced from the responsible National Numbering Agency that assigned the ISIN / Not Applicable / Not Available]

[FISN: [[See] / [*insert code*], as updated, as set out on]] the website of the Association of National Numbering Agencies (ANNA) or alternatively sourced from the responsible National Numbering Agency that assigned the ISIN / Not Applicable / Not Available]

Any clearing system(s) other than Monte Titoli, Euroclear Bank [Not Applicable/*give name(s) and number(s)*]



S.A./N.V. and Clearstream Banking Société Anonyme and the relevant identification number(s) and addresses:

Delivery: Delivery [against/free of] payment

Names and addresses of additional Paying Agent(s) (if any): [●]

## 8. DISTRIBUTION

(i) Method of distribution: [Syndicated/Non-syndicated]

(ii) If syndicated, names and addresses of Dealers and underwriting commitments: [Not Applicable/give names, addresses and underwriting commitments]

*(Include names and addresses of entities agreeing to underwrite the issue on a firm commitment basis and names and addresses of the entities agreeing to place the issue without a firm commitment or on a "best efforts" basis if such entities are not the same as the Dealers.)*

(iii) Date of [Subscription] Agreement: [●] [Not Applicable]

(iv) Stabilising Manager(s) (if any): [Not Applicable/ give name]

(v) If non-syndicated, name and address of Dealer: [Not Applicable/ give name and address]

(vi) U.S. Selling restriction: [Reg. S Compliance Category [1/2/3]; TEFRA Not Applicable]

## 9. CORPORATE AUTHORISATIONS

[Date] [Board] approval for issuance of Notes obtained: [●] [registered with the Companies' Registry of [Rome] on [●] [and [●], respectively] [Not Applicable]

*(N.B Only relevant where Board (or similar) authorisation is required for the particular tranche of Notes)*

## 10. PROHIBITION OF SALES TO EEA RETAIL INVESTORS

[Applicable] / [Not Applicable]

*(If the Notes clearly do not constitute "packaged" products, "Not Applicable" should be specified. If the Notes may constitute "packaged" products and no KID will be prepared, "Applicable" should be specified.)*

## 11. BENCHMARK

- (i) EU Benchmarks Regulation: [Applicable: Amounts payable under the Notes are calculated by reference to [EURIBOR] [LIBOR] [*insert name[s] of benchmark(s)*], which [is/are] provided by [European Money Markets Institute] [ICE Benchmark Administration Limited] [*insert name[s] of the administrator[s]*] – *if more than one specify in relation to each relevant benchmark*].
- (ii) EU Benchmarks Regulation: Article 29(2) statement on benchmarks: As at the date hereof, [European Money Markets Institute] [ICE Benchmark Administration Limited] [*Benchmark administrator*] [appears] / [does not appear] on the register of administrators and benchmarks established and maintained by the European Securities and Markets Authority pursuant to article 36 of the Benchmarks Regulation (Regulation (EU) 2016/1011 (the "**Benchmarks Regulation**"). [As far as the Issuer is aware, *EITHER* [European Money Markets Institute] [ICE Benchmark Administration Limited] [*Benchmark administrator*] does not fall within the scope of the Benchmarks Regulation] OR [the transitional provisions in Article 51 of the Benchmarks Regulation apply, such that [European Money Markets Institute] [ICE Benchmark Administration Limited] [*Benchmark administrator*] is not currently required to obtain authorisation/registration (or, if located outside the European Union, recognition, endorsement or equivalence)].]

## DESCRIPTION OF CASSA DEPOSITI E PRESTITI S.P.A.

### INTRODUCTION

Cassa depositi e prestiti società per azioni ("**CDP**" or the "**Issuer**") is a joint stock company (*società per azioni*) incorporated on 12 December 2003 under the laws of the Republic of Italy. The registered office of CDP and its principal place of business is Via Goito 4, Rome, Italy, telephone number +39 06 42211. CDP is enrolled in the Register of Companies of Rome with registration number and fiscal code 80199230584.

CDP's shares are not listed on any stock exchange. The long-term unsecured, unsubordinated and unguaranteed debt obligations of CDP are rated BBB by Fitch Ratings, Baa3 by Moody's, BBB by S&P and BBB+ by Scope. A long-term, unsecured, unsubordinated and unguaranteed debt securities rating of: (i) 'BBB' by Fitch Ratings indicates that expectations of default risk are currently low and that the capacity for payment of financial commitments is considered adequate but adverse business or economic conditions are more likely to impair this capacity; (ii) 'Baa' by Moody's indicates that the issuer's debt securities are subject to moderate credit risk - they are considered medium grade and as such may possess certain speculative characteristics. The modifier "3" indicates a ranking in the lower end of that generic rating category; (iii) 'BBB' by S&P indicates that the Issuer debt securities exhibit adequate protection parameters; however, adverse economic conditions or changing circumstances are more likely to weaken the issuer's capacity to meet its financial commitments with respect to its debt securities; and (iv) "BBB+" by Scope reflects an opinion of good credit quality. Each of Fitch Ratings, Moody's S&P and Scope is established in the EEA and registered under the CRA Regulation, and is included in the list of registered credit rating agencies published on the website of the European Securities and Markets Authority at <http://www.esma.europa.eu/page/List-registered-and-certified-CRAs>.

Whether or not each credit rating applied for in relation to the relevant Series of Notes will be issued by a credit rating agency established in the European Union and registered under the CRA Regulation will be disclosed in the Final Terms. In general, European-regulated investors are restricted from using a rating for regulatory purposes if such rating is not issued by a credit rating agency established in the European Union and registered under the CRA Regulation (or is endorsed and published or distributed by subscription by such a credit rating agency in accordance with the CRA Regulation) unless the rating is provided by a credit rating agency operating in the European Union before 7 June 2010 which has submitted an application for registration in accordance with the CRA Regulation and such registration is not refused.

### HISTORY

CDP is the company resulting from the transformation of the Cassa depositi e prestiti – a national public body (*amministrazione dello Stato*) - into joint stock companies, pursuant to Law Decree No. 269 of 30 September 2003 ("**Law Decree 269**"). Law No. 1270 of 17 May 1863 originally established Cassa depositi e prestiti through the merger of several financial institutions into the Public Debt General Department (*Direzione Generale del Debito Pubblico*). As such, for approximately one century,

Cassa depositi e prestiti was a general department of the Ministry of Treasury of the Republic of Italy. However, Cassa depositi e prestiti maintained its financial and accounting autonomy from the Italian State. Pursuant to Law No. 197 of 13 May 1983 ("**Law 197**"), the General Department was abolished and Cassa depositi e prestiti was set up as an independent administration (*amministrazione autonoma*). Legislative Decree No. 284 of 30 July 1999 reformed Cassa depositi e prestiti and classified it as a national public body (*amministrazione dello Stato*) with legal status and regulatory, organisational, economic and accounting autonomy.

Pursuant to Article 5, paragraph 1, of Law Decree 269, Cassa depositi e prestiti was transformed and incorporated, as of 12 December 2003, as a joint stock company under the name "*Cassa depositi e prestiti società per azioni*" and all assets, liabilities, rights and obligations previously owned by or owed to Cassa depositi e prestiti were transferred to CDP, with the exception of certain assets and liabilities which were transferred to the MEF, in accordance with the provisions of Article 5.

The duration of CDP, pursuant to article 4 of CDP's by-laws, is set until 31 December 2100, unless otherwise extended by shareholders' resolution. In 2015, CDP was appointed as a National Promotional Bank (*Istituto Nazionale di Promozione*) by the Italian government, pursuant to Article 1, paragraph 826 of Law No. 208 of 28 December 2015 (the "**Stability Law 2016**") and applicable EU legislation.

## REGULATION

CDP operates in accordance with Italian law and in particular is mainly regulated by the following laws and regulatory provisions:

- (i) Article 5 of Law Decree 269 setting out, *inter alia*, (a) the corporate purpose of CDP, (b) the structure of its financial management strategy, and (c) the special powers vested in the MEF in respect of CDP;
- (ii) the provisions of Title V of the Legislative Decree No. 385 of 1 September 1993 as amended (the "**Banking Act**") as set out for intermediaries registered in the register established under Article 106 of the Banking Act, taking into consideration the characteristics of CDP and the special regulation of the Separate Account System;
- (iii) the provisions of the Italian Civil Code applicable to Italian companies, to the extent and in relation to aspects that are not regulated by special provisions regarding CDP; and
- (iv) the decrees of the MEF regarding, *inter alia*, CDP's share capital, its shareholdings, the special powers assigned to CDP, the latter's assets and liabilities and its business activities (including without limitation, the ministerial decrees respectively dated 5 December 2003, 18 June 2004, 6 October 2004, 27 January 2005, 12 March 2009, 22 January 2010, 3 May 2011 and 12 April 2016).

CDP is the main shareholder of certain major Italian companies operating in Italy and abroad. The following chart shows the structure of CDP's holdings as of 31 December 2018:

## cassa depositi e prestiti

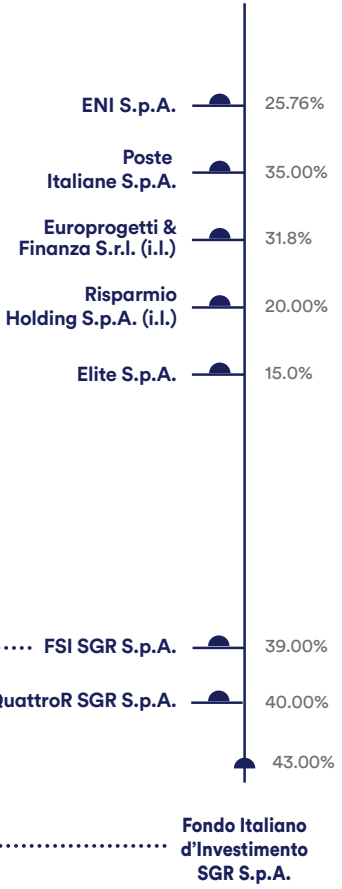

## OTHER EQUITY INVESTMENTS

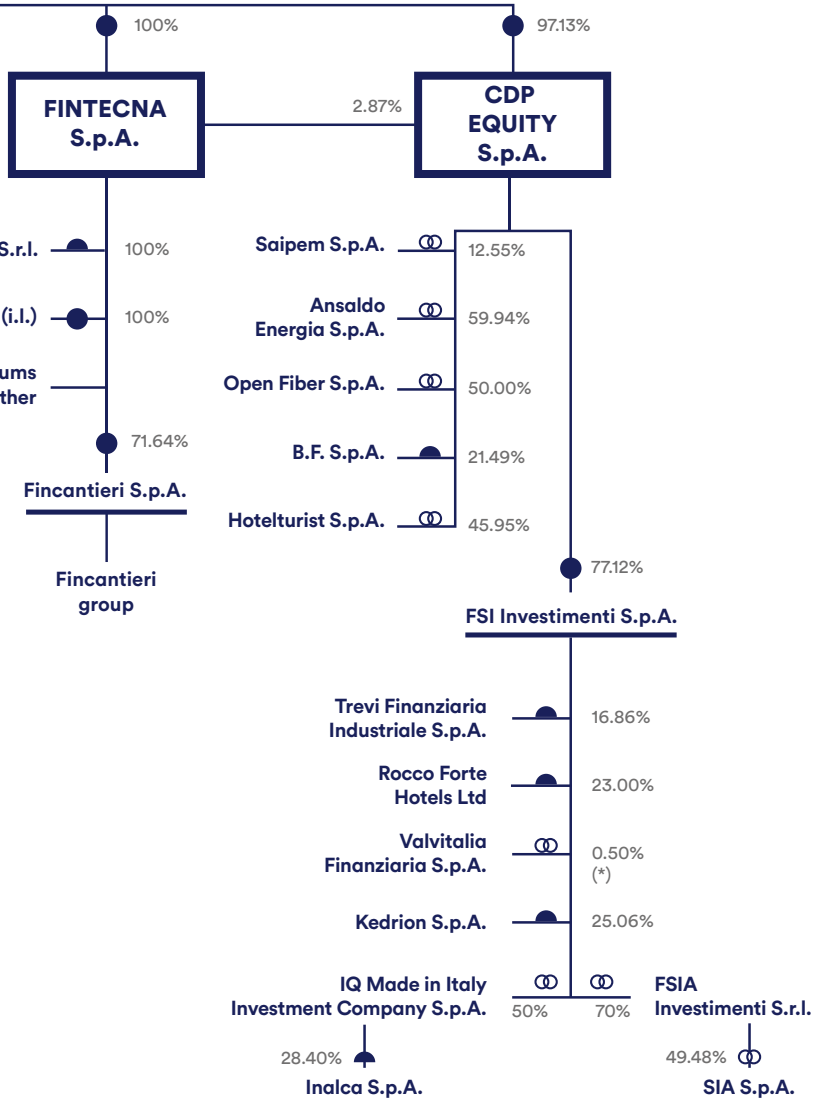
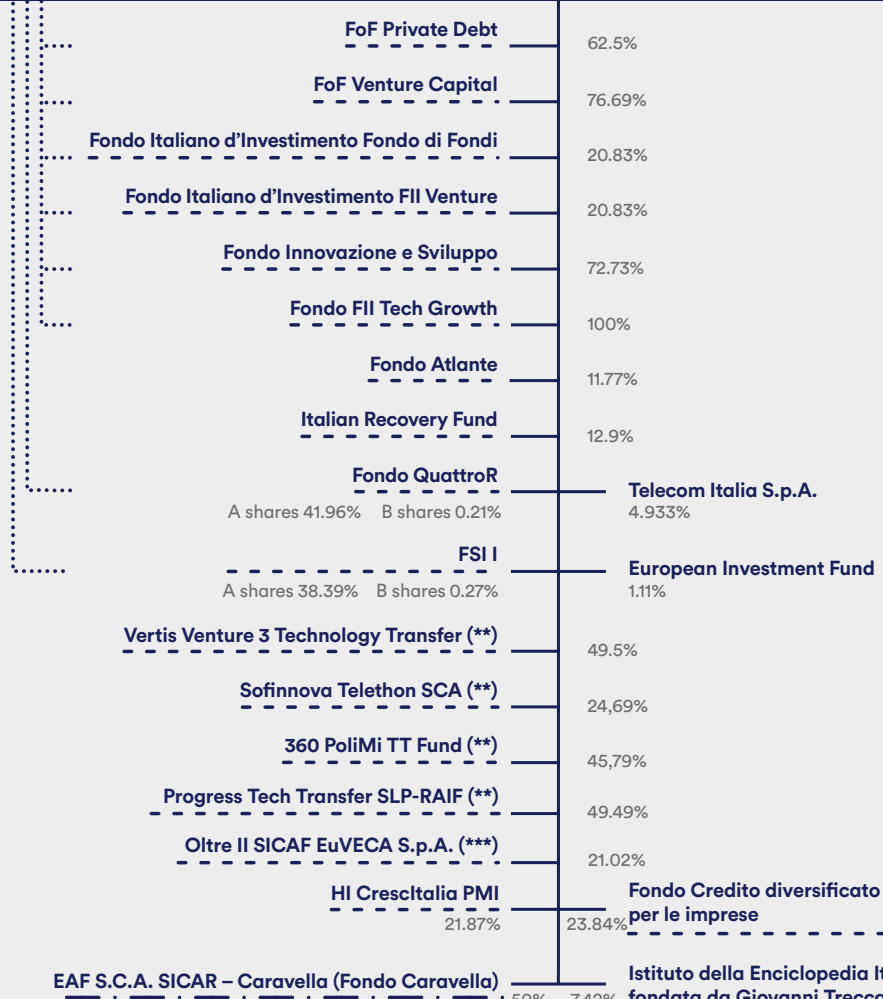

## LEGEND

**Business sectors**

- ENTERPRISES
- REAL ESTATE
- INTERNATIONAL EXPANSION
- INFRASTRUCTURE

**Type of control/influence**

- CONTROL
- DE FACTO CONTROL
- SIGNIFICANT INFLUENCE
- JOINT CONTROL
- INVESTMENT FUNDS
- INVESTMENT VEHICLES
- FUNDS MANAGEMENT RELATIONSHIP

*i.l.: in liquidazione*

(\*) 49.5% pro forma post convertible bond conversion.  
 (\*\*) Fund launched under the ITAtch investment platform; management and co-investment agreement signed by CDP and EIF focused on technology transfer funds.  
 (\*\*\*) Fund launched under the Social Impact Italia platform; management and co-investment agreement signed by CDP and EIF focused on social impact investing.

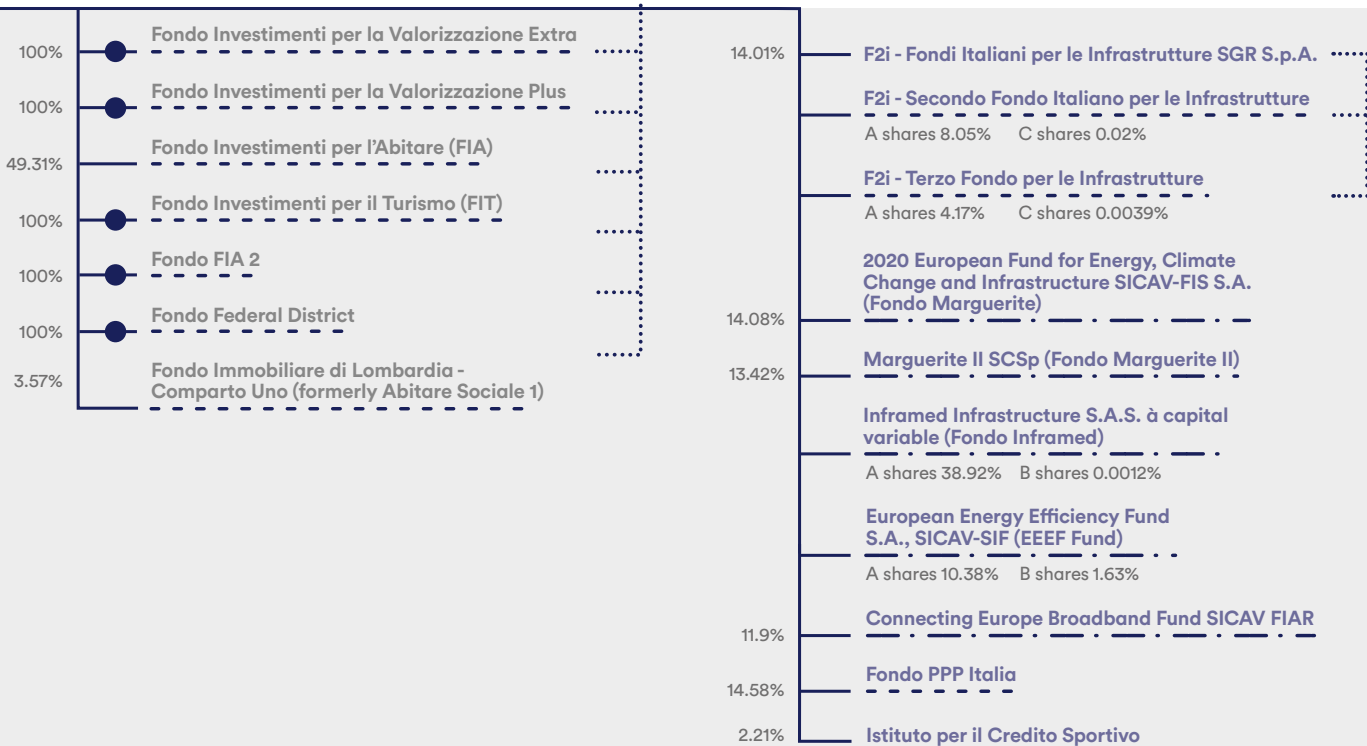
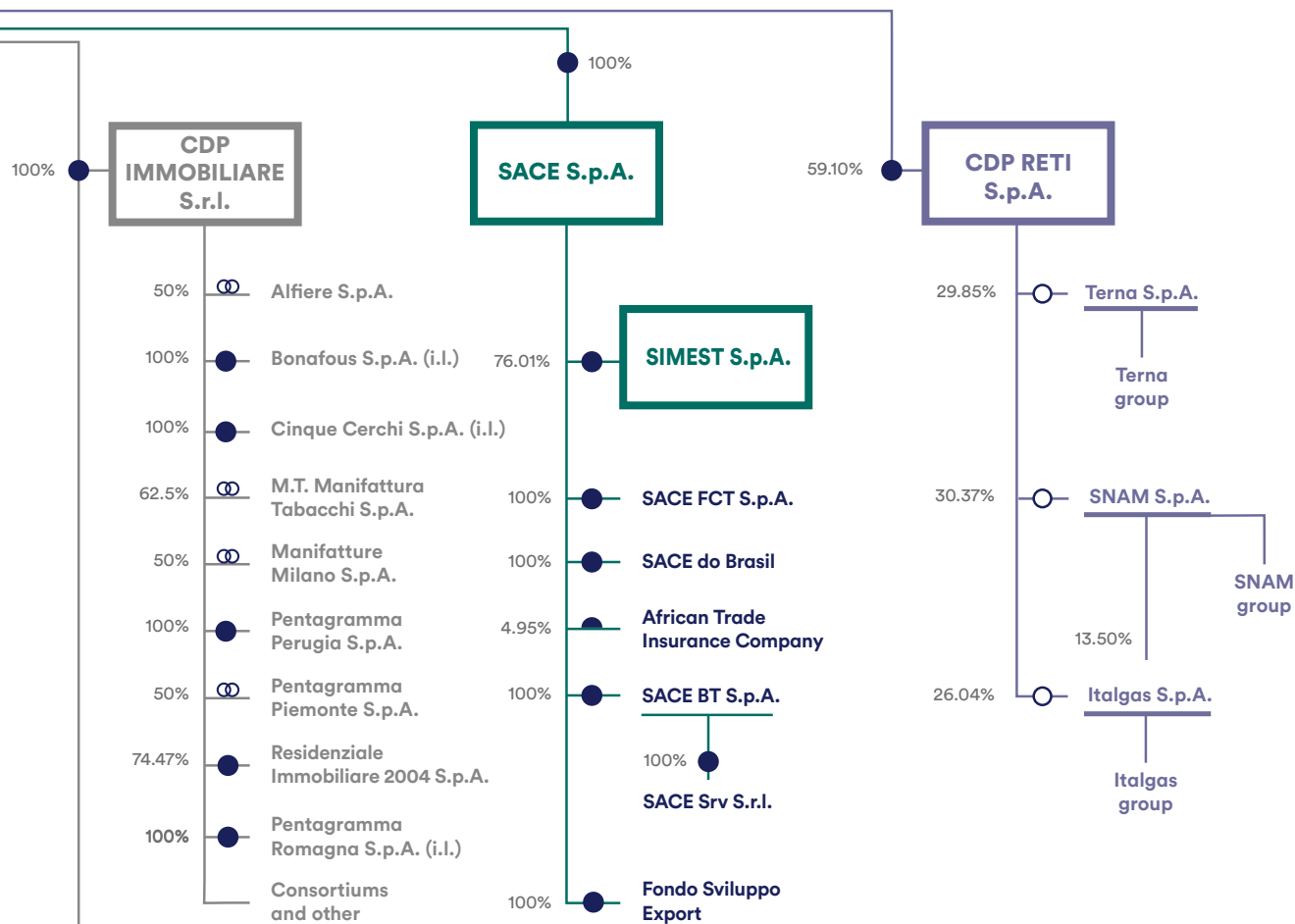

## BUSINESS OVERVIEW

### MAIN CORPORATE ACTIVITIES

Pursuant to paragraph 7 of Article 5 of Law Decree 269, as recently amended, and pursuant to article 3 of CDP's by-laws, as amended in order to reflect recent legislation, CDP's corporate purpose is the carrying out of the following activities:

- (A1) the granting of financing to the Italian State, its regions, local authorities, public entities and public law bodies (hereinafter, the "**Public Entities**");
- (A2) the granting of financing:
  - (i) in favour of public or private entities, with the exclusion of natural persons, having legal personality, for public-interest initiatives promoted by Public Entities, in accordance with the criteria established in decrees of the MEF adopted pursuant to Article 5, paragraph 11, letter (e);
  - (ii) in favour of private entities, with the exclusion of natural persons, having legal personality, for operations in the sectors of general interest specified in the decrees of the MEF adopted pursuant to Article 5, paragraph 11, letter (e);
  - (iii) in favour of public or private entities, with the exclusion of natural persons, having legal personality, to support the international expansion of enterprises and exports in accordance with the criteria established in decrees of the MEF adopted pursuant to Article 8 of Law Decree No. 78 of 1 July 2009, as converted into law ("**Law Decree 78**"), ratified with amendments by Law Decree No. 102 of 3 August 2009;
  - (iv) in favour of enterprises for the purposes of supporting the economy through (a) the banking system or (b) the subscription of units in investment funds managed by an asset management company, whose corporate purpose achieves one of the institutional missions of CDP;
  - (v) in favour of public or private entities, with the exclusion of natural persons, having legal personality, for international development cooperation activities; and
  - (vi) to banks operating in Italy to permit them to grant loans secured by mortgages on residential properties mainly for the purchase of primary residences or for renovation and energy efficiency enhancement works;
- (B) the granting of financing, preferably co-financed with banks, for:
  - (i) works, systems, networks and infrastructure to be used for the public interest;

- (ii) investments in research, development, innovation, the protection and leveraging of cultural assets, the promotion of tourism, environment, energy efficiency, promotion of sustainable development, the green economy; and
  - (iii) initiatives for company growth, including through business combination, in Italy and abroad;
- (C) the acquisition of shareholdings transferred to or conferred on CDP by the decree of the MEF referred to in Article 5, paragraph 3, letter (b), whose management is in line, where provided, with the criteria set out in the decree of the MEF referred to in Article 5, paragraph 11, letter (d);
- (D) the direct or indirect acquisition of equity investments in companies of major national interest - having a stable financial position and performance and adequate profit-generating prospects - that meet the requirements established by the MEF in the decree issued pursuant to Article 5, paragraph 8-*bis*.
- (E) the purchase of:
  - (iv) bank bonds backed by portfolios of loans secured by mortgages on residential properties and/or securities issued pursuant to the provisions of Law No. 130 of 30 April 1999 ("**Italian Securitisation Law**") as part of securitisations of claims in respect of loans secured by mortgages on residential properties;
  - (v) securities issued pursuant to the Italian Securitisation Law as part of securitisations of loans to small and medium-sized enterprises, with a view to expanding the volume of lending to small and medium-sized enterprises.
- (F) the management, possibly assigned by the MEF, of CDP's functions, assets and liabilities, outstanding prior to the transformation, which are transferred to the MEF pursuant to Article 5, paragraph 3, letter (a), as well as the management of any other public function and activity of general interest assigned as a consequence of any laws, regulations or agreements;
- (G) the supply of assistance and consultancy services in favour of Public Entities or to support the operations or the entities referred to in letter (A2) points (i), (ii), (iii), (iv) and (v);
- (H) the supply of consultancy services and study, research and analytical activities in the economic and financial fields.

In order to pursue its corporate purpose, the Issuer may also:

- (i) carry out any instrumental, connected and ancillary transactions, including commercial, industrial, mortgage, movable and real property, financial, lending and borrowing transactions;



- (ii) acquire shareholdings and interests in companies, undertakings, consortia and joint ventures, both in Italy and abroad, pursuant to the decree of the MEF dated 27 January 2005;
- (iii) coordinate the participating companies and the subsidiaries from an administrative and financial perspective, and carry out any necessary transaction in their favour, including the granting of loans;
- (iv) grant both *in personam* and *in rem* guarantees with respect to its own and third parties' obligations;
- (v) enter into financial derivatives transactions on its own account; and
- (vi) enter into financial derivatives transactions, also for purposes other than hedging.

Any sort of financing activity, including that conducted indirectly, is carried out in compliance with any applicable laws and it includes, *inter alia*, the purchase of receivables, the issue of guarantees, the acquisition of equity or debt securities and the subscription of units or shares of undertakings for collective investment. Unless otherwise provided by law, the financial transactions referred to in letter (A2) may be carried out directly if the amount is equal to or greater than Euro 25,000,000.00 (twenty-five million/00).

In order to pursue the corporate purpose indicated in letters (A1), (A2), (C), (F) and (G) above, CDP uses funds redeemable by way of passbook savings accounts and postal savings bonds, guaranteed by the Italian State and placed by Poste or its subsidiaries, and funds deriving from the issue of securities, the entering into loans and other financial transactions, which may be guaranteed by the State. These funds may also be used to pursue the purposes indicated in letters (D), (E) and (H) above.

In order to pursue the corporate purpose indicated in letter (B) above, CDP uses funds raised on the capital markets or from banks, deriving from its entry into loans, the issue of securities, other financial transactions or by means of loans granted by public or private entities or by international organisations or by means of any other resource of the Issuer and income consistent with the Issuer's corporate purpose, in any case without a guarantee granted by the state and without first-hand fund-raising. These funds may also be used to pursue the purposes indicated in letters (D), (E) and (H) above.

Pursuant to paragraph 20 of Article 5 of Law Decree 269, CDP's fund-raising activities are not subject to (i) the restrictions of Article 11 of the Banking Act on fund-raising with the public (save for the exclusion of demand deposits and the requirement of placements to and borrowings from institutional investors only, described under paragraph (b) above), or (ii) the maximum thresholds established by Italian laws for bond issuances by joint stock companies and more generally the provisions of the Italian Civil Code on the issuance of bonds.

In connection with any issue of financial instruments by CDP, a representative of the noteholders may be appointed to act on behalf of the noteholders, to exercise the powers vested in it and to approve certain amendments or modifications to the terms and conditions of the relevant transaction.

All interest and other income payable in respect of the financial instruments issued by CDP are subject to the provisions of Legislative Decree No. 239, regardless of their terms and maturity.

## **LENDING**

In 2018, CDP provided Euro 16.6 billion in new lending, investments and managed resources mainly consisting of loans to enterprises to support growth and exports and loans to the infrastructure sector.

Specifically, volume of new lending, investments and managed resources in 2018 is mainly related to:

- (i) lending mainly for investments by Regions in local development and projects in the transport sector (totalling an amount equal to Euro 5.5 billion, or 33 per cent. of the total amount of managed resources), (see "*A. Public Entities and Infrastructure*" below);
- (ii) lending to support the international expansion of Italian enterprises (totalling an amount equal to Euro 4.5 billion, or 27 per cent. of the total amount of managed resources), (see "*B. Export credit and internationalisation (internazionalizzazione)*" below);
- (iii) initiatives to support areas affected by natural disasters and transactions in favour of enterprises including through new forms of facilities such as risk sharing/capital relief (totalling an amount equal to Euro 6.5 billion, or 39 per cent. of the total amount of managed resources), (see "*C. Financing in support of enterprises and other entities*" below); and
- (iv) investments in real estate sector, targeting in particular social housing and tourism projects (totalling an amount equal to Euro 0.1 billion, or 1 per cent. of the total amount of managed resources), (see "*D. Real Estate*" below).

### *A. Public Entities and Infrastructures*

#### *A.1 Financing of Public Entities*

CDP carries out the traditional activity of financing Public Entities using funds pursuant to Article 5, paragraph 7, letter (a) of Law Decree 269.

By way of Ministerial Decree of 6 October 2004 (*Determinazioni ai sensi dell'art. 5, comma 11, lettere a), b) e c), del D.L. 30 settembre 2003, n. 269 convertito con modificazioni dalla legge 24 novembre 2003, n. 326 ed esercizio del potere di indirizzo della gestione separata della Cassa depositi e prestiti, società per azioni, a norma dell'art. 5, comma 9, del citato decreto-legge*), the MEF has set forth, *inter alia*, the criteria applying to CDP's financing of Public Entities, pursuant to which:

- (i) such financing activity carried out by CDP constitutes a service of general economic interest;
- (ii) the relevant loans shall be granted by CDP as specific purpose loans (*prestiti di scopo*), which may be utilised by Public Entities in connection with the

carrying out of public interest investments or in connection with other purposes for which the relevant borrowers may incur indebtedness;

- (iii) the process carried out by CDP for the granting of specific purpose loans is aimed at ascertaining whether the relevant borrower fulfils the requirements set forth by applicable legislation (including, *inter alia*, compliance with the debt ratios provided from time to time by law);
- (iv) in carrying out such financing activity, CDP must ensure that each public borrower is granted, amongst its peers, free access, as well as equal and non-discriminatory contractual treatment; therefore the general terms and conditions applicable to such loans are notified by CDP through regulations (*circolari*) published in the Official Gazette and made available on the website of CDP;
- (v) such loans may be granted on a fixed or floating rate basis and the relevant interest rate is predetermined (currently on a weekly basis) and disclosed by way of publication on the website of CDP and in at least one daily newspaper;
- (vi) the financial equivalent of the interest rates applicable to the above-mentioned specific purpose loans shall not exceed, upon calculation at the relevant computation date, the interest rate referred to in Article 45, paragraph 32, of Law No. 448 of 23 December 1998 (*Misure di finanza pubblica per la stabilizzazione e lo sviluppo*) as subsequently amended, in relation to loans with repayment obligations on the part of the Republic of Italy (i.e. the interest rate determined from time to time by the MEF on the basis of the market conditions by way of specific notices to be published in the Official Gazette);
- (vii) such loans shall be granted by way of a written contract (which may fail to be entered into as a notarised deed (*atto in forma pubblica*)), a copy of which shall be provided to the borrower together with the general terms and conditions applicable thereto;
- (viii) in compliance with the provisions of paragraph 24 of Article 5 of Law Decree 269, any and all acts, deeds, agreements, assignments, performances and/or other formalities relating to specific purpose loans, their relevant performance, amendments or modifications and termination shall be exempt from registration tax (*imposta di registro*), stamp duty (*imposta di bollo*), mortgage and cadastral taxes (*imposte ipotecarie e catastali*) and from any other indirect tax or other charge, levy, impost or duty; and
- (ix) CDP may grant loans to Public Entities having characteristics other than those referred to in points (ii) to (vii) above, provided that such other loans are granted to the Public Entities and are destined to be used in connection with measures satisfying a public interest. The characteristics of such loans are set forth by CDP taking into account their specific purpose, the features of the investment to be made by the relevant borrower and the characteristics of the borrower.

In addition to the above, Italian Law No. 205 of 27 December 2017 authorises CDP to provide cash advances to small municipalities (5,000 residents at the most) as

part of the treasury services performed by Poste Italiane S.p.A. CDP and Poste Italiane S.p.A. signed a specific agreement in May 2018 in order to begin operations.

As at 31 December 2018, the stock of loans totalled Euro 74.2 billion<sup>4</sup>, including adjustments for IFRS purposes, decreasing from the end of 2017 (Euro 76.3 billion). The decline can be attributed to the amount of debt repaid during the period, which more than offset the disbursements of loans. Including commitments to disburse funds, the total stock amounted to Euro 78.3 billion, a 3 per cent. decrease from 31 December 2017 (Euro 81 billion). The change can be attributed to the fact that the volume of new lending was lower than principal repayments falling due at 31 December 2018.

New lending in 2018 included new loans for an amount equal to Euro 2.4 billion. More specifically, the increase in volume at the end of 2018 is mainly due to the increase (Euro 0.1 billion) of the loans with repayment charged to Local authorities.

The credit quality of the Public Entities area loan portfolio showed virtually no problem areas.

## *A.2. Infrastructure*

The Infrastructure Department is in charge of the financing, in any form, under the Ordinary Account System and the Separate Account System in accordance with regulations and CDP by-laws, in favour of national private and public counterparts in the following sectors: construction and public works (general contractors, plants), social infrastructure (schools, hospitals, prisons, car parks), transport (highways, railways, local public transport, ports, airports), energy and utilities (conventional power, renewable energy, electrical transmission networks, gas supply/transport/distribution/storage, LNG, energy efficiency), environment (water services and waste) and telecommunications (broadband, towers and infrastructure communication systems, data centres, satellites). In addition, the Infrastructure Department promotes the implementation and financing of infrastructure projects through assistance and advice to the public administration.

At 31 December 2018, the stock of loans, including IFRS adjustments, totalled Euro 6.5 billion, with a decrease compared to the figure recorded at the end of 2017 due to a higher volume of principal repayments and terminations of outstanding loans than the new disbursements for the year. As at the same date, loans, including commitments to lend, totalled Euro 12.2 billion, with a decrease of approximately 9% compared to the end of 2017.

---

<sup>4</sup> Loans to customers and banks of Financing of Public Entities (Euro 74.2 billion), Infrastructure (Euro 6.5 billion), Enterprises and Financial Institutions (Euro 15.3 billion), International Financing (Euro 4.9 billion), Equity investment loans (Euro 0.3 billion) included items 60 and 70 of balance sheet – asset, net of liquidity (Euro 167.9 billion), securities (Euro 48.7 billion) and other assets (Euro 5.6 billion).

Financing of transactions promoted by Public Entities and transactions related to general interest areas

Pursuant to Article 3, letter (A2) of CDP's by-laws, funds under Article 5, paragraph 7, letter (a) of Law Decree 269 can be used by CDP not only to finance Public Entities but also to finance, *inter alia*:

- (x) transactions of public interest promoted by such Public Entities in accordance with the criteria established by the MEF decree of 12 March 2009; and
- (xi) transactions of public interest related to areas of general interest identified by the MEF decree of 12 April 2016,

upon satisfactory assessment of the economic and financial feasibility of each such transaction.

With regard to the transactions of public interest promoted by Public Entities, the MEF decree of 12 March 2009 provides the following:

- (a) the criteria for identifying the transactions promoted by the Public Entities which may be financed under Article 5, paragraph 7, letter (a) of Law Decree 269, and which includes the following:
  - (vi) transactions which benefit from long-term public or European grants or other forms of public incentives for the realisation of investments or supplies of national interest;
  - (vii) transactions to be carried out in the context of a public concession;
  - (viii) transactions carried out in execution of agreements between the Public Entities and (x) third party countries or (y) European Union institutions or Member States;
  - (ix) transactions carried out within the framework of a public-private partnership;
  - (x) transactions which form part of the plans or other programming instruments of the Public Entities;
  - (xi) transactions which are co-financed by the EIB;
  - (xii) transactions aimed at fulfilling Public Entities' institutional role;
- (b) that the beneficiaries of the financing under Article 5, paragraph 7, letter (a) of Law Decree 269 may be public or private entities, with the exclusion of natural persons, and
- (c) that CDP shall provide funding for the above-mentioned transactions under Article 5, paragraph 7, letter (a) of Law Decree 269 on the basis of the creditworthiness of the prospective borrower and of the economic and financial sustainability of the relevant transaction.

As a general principle, funds provided by CDP with reference to the transactions mentioned above should not exceed 50 per cent. of the relevant investment.

With regard to the transactions of public interest related to areas of general interest, the MEF decree of 12 April 2016 provides the following:

- (d) the areas of general interest in which CDP can carry out transactions of public interest towards private entities, under Article 5, paragraph 7, letter (a) of Law Decree 269, are:
  - (i) environment and energy;
  - (ii) communications and digital;
  - (iii) infrastructure, transport and construction;
  - (iv) insurance and financial intermediation aimed at savings protection and credit access;
  - (v) research, innovation, education and training;
  - (vi) public services and health;
  - (vii) tourism and hospitality, also through the real estate assets promotion and management;
  - (viii) cultural heritage promotion and management;
  - (ix) areas which benefit from national and European public funds; and
  - (x) areas which operate plants or productive settlements recognised as strategic interest, as well as companies of relevant national interest.
- (e) the public interest transactions related to the above-mentioned areas are carried out:
  - (i) on the basis of the economic and financial sustainability and on the basis of the respective public interest; and
  - (ii) preferentially with the joint participation of other market players.

CDP's by-laws provide that the financing of transactions promoted by Public Entities or carried out in general interest areas, using funds under Article 5, paragraph 7, letter (a) of Law Decree 269, must comply with the following requirements, the financing (i) may be conducted either directly by CDP or through the banking system, provided that the financial transactions conducted directly by CDP must involve an amount equal to or greater than Euro 25,000,000 (twenty-five million), (ii) may be carried out in favour of public or private entities having legal personality, with the exclusion of natural persons, (iii) must fall under the Separate Account System which is based on transparency and economic equilibrium criteria and (iv) requires the assessment of the economic and financial sustainability of each project.

## Financing of public interest transactions

Pursuant to article 3, letter (B) of CDP's by-laws, CDP also carries out the financing, in any form, of works, systems, networks and infrastructure to be used for public interest and of investments in research, development, innovation, the protection and promotion of cultural heritage, the promotion of tourism, environment and energy efficiency promotion of sustainable development, the green economy, initiatives for company growth, including through business combination, in Italy and abroad.

These activities are carried out through funds raised from investors - only by means of the issuance of notes, borrowings and other financial transactions - or through public or private grants or grants provided by international organisations, in any case without a guarantee granted by the Republic of Italy and without any first-hand fund-raising (the "**Ordinary Account System**").

Under the Ordinary Account System, CDP sets out the terms and conditions applicable to each financing without specific restrictions, acting like any other financial intermediary aiming to achieve an appropriate return and financing on market terms.

In assuming credit commitments, CDP considers the credit standing of each potential borrower, its financial solidity, its business plan's economic and financial soundness, cash flow generation capacity, corporate structure and ability to provide adequate guarantees.

CDP offers a wide range of lending and guarantee products, ranging from plain-vanilla corporate loans to project finance transactions.

Taking into consideration the different targets, purposes and regulations of the relevant lending activities, CDP does not, in principle, commit to financing projects using funds falling under the Ordinary Account System as well as funds under Article 5, paragraph 7, letter (a) of Law Decree 269 at the same time.

### *B. Export credit and internationalisation (internazionalizzazione)*

As mentioned above, Article 8 of Law Decree 78 originally authorised the use of funding sources within the Separate Account System, including the use of postal savings, for operations aimed at supporting internationalisation and export credit, provided that the intervention by CDP is supported by guarantee or insurance policies issued by SACE. Article 8 has been implemented through a decree issued by the MEF on 22 January 2010.

Subsequently, Article 1, paragraph 44, of Law No. 147 of 27 December 2013 (the so-called "**Stability Law 2014**") established, through the amendment of Article 8 of Law Decree 78, that the intervention of CDP in internationalisation and export were not limited to transactions guaranteed or insured by SACE but, more generally, by another insurance institution whose obligations are guaranteed by a State.

Consequently, on 23 December 2014, the MEF issued a new decree in respect of the Stability Law 2014, published in the Official Gazette of the Republic of Italy No. 35 of 12 February 2015, implementing the amendments introduced by the Stability Law 2014, pursuant to which CDP is authorised to: (i) provide, at market conditions,

the banks with the necessary funding to grant loans in connection with transactions for the internationalisation of enterprises and exportation, provided that such transactions are insured or guaranteed by SACE or other export credit agencies, from national development banks or other financial institutions established pursuant to international agreements; and (ii) directly finance, at market conditions, transactions to support the internationalisation of enterprises and exportation, provided that such transactions are guaranteed or insured by any export credit agencies, national development banks or other financial institutions established pursuant to international agreements, in the case of financing transactions for amounts exceeding Euro 25 million. Such direct lending provides up to 50 per cent. of total funding in the event of co-financing or for a higher percentage should the particular temporal characteristics or dimensions of the financing not be compatible with the intervention of the banking system.

Subject to the above provisions, financial conditions applicable to financing described above are defined on a case by case basis in accordance with market conditions.

With Article 3 of Law Decree No. 3 of 24 January 2015 ("**Law Decree 3**"), as converted with amendments into Law No. 33 of 24 March 2015 ("**Law 33**"), Article 8 of Law Decree 78 has been further amended. The current Article 8 now sets forth that CDP may support export credit and internationalisation transactions also without the insurance or guarantee of SACE or any other export credit agencies, national development banks or other financial institutions established pursuant to international agreements.

On 29 September 2016, the shareholders' meeting of SACE approved the transfer of 76.005 per cent. of SIMEST's shares from CDP to SACE. This was an important step aimed at creating an integrated mechanism to support the growth and international competitiveness of the national production system. The integration of the two companies, which have already been working in close collaboration since the beginning of the year 2016, within the CDP Group combines the insurance-financial products, services and expertise of SACE and SIMEST with the overall product offering of the CDP Group. The objective is to offer Italian companies integrated support to meet all their requirements related to exports and internationalisation: from credit insurance to foreign investment protection, from financial guarantees for accessing bank credit to factoring services, from bonds to win competitive contracts to protection against construction risks, from equity investment to low-interest loans and export credit.

### *C. Financing in support of enterprises and other entities*

Pursuant to the recent legislation mentioned above, funds under Article 5, paragraph 7, letter (a) are also used by CDP in other supporting initiatives in favour of enterprises.

#### Transactions in favour of small and medium-sized enterprises

As mentioned above, pursuant to article 3, paragraph 4-*bis* of Law Decree No. 5 of 10 February 2009 ("**Law Decree 5**"), as integrated by the Budget Law 2010, among the transactions listed in the amendment to letter (a) of paragraph 7 of Article 5, CDP



may also carry out transactions in favour of small and medium-sized enterprises ("**SMEs**") for the purpose of supporting the economy.

Pursuant to such legislation and CDP's by-laws, transactions in favour of SMEs may be conducted through the banking system or through the subscription of participations in investment funds managed by asset management companies authorised to carry out collective portfolio management activities pursuant to Article 33 of Legislative Decree No. 58 of 24 February 1998, whose corporate purpose fulfils one or more of the institutional objectives of CDP.

In the context of transactions conducted through the banking system, CDP assumes the risk of insolvency of the banks through which the funding is granted to the SMEs. In 2009, an amount of up to Euro 8 billion (the "**Plafond PMI**") was allocated to finance the banking system for the granting of loans in favour of SMEs, for investments and the increase of working capital. In July 2012, CDP completed the distribution of the entire amount of Euro 8 billion.

In 2012, given SMEs' continuing difficulties to access loans, CDP deemed it necessary to strengthen its commitment to supporting the economy, by making available a further amount of up to Euro 10 billion (the "**New Plafond PMI**"), Euro 8 billion of which has the same purpose as the Plafond PMI (the "**New Plafond PMI – Investments**"), but, with respect to the first *plafond*, the exposure of CDP towards the banks is guaranteed by the granting of security. CDP has also allocated Euro 2 billion of the New Plafond PMI to contribute towards solving the issues concerning the delays in payment by the public administration (the "**New Plafond PMI - Claims vs. PA**"). Through the resources provided by CDP, the banking system will carry out transactions in favour of SMEs having one or more claims against the public administration, arising out of contracts for works, services and supplies that have been certified as liquid and enforceable.

In August 2014, in consideration of the Italian government's initiatives aimed at reducing stock of claims against the public administration (e.g. Law Decree No. 35 of 2013), CDP closed the operation of the New Plafond PMI - Claims vs. PA and allocated its resources to the tranche of the *Piattaforma Imprese* dedicated to SMEs (as further described below).

Pursuant to Article 2 of Law Decree No. 69 of 21 June 2013 ("**Law Decree 69**"), an amount of up to Euro 2.5 billion of funds under Article 5, paragraph 7, letter (a) may be used to provide funds to the financial system for granting loans in favour of SMEs, to be allocated to investments in new machinery, plants and equipment (the "**Capital Goods Funds**"). The Ministry of Economic Development will directly grant a subsidy to those SMEs that are granted such loans, in order to reduce borrowing costs. As in the New Plafond PMI, the exposure of CDP towards the banks is guaranteed by the granting of security. Considering the great success of the initiative, the budget law for 2015 (Law No. 190 of 23 December 2014) authorised CDP to double the resources of the Capital Goods Funds; consequently, in January 2015, CDP increased its resources to an amount of up to Euro 5 billion.

Article 8 of Law Decree 3, converted into law with amendments by Law 33, amended Law Decree 69 by providing, among other things, that government grants may be provided to SMEs that have obtained a loan under Law Decree 69 that need not

necessarily be drawn on the reserves of the Separate Account System of CDP. In order to implement this provision, on 17 March 2016, the Ministry of Economic Development, the ABI and CDP entered into a further addendum to the agreement dedicated to the Capital Goods Funds. With the introduction of this addendum, important process and product improvements have been made, in particular through the introduction of a special line of funding that banks and financial institutions can use when loans granted with CDP's funds are guaranteed by the guarantee fund for SMEs. Again with reference to the Capital Goods Funds, on 4 November 2016, CDP signed a loan agreement with the Council of Europe Development Bank (the "**CEB**") for an amount of Euro 150 million, in order to reduce the costs of CDP's funding. An additional loan agreement with the CEB, for an amount of Euro 290 million, was entered into on 18 April 2018.

The budget law for 2014 (Law No. 147 of 27 December 2013) extended the perimeters of operations for the purpose of supporting the economy, by amending Article 3, paragraph 4-*bis* of Law Decree 5, by introducing the possibility of providing funds, through banking intermediaries, for also granting loans to large enterprises.

Pursuant to such provisions and to CDP's by-laws, in January 2014, CDP launched several initiatives that, in continuity with the New Plafond PMI, have been the subject of a new agreement with the ABI in August 2014, dedicated to the *Piattaforma Imprese*.

Firstly, in order to broaden the base of the potential beneficiaries, CDP adopted - both for the New Plafond PMI and the *Piattaforma Imprese* - a new definition of SME (from the EU-wide definition to the EIB definition, i.e. enterprises with less than 250 employees, regardless of the economic data).

Furthermore, in consideration of the imminent completion of the distribution of the entire amount of Euro 8 billion of the New Plafond PMI - Investments (that occurred in April 2015) - CDP enclosed all products (activated in accordance with Article 3, paragraph 4-*bis* of Law Decree 5) dedicated to promoting access to credit for enterprises through the intermediation of the banking system in the *Piattaforma Imprese*. The *Piattaforma Imprese*, with an amount of up to Euro 5 billion, is composed of: (i) a fund, dedicated to the same purpose as the previous Plafond PMI, for an amount of Euro 2 billion (from the resources of the New Plafond PMI - Claims vs. PA); (ii) a new fund, dedicated to "mid-cap" enterprises (i.e. those with up to 3,000 employees), in an amount of Euro 2 billion for the granting of loans for investments and the increase of working capital; (iii) a new fund dedicated to SME networks, for an amount of up to Euro 500 million, aimed at supporting SMEs' consolidation and scale growth; and (iv) a new fund, originally dedicated only to post-financing of letters of credit, for an amount of up to Euro 500 million. With reference to the fund referenced under (iv) above, in February 2015 CDP extended its purpose to all types of export financing of Italian enterprises and increased its resources to an amount of up to Euro 1 billion in order to enhance the supply of CDP in support of export and internationalisation of the enterprises.

As in the New Plafond PMI, the exposure of CDP towards the banks in the *Piattaforma Imprese* is guaranteed by the granting of security. Furthermore, for the tranche dedicated to export, banks may constitute a pledge on Italian government bonds.

On the basis of levels of application of the *Piattaforma Imprese*, and in order to increase its potential and efficiency, the Board of Directors in March 2016 resolved to:

- (a) increase the maximum overall amount of the *Piattaforma Imprese* (bringing it to Euro 10 billion), through the increase of *Plafond PMI* (i.e. medium-long-term funding to the Italian banking system dedicated to the financing of investments and working capital to SMEs, i.e. enterprises with a workforce of up to 249 employees) and *Plafond MID* (i.e. medium/long-term funding to the Italian banking system dedicated to the financing of investments and working capital to so-called Mid Caps i.e. enterprises with a workforce of 250 to 3,000 employees); in particular, the amount of *Plafond PMI* has been increased to Euro 6 billion, of which approximately Euro 984 million results from the transfer to *Plafond PMI* of the remaining amount available under the funding provided by CDP for operations aimed at supporting internationalisation and export credit, and the amount of the *Plafond MID* has been increased to Euro 3.5 billion;
- (b) introduce in the *Plafond PMI* and the *Plafond MID* further maturity or longer duration (12 years) - beyond the maximum duration ordinarily offered (10 years) - providing, in order to encourage extending the duration of term loans, that the minimum duration of the loans in favour of enterprises by the banks with such funding is fixed at 10 years; and
- (c) redefine the scope of activity of the *Plafond Reti PMI* (now renamed *Plafond Reti e Filiere*), through the broadening of its capacity to finance; in particular, the financing of other forms of business combinations and also of companies such as Mid Caps.

Such amendments to *Piattaforma Imprese* were implemented through an addendum to the agreement between CDP and the ABI, signed on 17 May 2016. Moreover, in order to boost the use of the funds, the *Plafond Reti e Filiere* benefits from a specific line of funding made available by the EIB.

In addition, following the completion of the reform of Title V of the Banking Act, which has subjected non-bank financial intermediaries to a supervisory regime equivalent to that applicable to banks, CDP in May 2016 approved an amendment to its by-laws, to include these intermediaries in those qualified to participate in the programme dedicated to supporting the economy. When such reform is consolidated, CDP and the ABI will make the consequent changes to the existing agreements.

Also for the purpose of enhancing SMEs' access to bank lending, CDP on 25 May 2016, launched a specific Euro 1 billion purchase programme of asset-backed securities guaranteed by SME loans originated by Italian banks (the "**SME ABS**").

The initiative follows the provisions of the Stability Law 2014, which enabled the purchase of SME loan-backed securities – issued within the framework of the Italian Securitisation Law – by CDP.

In the field of securitisation, CDP has also joined the EIF-NPIs Securitisation Initiative (the "**ENSI Platform**"), an initiative set up in cooperation between the

European Investment Fund (the "EIF") and the main EU National Promotional Institutions, including CDP, with the aim of facilitating SMEs' access to bank lending through securitisation.

Within the ENSI Platform, CDP has thus far purchased mezzanine tranches of SME loan-backed securities for about Euro 250 million, in five different transactions, all covered by a first-demand guarantee issued by the EIF.

Since the end of 2017, outside the scope of the ENSI Platform, CDP has also purchased senior tranches of SME ABS for a total of Euro 440 million.

Along with that which is provided for by the *Plafond Casa* (as defined below) (in the purchase of Italian covered bonds and residential mortgage-backed securities), the originator of ABS is requested to commit itself – by means of a side letter – to disburse new SME loans for an amount at least equal to the securitisation tranches purchased by CDP.

#### Transactions for financial institutions' capital optimisation in favour of SMEs' access to bank lending

In the field of financial institutions' capital optimisation, in the second quarter of 2016, CDP started a cooperation with the EIF aimed at implementing an investment platform named "EFSI Thematic Investment Platform for Italian SMEs" (the "**EFSI Thematic Investment Platform**") for the provision of guarantees in favour of SMEs. The EFSI Thematic Investment Platform, approved within the the Investment Plan for Europe (the "**Juncker Plan**") framework on 23 September 2016, allows CDP to issue guarantees on 80 per cent. of newly originated bank loan/guarantee portfolios, up to Euro 3.1 billion, with a loss cap equal to 9 per cent. of the guaranteed amount. The EFSI Thematic Investment Platform was officially launched on 16 December 2016.

The guarantee will cover a portfolio of up to Euro 2.5 billion, with a loss cap set at Euro 225 million. The scheme features the activation of two forms of counter-guarantees in favour of CDP: 1) by the EIF, granted free of charge and backed by COSME funds, on 50 per cent. of CDP's exposure; and 2) by the MEF, granted upon consideration and backed by the monetary fund provided for by Article 1, paragraph 825 of the Stability Law 2016, on 30 per cent. of CDP's exposure.

The first transaction performed on the EFSI Thematic Investment Platform, which was initiated in June 2017, related to a new portfolio of SME guarantees originated by the Italian SME Guarantee Fund (established by Article 2, paragraph 100, letter (a) of Law No. 662 of 23 December 1996), that have been counter-guaranteed by CDP for up to Euro 3 billion, with the above-mentioned thresholds in terms of guarantee rate and loss cap.

A second transaction on the EFSI Thematic Investment Platform, whose structure is similar to the previous one, was executed on 29 March 2018 and contains the provision of 80 per cent. of counter-guarantees, with a 10 per cent. loss cap, in favour of the Italian SME Guarantee Fund to cover a Euro 200 million worth portfolio comprising new guarantees to SMEs of the creative and cultural sectors. The scheme features the activation by CDP of a counter-guarantee provided by the EIF, free of charge, backed by the "Creative Europe" Programme funds, on 70 per cent. of CDP's exposure.

In line with the provisions of the Stability Law 2016 that authorises CDP to execute “financial instruments” backed by ESI Funds (European Investment and Structural Funds) as per Regulation (UE, EURATOM) n. 966/2012 and Regulation (UE) n. 1303/2013, on 15 March 2018, CDP entered into a financing agreement with the Emilia-Romagna Region. Pursuant to this agreement, CDP has been assigned regional funds that will be employed to issue 80 per cent. counter-guarantees, with a 10 per cent. loss cap, on new SME guarantee portfolios originated by the mutual credit guarantee consortia Confidi (“**Confidi**”), up to approximately Euro 120 million. The aim of this initiative is to broaden Confidi’s capacity to issue new guarantees in order to enhance SMEs’ chances to obtain bank loans. The sums assigned by the Region will be used to cover 70 per cent. of CDP’s exposure.

A similar agreement, entered into on 9 June 2018 between CDP and the Italian Ministry of Agricultural, Food, Forestry and Tourism Policies, focuses on the Italian olive-growing and oil-making sector and features the provision of CDP guarantees (entirely backed by ministerial funds) on new debt transactions, for up to Euro 140 million, originated by banks and Confidi in favour of oil making associations. CDP guarantees are provided at a 70 per cent. rate with a loss cap of 10 per cent..

#### Transactions to support “alternative financing

In 2017, CDP entered into a partnership with ELITE S.p.A., a Platform launched by Borsa Italiana S.p.A. (*i.e.* the Italian stock exchange) together with the association of industrial enterprises Confindustria, the MEF and the Ministry of Economic Development, aimed at supporting growth and capital raising by Italian high potential enterprises. Within this collaboration, CDP: i) acquired a 15 per cent. minority stake in ELITE’s share capital; ii) participated in the structuring of the first “basket bond” which is a bond backed by a pool of “mini-bonds” specifically issued by ELITE companies. Through this bond-pooling deal, participating enterprises managed to reach sufficient critical mass to attract institutional investors, CDP and the EIB among others, raising Euro 122 million.

In order to increase access to lending by enterprises, CDP starting in 2016, has developed a business line consisting of direct lending to specialised financial institutions to enhance their capability to finance the real economy.

#### Other transactions in favour of enterprises and other entities under special law provisions

Funds under Article 5, paragraph 7, letter (a) are also used by CDP in other supporting initiatives in favour of enterprises and other entities established under special law provisions, such as the funds indicated below.

Pursuant to Article 1, paragraphs 354 to 361, of Law No. 311 of 30 December 2004 (the budget law for 2005) which reformed certain public incentives in order to (i) transform such incentives from the Italian State’s sunk contribution to subsidised loans granted by CDP (in some cases in addition to a sunk contribution granted directly by the Italian State), and (ii) to involve the banking system in the evaluations relating to the granting of public incentives, providing for its direct participation in the related risks through the necessary complementary granting of medium-long-term loans under market conditions - a revolving reserve fund (*Fondo rotativo per il sostegno alle imprese e gli investimenti in ricerca*) (the “**Revolving Fund for**

**Enterprises**") was implemented, within the Separate Account System, for the granting of fixed rate subsidised loans with CDP funding (the "**Subsidised Loans**").

The Revolving Fund for Enterprises initial resources have been established by law for an amount equal to Euro 6,000 million and such funds are distributed among various incentive programme by CIPE (the Inter-Ministerial Committee for Economic Programming) that also determines, *inter alia*, the general criteria for the issuance of Subsidised Loans and the minimum interest rate applicable to the beneficiaries of the Subsidised Loans. The minimum annual interest rate applicable to the beneficiaries of the Subsidised Loans currently provided for is 0.50 per cent., with their maximum duration being 15 years.

The interest rate payable on amounts disbursed by CDP as Subsidised Loans is determined by virtue of a MEF decree as interest due to CDP. The difference between the rate thus established and the Subsidised Loans interest rate due by the relevant beneficiary is charged to the Italian State, together with an overall amount equal to 0.40 per cent. of the amount granted annually as Subsidised Loans by way of reimbursement of the expenses incurred by CDP in managing the fund.

As to the involvement of the banking system in the granting of public incentives, the above-mentioned reform provides that having access to a medium-long-term loan granted under market conditions by a banking institution (the "**Lender**") is an eligibility requirement to obtain CDP Subsidised Loans. The evaluation of the duration, amount and conditions (including the security package, if necessary) of the bank loan and the CDP Subsidised Loan are entrusted to the Lender, which is therefore responsible for the evaluation of the creditworthiness of the beneficiary, provided that the bank loan and the Subsidised Loan shall be guaranteed by the same security package, if any.

The obligation of reimbursing the Subsidised Loan and related interests may be assisted, as a final and residual resource, by a guarantee granted by the Italian State, provided for by decree of the MEF and issued in accordance with the criteria, conditions and patterns established in the decree.

Currently the highest quota (above 50 per cent.) of the Revolving Fund for Enterprises' resources is allocated to the research and pre-competitive development sectors. Pursuant to Article 30 of Law Decree No. 83 of 22 June 2012 ("**Law Decree 83**"), as converted into law, the competent public authorities carried out a survey of the unused resources of the Revolving Fund for Enterprises, 70 per cent. of which shall be set aside for the purposes of a fund constituted by the Ministry of Economic Development (the "**Fund for Sustainable Growth**").

On 17 March 2016, the Ministry of Economic Development, the ABI and CDP entered into a framework agreement setting out, *inter alia*, procedures for the granting of facilitated loans further to the implementation of measures of the Fund for Sustainable Growth that has access to the resources of the Revolving Fund for Enterprises.

On 28 July 2016, CDP, ABI and the Ministry of Economic Development signed two addenda to the aforementioned framework agreement, for the activation of two initiatives in the context of the Fund for Sustainable Growth ("**Agenda Digitale Italiana**" and "**Industria Sostenibile**"), for an amount of up to Euro 450 million. By

decree of the Ministry of Economic Development dated 18 October 2017, an additional Euro 350 million of resources of the Revolving Fund for Enterprises was allocated to the activation of the two initiatives.

On 28 July 2017, the Ministry of Economic Development, the ABI and CDP entered into a framework agreement setting out, *inter alia*, procedures for the granting of facilitated loans to support a specific measure of the Revolving Fund for Enterprises, for an amount of up to Euro 200 million, promoting the creation and growth of companies for the pursuit of purposes of social utility.

On 19 October 2017, the Ministry of Agricultural, Food, Forestry and Tourism Policies and CDP signed a framework agreement defining, *inter alia*, procedures for the granting of facilitated loans for an amount of up to Euro 200 million from the Revolving Fund for Enterprises, intended to favour the integration of the supply chain of the agricultural and agri-food system and the strengthening of the agri-food districts.

Furthermore, Law Decree No. 39 of 28 April 2009 as converted with modifications into law ("**Law Decree 39**") introduced some urgent provisions in favour of the population of the Region of Abruzzo which was affected by earthquakes in April 2009. Pursuant to Article 3, paragraph 3 of Law Decree 39, funds under Article 5, paragraph 7, letter (a) may be used, in an amount of up to Euro 2 billion, for the granting of funds to banks which operate in the areas affected by the earthquakes in order for them to grant subsidised loans to the people residing in such affected areas for the reconstruction or repair of properties classifiable as principal home which have been destroyed or declared inhabitable, or for the purchase of new properties also to be used as principal homes in substitution of those destroyed by the earthquakes. The reimbursement of the loans by the final beneficiaries to the banks will be guaranteed by the Republic of Italy pursuant to terms and modalities to be established by decree of the MEF. Pursuant to Article 3, paragraph 3-*bis* of Law Decree 39, introduced by Article 4, paragraph 8-*bis* of Law Decree No. 133 of 2014, converted into Law No. 164 of 2014, the reimbursement of the loans by the banks to CDP is guaranteed by the Republic of Italy pursuant to the terms and practicalities established by decree of the MEF. In particular, the decree established that this public guarantee is on first demand, irrevocable and unconditional. In December 2012, CDP completed the distribution of the entire amount of Euro 2 billion.

In order to remedy the damage caused by the earthquake of May 2012 which affected some of the northern regions of Italy, the Italian government adopted two provisions in favour of the population of the regions of Emilia-Romagna, Lombardy and Veneto, allowing for the creation of two additional CDP funds in the aggregate amount of Euro 12 billion. The first one (the "**Plafond Moratoria Sisma 2012**", equal to Euro 6 billion), introduced by Article 11 of Law Decree No. 174 of 10 October 2012, as converted into law, and Article 1 of Law Decree No. 194 of 16 November 2012, as integrated by Article 1, paragraphs 365-373, of Law No. 228 of 24 December 2012 and Article 6 of Law Decree No. 43 of 26 April 2013, as converted into law, is dedicated to the granting of funds to banks which operate in the areas affected by the earthquakes in order for them to grant subsidised loans (with a maximum duration of two years, later extended to eight years by several regulatory provisions) to the enterprises and workers operating in such affected areas for the deferment of payment of taxes. The second one (the "**Plafond Ricostruzione**

**Sisma 2012**", for an additional amount of Euro 6 billion), introduced by Article 3-*bis* of Law Decree No. 95 of 6 July 2012, may be used for the granting of funds to banks which operate in the areas affected by the earthquakes in order for them to grant subsidised loans (with a maximum duration of 25 years) to the people residing and the enterprises operating in such affected areas for the reconstruction or repair of properties for residential and productive use, including plants and equipment. In both cases, the reimbursement of the loans by the banks to CDP is guaranteed by the Republic of Italy pursuant to the terms and practicalities established by decrees of the MEF. In particular, the decrees established that these public guarantees are on first demand, irrevocable and unconditional.

Moreover, in order to remedy the damage caused by the flooding in the region of Sardinia in November 2013, the Italian government adopted provisions in favour of the population of the region of Sardinia. Pursuant to Article 7 of Law Decree No. 151 of 30 December 2013, CDP made available a maximum amount of Euro 90 million, analogous to the Plafond Moratoria Sisma 2012. The reimbursement of the loans by the banks to CDP is guaranteed by the Republic of Italy in accordance with the terms and practicalities established by a decree of the MEF. In particular, the decree established that this public guarantee is also on first demand, irrevocable and unconditional.

In addition, to implement the provisions of Article 1, paragraphs 422 to 428 of the Stability Law 2016, CDP approved, on 25 May 2016, the establishment of a new plafond of up to Euro 1.5 billion (the "**Plafond Eventi Calamitosi**"), dedicated to the financing of interventions of private and productive reconstruction after natural disasters that occurred throughout Italy from 2013. The guidelines and application rules of the Plafond Eventi Calamitosi were defined through an agreement with ABI, signed on 17 November 2016.

Moreover, in order to remedy the damage caused by several earthquakes that struck the territories of Central Italy from 24 August 2016, Article 5 of Law Decree No. 189 of 17 October 2016 introduced a new instrument (the "**Plafond Sisma Centro Italia**"), that replicates the mechanisms of the Plafond Ricostruzione Sisma 2012. In particular, it may be used for the granting of funds to banks which operate in the areas affected by the earthquakes in order for them to grant subsidised loans (with a maximum duration of 25 years) to the people residing and the enterprises operating in such affected areas for the reconstruction or repair of properties for residential and productive purposes, including plants and equipment. The reimbursement of the loans by the banks to CDP is guaranteed by the Republic of Italy pursuant to the terms and practicalities established by a decree of the MEF. In particular, the decree established that these public guarantees are on first demand, irrevocable and unconditional. The maximum amount of the Plafond Sisma Centro Italia falls within the annual limit set by the budget law for 2017 (currently estimated at about Euro 4 billion). The guidelines and application rules of the Plafond Sisma Centro Italia were defined in an agreement with ABI, signed on 18 November 2016.

As part of the initiatives in favour of the territories of Central Italy affected by the earthquakes from 24 August 2016, the CDP Board of Directors on 27 February 2017 approved the establishment of a plafond of an amount of up to Euro 560 million (the "**Plafond Moratoria Sisma Centro Italia**"), dedicated to the granting of funds to banks in order for them to grant subsidised loans (with a maximum duration of eight



years) to the enterprises and workers operating in such affected areas for the deferment of payment of taxes in accordance with Article 11 of Law Decree No. 8 of 9 February 2017 ("**Law Decree 8**"). The reimbursement of the loans by the banks to CDP is guaranteed by the Republic of Italy pursuant to the terms and practicalities that will be established by a decree of the MEF. The guidelines of the instrument will be defined through a special agreement with ABI, when Law Decree 8 will be converted into law.

Article 2, paragraph 1, letters (a) and (b) of Law Decree No. 102 of 31 August 2013, introduced the possibility for CDP to use funds under Article 5, paragraph 7, letter (a) for the residential sector. In particular, the provisions allowed CDP to (a) provide funds to the banking system for the granting of mortgages in favour of individuals, dedicated to the purchase of residential property, with priority given to principal houses, and to restructuring costs intended to improve energy efficiency; and (b) to purchase cover bonds and asset-backed securities, with underlying residential mortgages. Such legislation allowed CDP to launch, respectively, two initiatives, for a total amount of Euro 5 billion, allocated as follows: (i) Euro 2 billion dedicated to the *Plafond Casa*, and (ii) Euro 3 billion to the purchase of securities.

On the basis of levels of application of the resources of the *Plafond Casa*, in March 2016 the Board of Directors resolved to increase the maximum amount of (i) *Plafond Casa* to Euro 3 billion, implemented by an addendum to the agreement between CDP and ABI, executed on 7 April 2016; and (ii) the programme of purchase of securities, from Euro 3 billion to Euro 5 billion.

Finally, the Kyoto Fund, established by Article 1, paragraphs 1110 to 1115 of Law No. 296 of 27 December 2006, is a fund consisting of an amount of up to Euro 600 million of public resources, for the granting of subsidised loans in order to reduce emissions responsible for the greenhouse effect and energy efficiency. The aforementioned legislation confers the management of the fund to CDP.

Through the Kyoto Fund, subsidised loans may be granted, at a rate of 0.50 per cent. per annum, with maturities ranging from three to six years (15 years for the public sector). The other beneficiaries can be enterprises, individuals, condominiums and private legal entities.

The first window **of** the Kyoto Fund has been active since March 2012.

The purposes of the Kyoto Fund have been redefined by Article 57 of Law Decree 83. In particular, funds reserved for enterprises (ESCos included) shall be used for granting subsidised **loans** for projects in green economy sectors and connected to the safety of the territory from hydrogeological and seismic risks. The second window of the Kyoto Fund was fully implemented in the first half of 2013.

More recently, pursuant to Article 9 of Law Decree No. 91 of 2014 ("Law Decree 91"), converted into Law No. 116 of 2014, the Kyoto Fund has been subject to further reform: the remaining resources of the Kyoto Fund, for an amount of up to Euro 350 million, may be used for the granting of subsidised loans to Public Entities in order to implement measures to increase the energy efficiency of school buildings, including kindergartens and university end-use efficiency, with CDP being confirmed as manager of the fund. The effective implementation of this provision has been defined by a decree of the Minister of the Environment and the MEF, in consultation with the

Minister of Economic Development and the Minister of Education, University and Research. This window lasted until 31 December 2018.

### Enterprises ("*Imprese*")

The Enterprises ("*Imprese*") Department, is in charge of the financing of initiatives promoted by counterparties in any sectors (e.g. industrial, agri-food, automotive, chemical and pharmaceutical, bio-chemical, publishing, manufacturing, mechanical, instrumental, IT, electronics, commercial, mass distribution, logistics, aerospace and defence, construction, real estate, media, shipping, iron, steel, metal, cement, paper, glass, wood, plastics, materials, culture, tourism, fashion, luxury and services, excluding sectors reserved to other departments, through loan products of any kind, under the Ordinary Account System or the Separate Account System in accordance with regulations and CDP By-laws.

New loan agreements, guarantees and corporate bonds subscribed over the year totalled Euro 0.8 billion, showing a slight decline compared to 2017. Loan agreements showed a reduction in average volumes per transaction, also due to increased support to the mid-corporate segment, characterised by smaller dimensions. The new deals are characterised by a relevant diversification in terms of sectors and are mostly directed to enterprises operating in the manufacturing, mechanical, agri-food, automotive, defence, healthcare and shipbuilding industries.

During 2018, the first three transactions of the EFSI Thematic Investment Platform concerning Corporate Projects were subscribed for a total amount of Euro 0.1 billion. The initiative, developed within the the Juncker Plan, supports the investment plans of the Italian enterprises (mainly national "mid-caps"), together with the EIB.

Disbursements in 2018 amounted to Euro 0.4 billion, showing a decrease of 56 per cent. compared to 2017, due to lower transaction volumes on the capital markets, which generally involve an immediate disbursement.

As at 31 December 2018, the stock of loans totalled Euro 2 billion, including IFRS adjustments, recording an increase of 18 per cent. over the stock at the end of 2017 (equal to Euro 1.7 billion). Growth in the stock of loans was mainly driven by the subscription of new securities and disbursements throughout the year.

## **CDP ACTIVITIES**

### **A. The Account Systems**

#### *A.1 The Separate Account System*

Pursuant to paragraph 8 of Article 5 of Law Decree 269 and to article 6 of CDP's by-laws, CDP has established a Separate Account System in which the activities under letters (A1), (A2), (C), (D) where applicable, (E) where applicable, (F), (G) and (H) of article 3 of CDP's by-laws where applicable, as well as any other instrumental, connected or ancillary activity carried out using funds pursuant to Article 5, paragraph 7, letter (a), are to be registered and managed. The Separate Account System is established for accounting and organisational purposes only, so that from a legal point of view, CDP remains a single legal entity and any creditors of CDP

may recover their claims by attaching them to all of CDP's assets (except for those segregated in favour of certain creditors only pursuant to Article 5, paragraph 18).

The Separate Account System is managed in line with applicable transparency and economic safeguard criteria. Article 6 of CDP's by-laws has been amended in order to specify that, for the transactions referred to in letter (A2) of paragraph 1 of article 3 of CDP's by-laws, the economic and financial sustainability of each project shall be assessed.

Such organisational and accounting separation aims at highlighting the economic balance of the Separate Account System and at enabling the MEF to exercise its powers to issue guidelines thereon and to ensure compliance with EU legislation on State Aid, competition and transparency.

Pursuant to paragraphs 9 and 11 of Article 5 of Law Decree 269, the MEF has the power to determine the general policies of the Separate Account System and to issue decrees on, *inter alia*, the determination of the criteria for the definition of general economic terms of the demand of passbook savings accounts, postal savings bonds, other securities and other financial transactions guaranteed by the Republic of Italy, as well as those for the granting of loans by means of funds pursuant to Article 5, paragraph 7, letter (a) of Law Decree 269 and for the management of the shareholdings and participations held by CDP.

The implementation by CDP of the decrees or guidelines issued by the MEF in connection with the Separate Account System is ensured by the attendance of Additional Directors (as defined below) at the meetings of the board of directors of CDP (the "**Board of Directors**") convened to resolve on matters relating to the Separate Account System (for details on the Additional Directors see paragraph "*Board of Directors, Managing Director and General Manager*" below). To pass a valid resolution involving the management of the Separate Account System, at least two Additional Directors are required to be present at the board meeting and to vote for its adoption.

In addition, the Supervisory Board (as defined below) is composed of four members of the Italian Senate (*Senato della Repubblica*), four members of the Italian Chamber of Deputies (*Camera dei Deputati*), three judges of the Council of State (*Consiglio di Stato*), and one judge of the Court of Accounts (*Corte dei Conti*), and supervises the Separate Account System of CDP pursuant to paragraph 9 of Article 5 and Royal Decree No. 453 of 2 January 1913 ("**Royal Decree 453**").

CDP and Poste entered into a new agreement (the "**Poste Italiane Distribution Agreement**") for the distribution of postal savings instruments, on 14 December 2017, for a three-year term ending on 31 December 2020. The Poste Italiane Distribution Agreement consolidates the relationship between CDP and Poste, strengthening their partnership to serve Italian investors and supporting Italy's economic growth.

Pursuant to the Poste Italiane Distribution Agreement, the remuneration of Poste, which is the only distributor of postal savings instruments issued by CDP, is proportionate to the stock of postal savings products (passbook savings accounts and postal savings bonds) and the annual flows of bond subscriptions.

Safeguard mechanisms and reductions in remuneration due to Poste are also foreseen in case the net funding deviates from the objectives set for each year.

Postal savings, which allow CDP to pursue its institutional mission, constitute the main source of funding in the Separate Account System for CDP. As at 31 December 2018, postal savings represented 77 per cent. of CDP's total funding in the Separate Account System (equal to Euro 258 billion out of a total of Euro 335 billion).

Any and all transactions and business activities entered into by CDP in connection with funding and lending under the Separate Account System are exempt from registration tax, stamp duty, mortgage tax and other indirect taxes.

### *A.2 The Ordinary Account System*

All of CDP's other business activities that are not specifically attributed to the Separate Account are carried out by the Ordinary Account organisational unit. While not specifically cited in article 5 of decree law 269, the Ordinary Account encompasses the other activities of CDP, namely, those that are not assigned by law to the Separate Account.

In particular, pursuant to article 5, paragraph 7, letter b), of decree law 269, CDP's Articles of Association include among the activities designed to achieve its mission that are not assigned to the Separate Account:

- the granting of loans, preferably under joint financing arrangements with credit institutions, for: (i) works, systems, networks and equipment designed for initiatives of public utility; and (ii) investments in the research, development, innovation, protection and enhancement of cultural heritage, the promotion of tourism, the environment and energy efficiency sustainable development, the green economy and initiatives for company growth, including through business mergers and/or acquisitions, in Italy and abroad;
- acquiring, including indirectly, equity investments in companies of major national interest with a stable financial position, stable financial performance and adequate profit-generating prospects which satisfy the requirements set out in the decree of the Minister of the Economy and Finance pursuant to article 5, paragraph 8-bis, of the abovementioned decree law;
- acquiring: (i) covered bank bonds backed by mortgages on residential real estate and/or securities issued under law 130 of 30 April 1999, as part of securitisation transactions involving receivables deriving from mortgages on residential real estate; and (ii) securities issued under law 130 of 30 April 1999, as part of securitisation transactions involving receivables from SMEs; and
- providing consultancy services and conducting studies, research and analysis of economic and financial matters.

## **FUNDING AND EQUITY**

### **A. Funding of the Separate Account System and Ordinary Account System**

### *A.1 Bilateral financing contracts with European Financial Institutions*

In addition to the postal savings instruments and the issue of Notes under the Programme, the funding required by CDP for carrying out the activities falling under the Separate Account System is raised by CDP by entering into loans with European financial institutions, such as the EIB and the CEB. This source of funding is also used by CDP to finance the activities falling under the Ordinary Account System, depending on the projects to be financed.

With regard to the credit facilities granted by the EIB, during 2018 CDP entered into new loan agreements for a total amount of Euro 680 million (Euro 650 million for the financing of Ferrovienord S.p.A. under the Ordinary Account System and Euro 30 million for the financing of Gaia S.p.A. under the Separate Account System). As regards the credit facilities granted by the CEB, during 2018 CDP signed new loan agreements for Euro 350 million to finance the Central Italy Earthquake Fund and for Euro 290 million to finance the Italian SMEs (both under the Separate Account System).

During 2018, CDP requested and obtained (i) new disbursements on credit facilities from the EIB for an aggregate amount of Euro 173 million mainly for the financing of school buildings and (ii) new disbursement on credit facilities from the CEB for an aggregate amount of Euro 130 million for the financing of the liquidity platform for granting loans in favour of SMEs, to be allocated to investments in new machinery, plants and equipment (the "**Capital Goods Funds**").

During first quarter of 2019, CDP also obtained new disbursements for an aggregate amount of Euro 129 million, including 53 million from the EIB for the financing of school buildings and Euro 76 million from the CEB for the financing of the Italian SMEs.

### *A.2 Multi-Currency Commercial Paper Programme (Programma di Cambiali Finanziarie)*

In 2014, CDP launched a new Euro 3 billion multi-currency Commercial Paper Programme (*Programma di Cambiali Finanziarie*) governed by Italian Law pursuant to Law No. 43 of 13 January 1994, as amended by Law No. 134 of 7 August 2012 (the "**EC Programme**"). At the beginning of 2018, the size of the EC Programme was increased to Euro 6 billion. The commercial papers issued by CDP may be listed on ExtraMOT PRO, a non-regulated market organised and managed by Borsa Italiana S.p.A. The EC Programme has obtained the STEP label from the STEP Secretariat. The proceeds may be used to finance both the Separate Account System and the Ordinary Account System. As of 31 December 2018, the nominal amount of outstanding issues under the Separate Account System was equal to Euro 1,225 million and equal to Euro 565 million under the Ordinary Account System.

### *A.3 Debt Issuance Programme*

With reference to medium-long term funding under the Programme, during 2018 CDP issued Notes for a nominal amount of Euro 1,627 million, of which: i) Euro 140 million was issued to support the Ordinary Account; and ii) Euro 1,487 million equivalent was issued to support the Separate Account, including a Euro 500 million

inaugural CDP Sustainability Bond. In the first quarter of 2019, CDP issued a new Social Bond for a nominal amount of Euro 750 million under the Separate Account System and Euro 200 million under the Ordinary Account System.

#### A.4 Domestic Programme

In 2015, CDP launched a domestic bond-issuance programme (the “Domestic Programme”) approved by CONSOB and reserved for retail investors (individuals residing in Italy). The purpose of the Domestic Programme is to expand the funding sources dedicated to the financing of projects of public interest, which were previously funded by postal savings products.

The first bond issued under the Domestic Programme was launched in March 2015. This bond – issued with a notional amount of Euro 1.5 billion – will expire on 20 March 2022 and bears a fixed-to-floating interest rate. Interest will be paid interest at a fixed rate for the first two years and at a floating rate for the subsequent five years.

### B. Equity Investments and Investment Funds

The following tables set out the equity investments and the investment funds under the Separate Account System and the Ordinary Account System of CDP as at 31 December 2018 and the carrying amount reported in the audited non-consolidated annual financial statements as at the same date:

#### B.1 Equity investments

| (thousands of euro)   | Main activity                           | As at 31/12/2018 |           |                   |
|---|---|------------------|-----------|-------------------|
|   |   | Account system   | % holding | Carrying amount   |
| <b>A. Listed companies</b>  |   |                  |           |                   |
| <b>Equity investments in companies subject to significant influence</b> |   |                  |           | <b>18,211,890</b> |
| 1. Eni S.p.A.   | Energy                                  | Separate         | 25.76%    | 15,281,632        |
| 2. Poste Italiane S.p.A.  | Financial services                      | Separate         | 35.00%    | 2,930,258         |
| <b>B. Unlisted companies</b>  |   |                  |           |                   |
| <b>Equity investments in subsidiaries</b>                               |   |                  |           | <b>12,089,283</b> |
| 3. SACE S.p.A.  | Finance/Export Credit                   | Separate         | 100.00%   | 4,251,174         |
| 4. CDP Reti S.p.A.  | Energy/Infrastructure                   | Separate         | 59.10%    | 2,017,339         |
| 5. CDP Equity S.p.A.  | Industrial                              | Separate         | 97.13%    | 3,419,512         |
| 6. Fintecna S.p.A.  | Industrial, Litigation & Restructurings | Separate         | 100.00%   | 2,025,836         |
| 7. CDP Immobiliare S.r.l.   | Real Estate                             | Separate         | 100.00%   | 374,021           |
| 8. CDP Investimenti SGR S.p.A.  | Management Company                      | Ordinary         | 70.00%    | 1,400             |
| <b>Equity investments in</b>  |   |                  |           | <b>15,110</b>     |

**companies subject to significant influence**

|   |                    |          |        |                   |
|---|--------------------|----------|--------|-------------------|
| 9. QuattroR SGR S.p.A.                            | Management Company | Separate | 40.00% | 800               |
| 10. Fondo Italiano d'Investimento S.p.A.          | Management Company | Separate | 43.00% | 5,848             |
| 11. Galaxy S.à r.l. SICAR                         | Infrastructure     | Ordinary | 0.00%  | -                 |
| 12. Europrogetti & Finanza S.r.l. in liquidazione | Bank/Finance       | Separate | 31.80% | -                 |
| 13. FSI SGR S.p.A.                                | Management Company | Separate | 39.00% | 1,170             |
| 14. Elite S.p.A.                                  | Financial services | Separate | 15.00% | 6,924             |
| 15. Risparmio Holding S.p.A.                      | Financial          | Separate | 20.00% | 368               |
| <b>Total</b>                                      |                    |          |        | <b>30,316,282</b> |

Amongst the main transactions carried out in 2018 that had an impact on the portfolio's carrying amount were the following:

- i. the conversion of the equity instruments of QuattroR SGR into shares carried out on 26 March 2018;
- ii. the completion of the liquidation of Galaxy S.à r.l. SICAR (placed in liquidation on 26 February 2018), approved by the Shareholders' Meeting on 25 June 2018, with distribution of approximately Euro 4 million;
- iii. CDP's injection of Euro 80.4 million of new capital in CDP Immobiliare, to cover the financial needs of the company and its investees; and
- iv. the impairment reversal on the equity investment in Fintecna for approximately Euro 162 million, and the value adjustment on SACE for approximately Euro 333 million.

Dividends received for 2018, including income from investment funds, totalled Euro 1,362 million and were mainly connected with the equity investments in ENI (Euro 768 million), CDP RETI (Euro 234 million), Poste Italiane (Euro 192 million), SACE (Euro 150 million) and Fintecna (Euro 11 million).

*B.2 Other investments: investment funds and investment vehicles*

CDP is a subscriber to investment funds and investment vehicles with the aim of facilitating:

- i. the development, international expansion and growth in size of Italian SMEs and start-ups;
- ii. investments in the sustainable living sector, in the development of public real estate assets, in tourism-hospitality real estate, in the residential rental sector

with next generation services, in supporting innovation and training and in property rental to the Public Administration; and

iii. investments in physical and social infrastructures:

- at the local level, in partnership with local authorities and with shareholder foundations. In this context, CDP also promotes public-private partnership (PPP) projects;
- at the national level, focusing on major works in partnership with Italian and foreign institutional investors; and
- at the international level, in support of infrastructure and network projects involving several countries, not only within the European Union, in cooperation with European institutions and foreign counterpart organisations (such as CDC, KfW and the EIB).

As at 31 December 2018, the investment portfolio in investment funds and investment vehicles totalled approximately Euro 2,384 million.

| <b>As at 31/12/2018</b>   |                            |                |           |                  |                     |
|---|----------------------------|----------------|-----------|------------------|---------------------|
| (thousands of euro)   | Investment sector          | Account system | % holding | Carrying amount  | Residual commitment |
| <b>A. Investment vehicles</b>   |                            |                |           | <b>225,330</b>   | <b>197,812</b>      |
| 1. Inframed Infrastructure società par azioni semplificata a capital variable (Fondo Inframed)      | Infrastructure             |                |           |                  |                     |
| - A units   |                            | Separate       | 38.92%    | 126,285          | 26,611              |
| - B units   |                            | Separate       | 0.0012%   | 4                | 1                   |
| 2. 2020 European Fund for Energy, Climate Change and Infrastructure SICAV-FIS Sa (Fondo Marguerite) | Infrastructure             | Separate       | 14.08%    | 53,145           | 5,587               |
| 3. European Energy Efficiency Fund SA, SICAV-SIF (Fondo EEEF)                                       | Energy                     |                |           |                  |                     |
| - A units   |                            | Separate       | 10.38%    | 14,602           | 37,312              |
| - B units   |                            | Separate       | 1.63%     | 2,294            | 5,693               |
| 4. Marguerite II SCSp (Fondo Marguerite II)   | Infrastructure             | Separate       | 13.42%    | 28,710           | 73,069              |
| 5. Connecting Europe Broadband Fund, SICAV-FIAR   | Broadband Infrastructures  | Separate       | 11.90%    | 290              | 49,539              |
| <b>B. Investment funds</b>  |                            |                |           | <b>2,159,119</b> | <b>2,603,681</b>    |
| 1. FIV Extra  | Public sector construction | Separate       | 100.00%   | 551,104          | 331,100             |
| 2. F2i – Terzo Fondo per le Infrastrutture  | Infrastructure             |                |           |                  |                     |



|   |                                |          |         |         |         |
|---|--------------------------------|----------|---------|---------|---------|
| - A units   |                                | Ordinary | 4.17%   | 107,650 | 41,665  |
| - C units   |                                | Ordinary | 0.0039% | 101     | 39      |
| 3. Fondo Investimenti per l'Abitare   | Social housing                 | Separate | 49.31%  | 438,928 | 456,198 |
| 4. Fondo Italiano d'Investimento - Fondo di Fondi                             | SMEs and export finance        | Separate | 20.83%  | 25,919  | 17,168  |
| 5. Fondo Italiano d'Investimento - FII Venture                                | Venture Capital                | Separate | 20.83%  | 8,413   | 6,178   |
| 6. F2i - Secondo Fondo Italiano per le Infrastrutture                         | Infrastructure                 |          |         |         |         |
| - A units   |                                | Ordinary | 8.05%   | 85,950  | 30,858  |
| - C units   |                                | Ordinary | 0.02%   | 228     | 82      |
| 7. FIV Plus   | Public sector construction     | Separate | 100.00% | 76,972  | 161,400 |
| 8. Fondo PPP Italia   | Infrastructure and PPP project | Ordinary | 14.58%  | 10,269  | 2,054   |
| 9. Fondo Immobiliare di Lombardia - Comparto Uno (formerly Abitare Sociale 1) | Social housing                 | Ordinary | 3.57%   | 12,867  | 7,000   |
| 10. FoF Private Debt  | SMEs and export finance        | Separate | 62.50%  | 88,780  | 135,747 |
| 11. FoF Venture Capital   | Venture Capital                | Separate | 76.69%  | 22,618  | 91,754  |
| 12. Fondo Atlante   | Banks and NPLs                 | Separate | 11.77%  | 103,552 | 905     |
| 13. Italian Recovery Fund   | Banks and NPLs                 | Separate | 12.90%  | 308,937 | 16,384  |
| 14. Fondo Investimenti per il Turismo (FIT)                                   | Tourism sector construction    | Separate | 100.00% | 93,800  | 157,415 |
| 15. Fondo QuattroR  | Enterprises                    |          |         |         |         |
| - A units   |                                | Separate | 41.96%  | 30,879  | 259,789 |
| - B units   |                                | Separate | 0.21%   | 156     | 1,352   |
| 16. Fondo FIA 2   | Smart Housing, smart working   | Separate | 100.00% | 10,442  | 88,350  |
| 17. FSI I (formerly FSI Mid Market Growth Equity Fund)                        | Enterprises                    |          |         |         |         |
| - A units   |                                | Separate | 38.39%  | 120,108 | 370,812 |
| - B units   |                                | Separate | 0.27%   | 766     | 2,605   |
| 18. Fondo Innovazione e Sviluppo  | Enterprises                    | Separate | 72.73%  | 26,020  | 170,000 |
| 19. Fondo FII Tech Growth   | Enterprises                    | Separate | 100.00% | 21,288  | 27,375  |
| 20. Vertis Venture 3  | Enterprises                    | Separate | 49.50%  | 937     | 18,459  |

|  |               |          |         |                  |                  |  |
|--|---------------|----------|---------|------------------|------------------|--|
| Technology Transfer                                  |               |          |         |                  |                  |  |
| 21. HI Crescltalia PMI                               | Enterprises   | Separate | 21.87%  | 5,451            | 14,383           |  |
| 22. Oltre Il SICAF<br>EuVECA S.p.A.                  | Social        | Separate | 21.02%  | 3,246            | 3,774            |  |
| 23. Fondo Federal<br>District                        | Public sector | Separate | 100.00% | -                | 70,000           |  |
|  | construction  |          |         |                  |                  |  |
| 24. Fondo Sofinnova<br>Telethon                      | Enterprises   | Separate | 24.69%  | 622              | 19,000           |  |
| 25. Fondo Credito<br>diversificato per le<br>imprese | Enterprises   | Separate | 23.84%  | 2,117            | 47,835           |  |
| 26. Fondo 360 POLIMI                                 | Enterprises   | Separate | 45.79%  | 1,000            | 19,000           |  |
| 27. Fondo Progress<br>Tech Transfer                  | Enterprises   | Separate | 49.49%  | -                | 20,000           |  |
| 28. Fondo Caravella                                  | Enterprises   | Separate | 50.00%  | -                | 15,000           |  |
| <b>Total</b>   |               |          |         | <b>2,384,449</b> | <b>2,801,492</b> |  |

The increase in the carrying amount of the portfolio, totalling approximately Euro 531 million, is essentially due to the movements in draw-downs and distributions to CDP (roughly Euro 560 million) net of the negative balance deriving from the valuation adjustments (approximately Euro 29 million).

The main changes included the draw-downs of Fondo Investimenti per l'Abitare, for approximately Euro 114 million, the Italian Recovery Fund for approximately Euro 134 million and FSI I, for approximately Euro 122 million.

With reference to commitments, as at 31 December 2018 there were residual commitments to investment funds and investment vehicles, amounting to around Euro 2,801 million. Amongst the main subscriptions during the course of the year, were those relating to:

- Fondo Investimenti per il Turismo, for a further Euro 150 million;
- Fondo Federal District, for Euro 70 million;
- Sofinnova Telethon, 360 POLIMI and Progress Tech Transfer Funds, through the ITAtech Platform, for a total of Euro 60 million;
- Fondo Innovazione e Sviluppo, for a further Euro 50 million;
- Connecting Europe Broadband Fund SICAV-FIAR, for Euro 50 million;
- Fondo Credito diversificato per le imprese, for Euro 50 million;
- HI PMI Crescltalia fund, for approximately Euro 20 million;
- Caravella fund, for Euro 15 million; and
- Oltre Il SICAF EuVECA S.p.A. fund, through the Social Impact Italia Platform, for Euro 7.5 million.

### B.3 Other investee companies

As at 31 December 2018, the carrying amount of other investee companies measured at FVOCI amounted to approximately Euro 414 million<sup>5</sup>.

| (thousands of euro)   | 31/12/2018        |                |           |                 |
|---|-------------------|----------------|-----------|-----------------|
|   | Investment sector | Account system | % holding | Carrying amount |
| <b>A. Equity Instruments</b>  |                   |                |           |                 |
| 1. QuattroR SGR S.p.A.  | Enterprises       | Separate       | -         | -               |
| <b>B. Investees</b>   |                   |                |           |                 |
| 1. F2i SGR S.p.A.   | Infrastructure    | Ordinary       | 14.01%    | 4,253           |
| 2. Istituto per il Credito Sportivo   | Infrastructure    | Separate       | 2.21%     | 19,904          |
| 3. Istituto Della Enciclopedia Italiana Fondata Da Giovanni Treccani S.p.A. | Culture           | Ordinary       | 7.42%     | 5,000           |
| 4. European Investment Fund   | Enterprises       | Separate       | 1.11%     | 21,977          |
| 5. Accialtalia S.p.A. in liquidation  | Industry          | Separate       | -         | -               |
| 6. Telecom Italia S.p.A.  | Telecommunication | Separate       | 4.93%     | 362,475         |
| <b>Total</b>  |                   |                |           | <b>413,608</b>  |

Apart from the cancellation of Accialtalia S.p.A. from the Companies' Register, amongst the main events occurring during the case of 2018, in April 2018, CDP purchased 750,000,000 ordinary shares of Telecom Italia S.p.A. – Italy's largest telecommunications provider – corresponding to 4.933 per cent. of the company's ordinary shares. This investment falls under CDP's institutional mission to support strategic national infrastructure and is aimed at supporting the growth and value enhancement launched by the company in a sector of primary interest for the country. The investment meets the economic-financial sustainability requirements that apply to all CDP's operations. As at 31 December 2018, the estimated fair value of the investment, based on the share price at 28 December 2018, was Euro 362 million, corresponding to a value of 0.48 euro per share.

### **CDP GROUP'S 2019 – 2021 BUSINESS PLAN**

On 5 December 2018, the Board of Directors of CDP approved its new Business Plan for the three-year period from 2019 to 2021 (the "**Business Plan**").

The Business Plan sets out the Group's objectives and strategies in light of the major economic and social challenges faced by Italy, the main global trends (innovation

<sup>5</sup> The portfolio also included equity instruments consisting of non-controlling interests acquired as part of the broader series of reorganisation transactions involving groups that operate in the energy sector. These financial instruments are recognised at fair value equal to zero.

and digitalization, energy transition and climate change, developing countries and international trade, social changes) and the Sustainable Development Goals of the UN 2030 Agenda.

The new Business Plan sets out a series of ambitious growth targets that the Group will also support with its own, entirely private, resources, consisting in postal savings bonds and passbook savings accounts and of resources raised on the national and international financial markets.

The increase in activity will be favoured by the development of the business model, thanks to CDP's progressively proactive approach aimed at providing effective acceleration, in sustainable terms, to the industrial and infrastructural development in Italy, as well as by the enhancement of the expertise and distinguishing features of CDP: protection of postal savings, long-term investment capacity, complementary role to the banking system and economic and financial balance.

#### Targets of the 2019-2021 Business Plan

With the new approved Business Plan, CDP intends to activate a total of Euro 203 billion between 2019 and 2021, contributing significantly to Italy's sustainable growth. It is a significant figure, which will be achieved by using 111 billion of its own resources and by activating Euro 92 billion of resources from private investors and other local and national institutions as well as supranational organisations.

All the planned actions will be achieved by ensuring economic and financial balance and, therefore, with full protection of the savings that families entrust to CDP through postal savings bonds and passbook savings accounts.

To effectively support the Italy's economic, social and environmental growth, CDP will deploy its actions over four main lines.

#### *CDP Enterprises*

The Business Plan will provide Euro 83 billion in new lending over the three-year period to encourage innovation and the international expansion of Italian companies, through the creation of a single Group offer and the simplification of the access channels. The aim is to expand the number of companies receiving support, with a target of 60,000 enterprises over the horizon of the Business Plan (reached either directly or indirectly, such as through the banking system), with a growing focus on SMEs.

The Group will provide enterprises with some dedicated tools for:

- innovation, with the development of medium-long term financing activities (complementary role to the banking system) - also with Italian and European resources, allowances and guarantees - and more incisive actions as regards venture capital, also through a dedicated asset management company and funds for incubators/accelerators;
- domestic and international growth, by expanding loans and direct guarantees for investments; strengthening the operations of the SACE Group in support of Italian exports (with a review of reinsurance and the introduction of new

digital products and “education on export” initiatives); reorganisation of equity instruments and the launch of sector-specific funds in areas such as mechanics, agribusiness and the white economy;

- facilitating the access of SMEs to direct finance, also through the involvement of other investors with tools such as regional basket bonds, and indirect finance, in collaboration with the banking system and through guarantees or national and European funds.

A new multichannel distribution model will be introduced: an enterprise will in fact have a single point of contact to access all the Group's products; the nationwide network will be expanded by providing at least one office in every Italian region; the digital channel and cooperation with third-party networks will also be strengthened to support small and medium-sized enterprises.

### *CDP Infrastructure, Public Sector and Local development*

The Business Plan will invest Euro 25 billion to support the local areas and authorities in building infrastructures and improving public utility services, by strengthening its partnership with the Public Administration and opening local offices.

With the aim of accelerating the development of infrastructures, a dedicated unit will be set up, called “CDP Infrastructures”, which will support Local Authorities in the project, development and financing of works. CDP will merge its traditional role of financial provider with that of promoter of new strategic projects, by involving industrial players in public-private partnership operations. The areas of intervention will be expanded, with a focus on mobility and transport, energy and networks and social and environmental aspects.

The Business Plan also envisages the following actions: enhanced cooperation with the Public Administration to relaunch investments and innovation, also through renegotiations and advances to facilitate access to national and European funds and the payment of debts to enterprises; the increase in direct intervention in local areas, with the launch of City Plans (*Piani Città*) for the upgrading of urban areas, and initiatives to support tourism (fund for the upgrading of tourist facilities, especially in the South), art and culture; the support for public services such as health (healthcare innovation and senior housing), housing (social housing) and education (student housing and student loans) services.

### *CDP Cooperation*

Euro 3 billion have been earmarked for carrying out projects in developing countries and emerging markets. The Business Plan also highlights a discontinuity in this area, with a proactive approach by CDP, which as manager of public resources, will assume the role of financing institution, capable of allocating resources through the identification of investment projects.

Loans will be granted to governments as well as to multilateral financial institutions such as development banks. CDP will also support enterprises by participating in Italian investment funds or those of the target countries which may also involve Italian industrial partners.

### *Strategic Equity Investments*

The Group's portfolio will be reorganised according to an industrial approach and by business sector, in order to support its development over the long term. The objective is threefold: to encourage the creation of industrial expertise in the strategic sectors of the production system; to support opportunities for cooperation between investee companies; to support the growth of the different enterprises that come within the value generation chains.

### *Sound capital base and protection of savings*

The new Business Plan sets out ambitious growth targets that put CDP at the heart of Italy's economic development and that will be pursued while relentlessly monitoring CDP's economic and financial balance.

CDP will continue with the expansion and diversification of its lending tools and with improvements to its risk hedging strategies related to the development in operations. In addition, it will continue its plan of renewal and development of postal savings bonds and passbook savings accounts, by extending the range of digital products and services, and the expansion of funding sources devoted to activities with social and environmental impact, such as social bonds, green bonds and sustainability bonds.

### *The new business model*

In order to achieve the targets of the Business Plan and in the light of the new business lines, an evolution in the business model is already in progress so as to respond effectively to the challenges of Italy. The new model involves various actions. One of these has already been launched and involves the strengthening of human capital, the Group's primary asset, with the attraction and development of talents. This process will be reinforced with the creation of an In-House Academy. There will also be a streamlining in the organisation and in the operational and decision-making processes, as well as the creation of customer-oriented solutions. Lastly, to this end, both CDP's offer and its communications with enterprises and the Public Administration will be digitalized.

### *CDP for Italy's sustainable development*

With its new Business Plan, CDP intends to contribute proactively towards the achievement of the Goals set by the United Nations 2030 Agenda, also signed by Italy. Sustainability will be integrated into CDP's choices through a gradual increase in lending to initiatives whose social and environmental impacts are clear and measurable. According to this approach, new assessment criteria for investments will be adopted for the first time that bring together the traditional economic and financial parameters with social and environmental aspects in order to minimise the Environmental Social and Governance (ESG) risk and maximise the positive impacts on communities and local areas. Sustainability, therefore, will no longer be a "side effect" resulting from CDP investments, which for over 160 years have produced positive aspects for Italy, but a founding pillar in its strategic business choices.

## CDP SHARE CAPITAL AND SHARE OWNERSHIP

The Issuer's authorised and fully paid in share capital, as at the date of this Base Prospectus, is equal to Euro 4,051,143,264.00 and is divided into 342,430,912 ordinary shares with no par value. As at the date of this Base Prospectus, the MEF owns 82.775 per cent. of the share capital of CDP and 15.925 per cent. is owned by 61 banking foundations (*fondazioni bancarie*). The remaining 1.3010 per cent. was repurchased by CDP after two banking foundations exercised their withdrawal right related to the conversion of preferred shares.

Pursuant to Article 5, paragraph 2, of Law Decree 269 and to article 7, paragraph 2, of CDP's by-laws, the majority of the shares with voting rights must be owned by the MEF. No shareholder of CDP, other than the MEF, may hold, directly or indirectly, shares equal to more than 5 per cent. of the share capital. Any voting rights attached to the shares held in excess of such shareholding, may not be exercised, without prejudice to the fact that the shares for which the right to vote may not be exercised will in any case be included in the calculation of the quorum required to constitute the shareholders' meeting. Pursuant to article 8, paragraph 1, of CDP's by-laws, shares may only be owned by the foundations referred to in Article 2 of Legislative Decree No. 153 of 17 May 1999, banks and supervised financial intermediaries, which fulfil the stability of assets and regular management requirements.

As at the date of this Base Prospectus, the shareholders of CDP are as follows:

| <b>Shareholders</b>                                   | <b>Share Capital Owned (%)</b> |
|---|--------------------------------|
| Ministero dell'economia e delle finanze (MEF)         | 82.775                         |
| Fondazione di Sardegna                                | 1.670                          |
| Compagnia di San Paolo                                | 1.609                          |
| Fondazione Cassa di Risparmio delle Province Lombarde | 1.558                          |
| Fondazione Cassa di Risparmio di Torino               | 1.500                          |
| Fondazione Cassa di Risparmio di Lucca                | 0.852                          |
| Fondazione Cassa di Risparmio di Trento e Rovereto    | 0.621                          |
| Fondazione Cassa di Risparmio di Cuneo                | 0.746                          |
| Fondazione Cassa di Risparmio di Firenze              | 0.601                          |
| Fondazione Cassa di Risparmio di Perugia              | 0.601                          |
| Fondazione Cassa di Risparmio di Padova e Rovigo      | 0.599                          |
| Fondazione di Venezia                                 | 0.417                          |
| Fondazione Banca del Monte di Lombardia               | 0.417                          |
| Fondazione Cassa dei Risparmi di Forlì                | 0.431                          |
| Fondazione Cassa di Risparmio di Genova e Imperia     | 0.371                          |
| Fondazione Cassa di Risparmio di Alessandria          | 0.371                          |
| Fondazione Cassa di Risparmio di Pistoia e Pescia     | 0.351                          |

| <b>Shareholders</b>   | <b>Share Capital<br/>Owned (%)</b> |
|---|------------------------------------|
| Fondazione Agostino De Mari   | 0.275                              |
| Fondazione Cassa di Risparmio di Trieste                            | 0.256                              |
| Fondazione di Piacenza e Vigevano                                   | 0.029                              |
| Fondazione Cassa di Risparmio di Ravenna                            | 0.167                              |
| Istituto Banco di Napoli Fondazione                                 | 0.142                              |
| Fondazione Friuli   | 0.136                              |
| Fondazione Cassa di Risparmio della Spezia                          | 0.109                              |
| Fondazione Cassa di Risparmio della Provincia di Macerata           | 0.100                              |
| Fondazione Cassa di Risparmio di Bolzano                            | 0.089                              |
| Fondazione Cassa di Risparmi di Livorno                             | 0.089                              |
| Fondazione Cassa di Risparmio di Gorizia                            | 0.083                              |
| Fondazione Cassa di Risparmio di Modena                             | 0.149                              |
| Fondazione Cassa di Risparmio della Provincia dell'Aquila           | 0.083                              |
| Fondazione Cassa di Risparmio di Terni e Narni                      | 0.083                              |
| Fondazione Cassa di Risparmio di Asti                               | 0.083                              |
| Fondazione Cassa di Risparmio di Imola                              | 0.086                              |
| Fondazione Cassa di Risparmio di Carpi                              | 0.083                              |
| Fondazione Cassa di Risparmio di Biella                             | 0.083                              |
| Fondazione Cassa di Risparmio di Reggio Emilia - Pietro Manodori    | 0.083                              |
| Fondazione Cassa di Risparmio della Provincia di Teramo             | 0.083                              |
| Fondazione Cassa di Risparmio di Pesaro                             | 0.067                              |
| Fondazione Pescaraabruzzo   | 0.042                              |
| Fondazione Cassa di Risparmio di Mirandola                          | 0.033                              |
| Fondazione del Monte di Bologna e Ravenna                           | 0.033                              |
| Fondazione Cassa di Risparmio di Vercelli                           | 0.033                              |
| Fondazione Cassa di Risparmio della Provincia di Viterbo CA.RI.VIT. | 0.033                              |
| Fondazione Banca del Monte di Lucca                                 | 0.013                              |
| Fondazione Sicilia  | 0.033                              |
| Fondazione Cassa di Risparmio di Calabria e di Lucania              | 0.025                              |
| Fondazione dei Monti Uniti di Foggia                                | 0.025                              |
| Fondazione Cassa di Risparmio di Fabriano e Cupramontana            | 0.033                              |
| Fondazione Cassa di Risparmio di Saluzzo                            | 0.033                              |
| Fondazione Cassa di Risparmio di Savigliano                         | 0.019                              |



| <b>Shareholders</b>                                     | <b>Share Capital Owned (%)</b> |
|---|--------------------------------|
| Fondazione Cassa di Risparmio di Fossano                | 0.017                          |
| Fondazione Cassa di Risparmio di Carrara                | 0.017                          |
| Fondazione Cassa di Risparmio di Fermo                  | 0.017                          |
| Fondazione Cassa di Risparmio di Orvieto                | 0.019                          |
| Fondazione Cassa di Risparmio e Banca del Monte di Lugo | 0.017                          |
| Fondazione Cassa di Risparmio Salernitana               | 0.017                          |
| Fondazione Cassa di Risparmio di Spoleto                | 0.017                          |
| Fondazione Cassa di Risparmio di Volterra               | 0.016                          |
| Fondazione Cassa di Risparmio di Ferrara                | 0.014                          |
| Fondazione Banca del Monte e C.R. Faenza                | 0.008                          |
| Fondazione Banca del Monte di Rovigo                    | 0.002                          |
| Fondazione CARIPARMA                                    | 0.330                          |
| CDP – Own shares  | 1.300                          |

## ***CDP ADMINISTRATIVE, MANAGEMENT AND SUPERVISORY BODIES***

### ***Board of Directors, Managing Director and General Manager***

The shareholders' meeting held on 24 July 2018 elected a new Board of Directors for the 2018, 2019 and 2020 financial years, appointing as directors: Massimo Tononi (Chairman), Luigi Paganetto (Vice Chairman), Fabrizio Palermo (Chief Executive Officer and General Manager), Francesco Floro Flores, Valentino Grant, Fabrizia Lapecorella, Fabiana Massa, Matteo Melley and Alessandra Ruzzu.

On 27 July 2018, the Board of Directors appointed Luigi Paganetto as Vice Chairman and Fabrizio Palermo as Chief Executive Officer.

On 4 October 2018, the Board of Directors appointed Fabrizio Palermo as General Manager in addition to his current role as Chief Executive Officer and on 30 October 2018 appointed Alessandro Tonetti as Vice General Manager in addition to his current role as Chief Legal Officer.

Pursuant to CDP's by-laws, the Board of Directors is composed of nine members, elected for a period of no more than three financial years. They may be re-elected.

As at the date hereof, the members of the Board of Directors are:

|                        |  |
|------------------------|--|
| Massimo Tononi         | <i>(Chairman)</i>                                    |
| Luigi Paganetto        | <i>(Vice Chairman)</i>                               |
| Fabrizio Palermo       | <i>(Chief Executive Officer and General Manager)</i> |
| Francesco Floro Flores |  |
| Valentino Grant        |  |
| Fabrizia Lapecorella   |  |

Fabiana Massa  
Matteo Melley  
Alessandra Ruzzu

Pursuant to article 15 of CDP's by-laws, for matters relating to the Separate Account System (as described above), the Board of Directors consists of the members listed in letters (c), (d) and (f) of Article 7, paragraph 1, of Law 197 (the "**Additional Directors**").

As at the date hereof, the Board of Directors consists of the following Additional Directors:

|                       |   |
|-----------------------|---|
| Pierpaolo Italia      | <i>(Delegate of the State Accountant General)</i> |
| Alessandro Rivera     | <i>(General Director of the Treasury)</i>         |
| Davide Carlo Caparini |   |
| Antonio Decaro        |   |
| Achille Variati       |   |

In addition to their respective positions held within CDP, as at the date hereof, the Directors listed below hold the following offices outside CDP:

|                        |   |
|------------------------|---|
| Massimo Tononi         | Chairman of CDP Reti S.p.A.   |
| Luigi Paganetto        | No significant offices  |
| Fabrizio Palermo       | Chief Executive Officer of CDP Reti S.p.A.<br>Member of the Board of Directors of Fincantieri S.p.A.<br>Chairman of CDP Equity S.p.A.   |
| Francesco Floro Flores | Member of the Board of Directors of Trefin S.p.A.<br>Member of the Board of Directors of 3F&EDIN S.p.A.<br>Member of the Board of Directors of Aerosoft S.p.A.<br>Member of the Board of Directors of NAUTICAD S.r.l.<br>Chairman of the Board of Directors of Consorzio Citema<br>Chairman of the Board of Directors of Consorzio Tecneva<br>Chairman of the Board of Directors of Aerosoft France sas<br>Chairman of the Board of Directors of Aerosoft Technologie GmbH<br>Extraordinary Commissioner of the Italian Government for the Environmental Remediation and Urban Regeneration of the Area of Significant National Interest of Bagnoli-Coroglio. |
| Valentino Grant        | Chairman of the Board of Directors of Banca di Credito Cooperativo Terra di Lavoro "S. Vincenzo de' Paoli" S.c.p.a.   |
| Fabrizia Lapecorella   | General Director of the Finance Department, Ministry of Economy and Finance   |

|                       |   |
|-----------------------|---|
| Fabiana Massa         | University Professor  |
| Matteo Melley         | Chairman of Fondazione Carispezia<br>Chairman of the Board of Directors of CDP Immobiliare S.r.l.   |
| Alessandra Ruzzu      | No significant offices  |
| Alessandro Rivera     | General Director of the Treasury Department,<br>Ministry of Economy and Finance<br>Chairman of the Board of Directors of SGA S.p.A.<br>Member of the Supervisory Board of<br>STMicroelectronics |
| Pierpaolo Italia      | No significant offices  |
| Davide Carlo Caparini | Liquidator of Celticon S.r.l.<br>Liquidator of Media Padania S.r.l.<br>Member of the Board of Directors of AIFA ( <i>Agenzia Italiana del farmaco</i> )   |
| Antonio Decaro        | Chairman of Associazione Nazionale Comuni Italiani (ANCI)   |
| Achille Variati       | Mayor of the city of Bari<br>No significant offices   |

No conflict of interest exists between duties owed to the Issuer by the members of the Board of Directors, as listed above, and their private interests.

The business address of the members of the Board of Directors is at CDP's registered office at Via Goito 4, 00185 Rome, Italy.

The Chairman of the Board of Directors is the legal representative of CDP and is authorised to sign on its behalf, to chair shareholders' meetings and to convene and chair the Board of Directors. The Vice-Chairman will substitute for the Chairman in case of his/her absence or inability. The Chief Executive Officer is the legal representative of CDP in respect of the powers vested in him by the Board of Directors.

Directors are elected through the voting list system; only the shareholders who represent, alone or together with other shareholders, at least 10 per cent. of shares with voting rights in the ordinary shareholders' meeting have the right to present a list. The first candidate on the list which obtains the greatest number of votes is appointed Chief Executive Officer, while the first candidate on the list which obtains the second greatest number of votes is appointed Chairman. Unless already done by the shareholders' meeting, the Board of Directors elects a Chairman; furthermore, the Board of Directors elects a Vice-Chairman and appoints a Secretary and a Vice-Secretary.

The majority of the directors in office shall be present at a meeting in order for the Board of Directors to pass valid resolutions at such meeting, without prejudice to the provisions of article 30, paragraph 3, of CDP's by-laws, and for the adoption of the resolutions referred to in article 21, paragraph 1, letter (m) and article 21, paragraph 2, of CDP's by-laws, which are adopted in the presence of at least seven directors elected by the shareholders' meeting.

Resolutions shall be passed by the majority of the directors attending and voting in favour, without prejudice to the provisions of article 30, paragraph 3, of CDP's by-laws, and for the adoption of the resolutions referred to in article 21, paragraph 1, letter (m) and article 21, paragraph 2, of CDP's by-laws, which are adopted in the presence of at least seven directors elected by the shareholders' meeting.

Resolutions concerning the Separate Account System shall be passed by the favourable vote of at least two of the Additional Directors attending the meeting. In the event of a tied number of votes, the vote of the Chairman of the meeting prevails.

In addition to the matters reserved to the Board of Directors by law, the following matters, among others, fall within its exclusive authority: (a) the set-up of the strategic policies of CDP and the approval of related plans; (b) the determination of CDP's general organisational structure; (c) any appointment and determination of the powers of a General Manager and one or more Deputy General Managers and the dismissal of such officers, having obtained the opinion of the Chief Executive Officer; (d) the determination of the operative terms and conditions for implementing the guidelines issued by the Bank of Italy; (e) the acquisition or transfer of shareholdings; (f) the granting of loans in amounts exceeding Euro 500,000,000.00; (g) the borrowing of amounts exceeding Euro 500 million; (h) the creation of separate assets; (i) the setting up of administrative and representative branches and representative and executive offices, both in Italy and abroad; (j) the determination of the operative terms and conditions for implementing the guidelines of the Separate Account System; and (k) the establishment of risk objectives, of any tolerance thresholds and risk governance and management policies and the associated risk detection procedures, which shall be specified in appropriate rules.

### ***Board of Statutory Auditors***

The board of statutory auditors of CDP (the "**Board of Statutory Auditors**") is composed of five effective auditors and two alternate auditors. The auditors are appointed in compliance with Italian law and regulations by the shareholders' meeting for a term of three years and may be re-elected.

As at the date hereof, the members of the Board of Statutory Auditors are:

|                      |                              |
|----------------------|------------------------------|
| Carlo Corradini      | ( <i>Chairman</i> )          |
| Luciano Barsotti     | ( <i>Effective auditor</i> ) |
| Giusella Finocchiaro | ( <i>Effective auditor</i> ) |
| Ines Russo           | ( <i>Effective auditor</i> ) |
| Alessandra dal Verme | ( <i>Effective auditor</i> ) |
| Giandomenico Genta   | ( <i>Alternate auditor</i> ) |
| Angela Salvini       | ( <i>Alternate auditor</i> ) |

In addition to their respective offices held at CDP, as at the date hereof, the members of the Board of Statutory Auditors listed below hold the following offices:

|                      |   |
|----------------------|---|
| Carlo Corradini      | <p>Chairman of Banor Sim</p> <p>Member of the Board of Directors of PLT Energia S.p.A.</p> <p>Member of the Board of Directors of Quaestio Capital Management SGR</p> <p>Member of the Board of Directors of Quaestio Holding S.A.</p> <p>Member of the Board of Directors of YLF S.p.A.</p> <p>Sole Director of Corradini &amp; C</p>  |
| Alessandra dal Verme | <p>Chairman of the Board of Statutory Auditors of A.D.R.</p> <p>Chairman of the Board of Statutory Auditors of Consip S.p.A.</p>  |
| Ines Russo           | No significant offices  |
| Giusella Finocchiaro | Chairman of Fondazione del Monte di Bologna e Ravenna   |
| Luciano Barsotti     | No significant offices  |
| Angela Salvini       | <p>Member of the Board of Auditors of Federazione Italiana Golf</p> <p>Chairman of the Board of Statutory Auditors of SACBO S.p.A.</p> <p>Chairman of the Board of Auditor at ONFA (Opera Nazionale per i Figli degli Aviatori)</p>   |
| Giandomenico Genta   | <p>Chairman of the Board of Statutory Auditors of:</p> <ul style="list-style-type: none"> <li>- Finanziaria Sviluppo Impresa S.p.A.</li> <li>- Autostrade per l'Italia S.p.A.</li> </ul> <p>Member of the Board of Statutory Auditors of:</p> <ul style="list-style-type: none"> <li>- Italgas S.p.A.</li> <li>- EsseDiesse S.p.A.</li> <li>- Società Italiana per Azioni per il Traforo del Monte Bianco</li> <li>- Rav Raccordo Autostradale Valle d'Aosta S.p.A.</li> </ul> <p>Chairman of the Board of Directors of:</p> <ul style="list-style-type: none"> <li>- Satispay S.p.A.</li> <li>- Fondazione Cassa di Risparmio di Cuneo</li> </ul> <p>Member of the Board of Directors of:</p> <ul style="list-style-type: none"> <li>- Fondazione Con il Sud</li> <li>- Equiter S.p.A.</li> <li>- F2i SGR S.p.A.</li> <li>- REAM SGR S.p.A.</li> </ul> |

Statutory auditors are elected by the same voting list system as the one applicable to the election of Directors. The Chairman of the Board of Statutory Auditors shall be the first candidate elected from the list which obtained the greatest number of votes.

The business addresses of the member of the Board of Statutory Auditors are specified below:

|                      |                         |
|----------------------|-------------------------|
| Carlo Corradini      | Via Goito 4, 00185 Rome |
| Alessandra dal Verme | Via Goito 4, 00185 Rome |
| Ines Russo           | Via Goito 4, 00185 Rome |
| Giusella Finocchiaro | Via Goito 4, 00185 Rome |
| Luciano Barsotti     | Via Goito 4, 00185 Rome |
| Angela Salvini       | Via Goito 4, 00185 Rome |
| Giandomenico Genta   | Via Goito 4, 00185 Rome |

### ***Court of Accounts' supervision***

Pursuant to Article 5, paragraph 17, of Law Decree No. 269, CDP is supervised by the Italian Court of Accounts (*Corte dei Conti*) in accordance with Article 12 of Law No. 259 of 21 March 1958. The supervision is exercised by one of the Court of Accounts' members, appointed by the Court's President, who is entitled to attend the meetings of the Board of Directors and of the Board of Statutory Auditors. The member of the Court of Accounts who is currently in office for CDP's supervision is Angelo Buscema, while Giovanni Comite is the alternate member.

### ***Auditing Firm***

Upon proposal of the Board of Directors and having consulted with the Board of Statutory Auditors, an auditing firm was appointed for a period of nine years during the shareholders' meeting of 25 May 2011.

The auditing firm appointed by CDP is PricewaterhouseCoopers S.p.A., with registered offices at Via Monte Rosa 91, Milan, Italy, whose term of office will expire upon approval of the financial statements for the year 2019.

PricewaterhouseCoopers S.p.A. is a company enrolled with the Register of Certified Auditors (Registro dei Revisori Legali) held by the MEF.

### ***Committee of Minority Shareholders***

Pursuant to article 22 of CDP's by-laws, the committee of minority shareholders of CDP (the "**Committee of Minority Shareholders**") is composed of nine members appointed by the minority shareholders. The committee shall be appointed with the quorums to convene and to deliberate as provided by the regulations applicable to the ordinary shareholders' meeting and its term shall end on the date of the shareholders' meeting convened to appoint the Board of Directors. The Committee of Minority Shareholders appoints a chairman who has the power to convene the meetings, to set the agenda and to chair the meetings. The chairman receives in advance from CDP analytical reports on the (i) level of financial liquidity, (ii) lending commitments, (iii) shareholdings and participations, (iv) current and prospective investments, (v) most relevant business transactions entered into by CDP, (vi) updated accounting information, (vii) the auditing company's reports and the internal auditing reports relating to the organisation and to the functioning of CDP and (viii) minutes of the Board of Statutory Auditors.

The chairman may request additional information from the Chairman of the Board of Directors, from the Chief Executive Officer, from the General Manager, where appointed, or from the Chairman of the Board of Statutory Auditors. The minutes of the Committee of Minority Shareholders are notified to the Board of Directors and the Board of Statutory Auditors. The members of the committee are subject to a duty of confidentiality with respect to the information on business activities provided by CDP.

As at the date hereof, the members of the Committee of Minority Shareholders are the following:

Giovanni Quaglia (Chairman)

Konrad Bergmeister

Marcello Bertocchini

Giampietro Brunello

Paolo Cavicchioli

Federico Delfino

Francesco Profumo

Enrica Salvatore

Sergio G.G.E.W. Zinni

Parliamentary Supervisory Committee

The Parliamentary Supervisory Committee of CDP (the "Parliamentary Supervisory Committee") is composed of four members of the Italian Senate (Senato della Repubblica), four members of the Italian Chamber of Deputies (Camera dei Deputati), three judges of the Council of State (Consiglio di Stato), and one judge of the Court of Accounts (Corte dei Conti). Pursuant to Article 5, paragraph 9 of Law Decree No. 269 and Royal Decree No. 453, the Parliamentary Supervisory Committee supervises the Separate Account System of CDP.

The Parliamentary Supervisory Committee for the 18<sup>th</sup> Legislature must still be constituted. As at the date hereof, it is currently in charge of the Committee appointed for the 17<sup>th</sup> Legislature, pursuant to the combined provisions of article 14 of the d.lgt. 23 March 1919 n. 1058 and article 3 of the R.D. 2 January 1913, n. 453.

Therefore, the members of the Parliamentary Supervisory Committee are the following:

|   |                  |
|---|------------------|
| Anna Cinzia Bonfrisco ( <i>Chairman</i> ) | Senate           |
| Bruno Astorre                             | Senate           |
| Stefano Fantini                           | Council of State |
| Pancrazio Savasta                         | Council of State |

***Parliamentary Supervisory Committee pursuant to Article 56 of Law No. 88 of 9 March 1989 ("Law 88")***

Article 1, paragraph 253, of the Stability Law 2014 has conferred to the Parliamentary Supervisory Committee for the "oversight of entities managing mandatory pension and welfare services" – established by Law 88 – the specific task of supervising the Separate Account System of CDP, with respect to the financial operations and the operations supporting the public sector achieved in the pension and welfare field.

***Supervisory Board pursuant to Legislative Decree No. 231 of 8 June 2001 ("Decree 231")***

CDP established a supervisory board in compliance with Decree 231 for the purpose of monitoring the risks of potential criminal and administrative liabilities (the "**Supervisory Board**"). Decree 231 established the criminal and administrative liability of a corporation in the event that an employee violates criminal provisions in the interest and for the benefit of the corporation. For the purpose of avoiding and reducing the risk of such liability, Decree 231 requires corporations to adopt an organisational model in order to monitor business activities and internal procedures in order to prevent any kind of violation.

Pursuant to Article 6, paragraph 4-*bis*, of Decree 231 and in accordance with the Bank of Italy regulations in force, the meeting of the Board of Directors, held on 25 January 2017, resolved to transfer all the functions and duties of the previously appointed Supervisory Board to the Board of Statutory Auditors, with effect from 27 February 2017.

The activity of the Board of Statutory Auditors acting as Supervisory Board is supported by the Chief Audit Officer structure of CDP (See "*Internal Controls*" below).

***Board committees***

The following are brief descriptions of the board committees of CDP which have been set up for the specific purpose of providing support to CDP's management in either an advisory capacity or by making proposals for the consideration of the entire Board of Directors. Such committees are: (i) the Strategic Committee; (ii) the Risk Committee; (iii) the Related Parties Committee; and (iv) the Compensation Committee.



### *Strategic Committee*

The Strategic Committee is established, pursuant to article 20, paragraph 2, of CDP's by-laws, within the Board of Directors and is composed of the Chairman, the Vice-Chairman and the Chief Executive Officer. The Strategic Committee supports the organisation and coordination of the Board of Directors and supports the strategic oversight of the activities of the company. The Strategic Committee meets at least once a month and in any case before each Board of Directors' meeting.

As at the date hereof, the Strategic Committee is composed of the following members: Massimo Tononi (Chairman), Luigi Paganetto and Fabrizio Palermo.

### *Risk Committee*

The Risk Committee is established, pursuant to article 21, paragraph 2, of CDP's by-laws, by the Board of Directors and is chaired by the Vice-Chairman of the Board of Directors. In addition to the Vice-Chairman, the Risk Committee shall be composed by at least two and up to a maximum of three members of the Board of Directors elected by the shareholders' meeting. The Risk Committee has responsibility over the control and development of policy recommendations in the field of risk management and for the assessment of the adoption of new products. The Chief Risk Officer and the Chief Audit Officer of CDP attend the Committee's meetings.

As at the date hereof, the Risk Committee is composed of the following members: Luigi Paganetto (Chairman), Fabrizia Lapecorella, Fabiana Massa and Matteo Melley.

### *Related Party Committee*

The Related Party Committee is appointed by the Board of Directors and is composed of three non-executive directors. The committee's role is to analyse related party transactions and to produce a preliminary report thereon, setting out whether it is in CDP's interest to carry out such transaction, how CDP will benefit from the same, and evaluating whether the conditions applicable to the transaction are substantially and procedurally correct.

As at the date hereof, the Related Party Committee is composed of the following members: Fabiana Massa (Chairman), Valentino Grant and Alessandra Ruzzu.

### *Compensation Committee*

The Compensation Committee is appointed by the Board of Directors and is composed of three non-executive directors. The committee is tasked with assisting in the evaluation of the compensation of the Chairman, the Chief Executing Officer and the General Manager and, where possible, of the other administrative bodies of the company required by law or by virtue of CDP's by-laws, including those established by the Board of Directors (i.e. the committees). The proposals made by the Compensation Committee are submitted for the approval of the Board of Directors, upon prior opinion of the Board of Statutory Auditors.

As at the date hereof, the Compensation Committee is composed of the following members: Fabrizia Lapecorella (Chairman), Francesco Floro Flores and Alessandra Ruzzu.

### ***Internal controls, risk management and compliance***

CDP has developed an internal control framework consisting of a set of rules, procedures, and organisational structures aimed at ensuring compliance with the applicable regulations, in accordance with its corporate strategies and the achievement of targets set by company management.

In particular, CDP has implemented the internal control system according to the three lines of defence model. The so-called "first level controls" (line controls) are carried out by business departments, including the back office department and, where possible, are correlated by IT procedures. These controls are detailed in internal written procedures and are designed to ensure that transactions are carried out correctly.

The so-called "second level controls" (risk management and compliance controls) are carried out by dedicated and independent departments that are not in charge of front office activities, i.e. the risk management function, the compliance function and the anti-money laundering function. According to the relevant regulations and best practices, these independent, separate and permanent second level functions are both under the direction of an independent Chief Risk Officer.

The risk management controls are designed, inter alia, to establish risk measurement methodologies and to verify that the operational limits set for the different areas are respected, as well as to ensure coherence between the risks taken by the business departments and the risk policy approved by the Board of Directors.

Three Risk Committees are established: (i) the Board of Directors Risk Committee which comprises members of the Board of Directors and supports the Board of Directors regarding risks and the system of internal controls; (ii) the Internal Risk Committee, in support of the Chief Executive Officer, which has responsibilities for controlling and formulating proposals concerning risk management matters and the evaluation of the adoption of new products; and (iii) a Group Risk Committee, which is responsible for the CDP Group governance in risk management matters.

In addition, so called "second level controls" (compliance controls) are carried out by the CDP compliance function. The CDP compliance function ensures, on a risk-based approach, the compliance risk management, which can be defined as the risk of legal or administrative sanctions, financial loss, or reputational risk a company may suffer as a result of its failure to comply with all applicable laws and regulations or self-regulatory arrangements (i.e. codes of conduct, codes of ethics, internal procedures).

The primary duties of the compliance function include:

- identifying, on an ongoing basis, the relevant laws and regulations applicable to CDP and assessing the related impact on the internal processes and procedures, and more generally, within the whole organisation;

- identifying the appropriate internal procedures in order to manage the compliance risk and verifying its effectiveness and adequacy;
- making proposals related to organisational and procedural changes in order to ensure that compliance risks identified are managed appropriately;
- reporting appropriately and periodically to the governing bodies and corporate structures involved;
- verifying the effectiveness and adequacy of the organisational measures suggested to manage compliance risk; and
- coordinating the compliance functions of the companies controlled (*direzione e coordinamento*) by CDP, in order to guarantee an integrated management of the risk of non-compliance within the CDP Group.

The compliance function, on an ongoing basis, prevents reputational risk in order to ensure the protection of the CDP Group's reputation according to the risk appetite framework established by the Board of Directors.

Furthermore, pursuant to Italian Decree No. 231 of 21 November 2007 ("**Decree 231/2007**") and the measures issued by the Bank of Italy, CDP appointed the head of the Compliance and Anti-Money Laundering Area as the company's legal representative concerning anti-money laundering compliance. As a result, the Compliance and Anti-Money Laundering Area includes a separate anti-money laundering function. Such function carries out additional controls in order to appropriately know the relevant "customers" involved in transactions with CDP as well as any suspicious transactions and promptly inform the supervisory authority.

Finally, the so-called "third level controls" are performed by the Internal Audit department, a permanent, independent and objective function, under the direction of an independent Chief Audit Officer, that reports hierarchically to the Board of Directors, through its Chairman.

The Internal Audit department, through professional and systematic supervision, pursues the continuous improvement of the effectiveness and efficiency of governance, risk management and control processes of CDP and Group subsidiaries subject to management and coordination. Specifically, the Internal Audit department provides an independent and objective evaluation of the completeness, adequacy, functionality and reliability of the organisational structure and of the overall system of internal controls of the CDP Group, and it assesses the regular functioning of processes, the safeguard company and investor assets, the reliability and integrity of accounting and management information as well as compliance with internal and external regulations and management guidelines.

For the execution of its activities, annually the Internal Audit department prepares, and presents to the Board of Directors an audit plan for its approval. The Audit Plan is consistent with the reference regulation, the risks associated with the activities run for the achievement of the corporate goals, as well as the guidelines provided by the corporate bodies. It sets out the activities to be carried out and the objectives to be pursued.

The Internal Audit department reports to the Board of Directors and the Board of Statutory Auditors on a quarterly basis on the activities carried out, the main issues detected and the progress of corrective actions taken, regarding CDP and Group subsidiaries subject to management and coordination, after examination by the Board of Directors Risk Committee. Annually, it also prepares an overall opinion on the reliability of the Internal Control System. The issues identified during each audit engagement are immediately reported to the relevant company units so that they can implement corrective actions.

The audit activities of the subsidiaries subject to management and coordination are carried out in close coordination with CDP, which in many several cases also acts as an outsourcer on the basis of specific service agreements. The Internal Audit department also assists the supervisory body (in CDP and in the subsidiaries) established pursuant to Decree No. 231/2001 in carrying out its work.

Furthermore, the Internal Audit department may provide advisory services to other corporate functions in order to create added value and to improve the management of risks and the organisation's efficiency, without taking management responsibilities to avoid any situation of potential conditioning of its independence and objectivity.

Finally, the Internal Audit department regularly monitors the effectiveness of anti-money laundering and terrorist financing controls, as well as the effectiveness of the internal capital adequacy assessment process.

## **EMPLOYEES**

As at the date hereof, CDP has 797 employees.

## **ORGANISATIONAL STRUCTURE**

As of the date hereof, CDP's internal organisation is structured as follows.

The following structures report to the Board of Directors: Chief Executive Officer & General Manager; Chief Audit Officer.

The following divisions report to the Chief Executive Officer & General Manager: Deputy General Manager and Chief Legal Officer; Chief External Relations & Sustainability Officer; Chief Operating Officer; Chief Risk Officer; Chief Financial Officer; Chief Investments Officer; CDP Corporate; CDP Infrastructures and Public Sector; CDP Development Finance; Public Affairs.

The Chief Audit Officer is in charge of managing the following scope of business: audit execution, group audit coordination, audit methodologies, Supervisory Body support.

The Deputy General Manager and Chief Legal Officer is in charge of managing the following scope of business: business legal support; finance and equity investments legal support; litigations; corporate and regulatory affairs; group governance.

The Chief Operating Officer is in charge of managing the following scope of business: procurement; ICT; human resources; logistics; organization; back office.

The Chief Risk Officer is in charge of managing the following scope of business: compliance; anti-money laundering; risk operations; risk management.

The Chief Financial Officer is in charge of managing the following scope of business: administration; financial statement and controls; regulatory reporting; finance and funding; tax; planning and control; investor relations.

CDP Corporate is in charge of managing financial support to Italian enterprises at both national and international level.

CDP Infrastructures and Public Sector is in charge of managing financial support to infrastructure players and national and local public entities.

CDP Development Finance is in charge of managing financial support to developing countries and emerging markets.

The Chief Investments Officer is in charge of managing the following scope of business: mergers and acquisitions in equity investments, funds and venture capital.

The Chief External Relations and Sustainability Officer is in charge of managing the following scope of business: communications; institutional relations; sustainability.

Public Affairs is in charge of managing the following scope of business: European and international affairs.

In managing business activities and priorities, as well as significant corporate and Group strategic projects, the Chief Executive Officer and General Manager is supported by the Organisational Unit Technical Secretary & Special Projects.

Accordingly, the organisational structure of CDP is set out in the chart below.

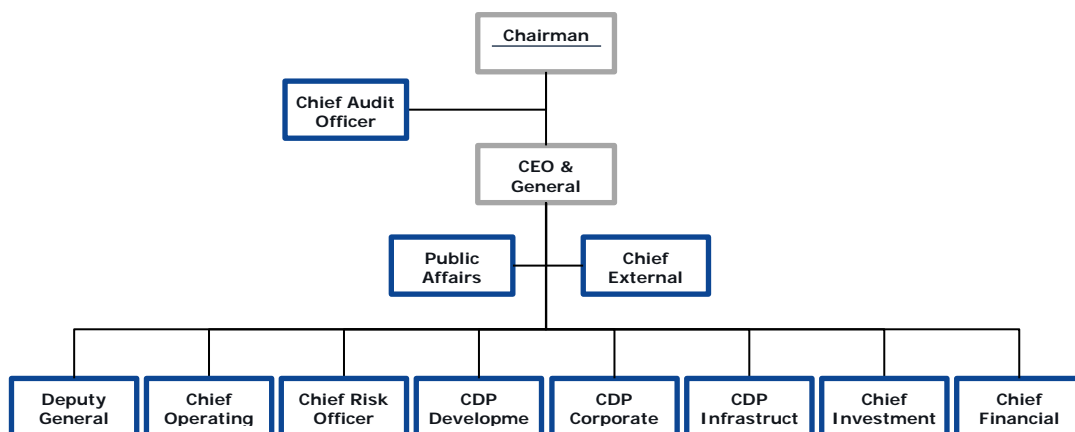

## **CORPORATE GOVERNANCE**

CDP complies with Italian laws and regulations regarding corporate governance.

## **MATERIAL CONTRACTS**

The Issuer has not entered into any material contracts during the years 2018 and 2017 outside of its ordinary course of business that have been or may reasonably be expected to be material to the Issuer's ability to meet its obligations to the Noteholders.

## **RECENT EVENTS**

### ***Strengthening of the Telecom Italia S.p.A.'s shareholding***

On 14 February 2019, the Board of Directors of CDP authorised the purchase of further shares in Telecom Italia S.p.A.

Such investment is in line with the strategic objectives underlying the decision to strengthen CDP's stake in the share capital of Telecom Italia S.p.A. as approved by the Board of Directors on 5 April 2018, and is consistent with CDP's institutional mission to support national strategic infrastructure and is also aimed at supporting the development and value creation process that CDP has commenced in a sector of primary interest for Italy.

## **LEGAL PROCEEDINGS**

### ***Legal disputes of the Issuer***

Currently, CDP is a party in civil and administrative proceedings and legal actions connected with the normal course of its operations.

As at 31 December 2018, CDP was subject to 72 civil and administrative legal proceedings (of which 17 related to employment disputes). Excluding the aforementioned employment disputes, the total value of the claims was approximately Euro 850 million. Accordingly, CDP has set aside a prudential reserve of Euro 33 million which it considers adequate to cover risks related to the possible negative outcomes of such proceedings.

The main pending lawsuit was filed before the Court of Rome by the Fondazione Cassa di Risparmio di Verona, Vicenza, Belluno e Ancona (the "**Fondazione Cariverona**") in 2013 and concerns the conversion of preference shares into ordinary shares following the exercise of a right of withdrawal. The claim, which originally amounted to approximately Euro 432 million, has been increased to Euro 651 million according to the request included in the final brief filed by the Fondazione Cariverona for the specification of the conclusions. The dispute is currently pending (i) before the Court of Rome, in relation to Fondazione Cariverona's main claims and (ii) before the Court of Appeal of Rome, in relation to the preliminary objections raised by CDP in the first instance proceedings and rejected by the Court of Rome. In relation to the item (i) proceedings before the Court of Rome, the risk of losing the dispute is considered to be probable. However, given the peculiarity and complexity of the dispute and its current status, no prudential reserve has been set aside in

accordance with the applicable accounting policies. In connection with the item (ii) proceedings pending before the Court of Appeal of Rome, the risk of losing the dispute is considered to be possible. In any case, the outcome of the proceedings overall is expected to be favourable.

As far as employment disputes are concerned, as at 31 December 2018, the total estimated liability was approximately Euro 6 million and the appropriate reserves was approximately Euro 3 million.

### **Legal disputes concerning some CDP's subsidiaries**

#### **SACE**

As at 31 December 2018, SACE was involved in eleven passive disputes relating to insurance commitments (for a total value of Euro 18.4 million), the majority of which arose prior to 2003, *i.e.* before SACE's transformation in a joint stock company, and in three minor disputes with suppliers (for a total value of Euro 0.9 million). SACE was also involved in eight active litigations (for a total value of Euro 170.4 million, which includes a recovery action against the Hungarian Republic for Euro 150 million) as well as in a further sixty bankruptcy proceedings relating to the recognition of the right of preference pursuant to Legislative Decree No. 123 of 31 March 1998. Lastly, SACE was also involved in four labour disputes.

In relation to SACE's subsidiaries, the insurance company SACE BT S.p.A. was involved in 181 passive disputes concerning insurance matters (for a total value of Euro 77.8 million), eight generic cases against former agents and suppliers (for a total value of Euro 1.7 million), four active litigations (for a total value of Euro 11.8 million) and one labour dispute.

The factoring company SACE Fct S.p.A. was involved in four passive disputes (total value of Euro 1 million), several active litigations (for a total value of Euro 94 million) and further extra-judicial recovery actions (for a total value of Euro 18 million).

#### **SIMEST**

As at 31 December 2018, SIMEST was involved in two employment disputes for a total potential claim amount of approximately Euro 0.28 million.

As at 31 December 2018, SIMEST was involved in one passive civil judicial dispute against Costa Ferroviaria S.p.A. subject to extraordinary administration, for a total value of Euro 0.7 million. SIMEST is also involved in 83 active civil disputes for credit recovery.

#### **CDP Immobiliare**

As at 31 December 2018, CDP Immobiliare was involved in 70 civil and administrative disputes. 54 claims directly involved CDP Immobiliare and 16 involved its subsidiaries.

The disputes mainly concern the management of the real estate assets of CDP Immobiliare and its subsidiaries. Such disputes are, *inter alia*, related to: (i) the release of illegally occupied buildings; (ii) eviction or finished lease proceedings; (iii)

the ascertainment of property or rights; (iv) the deeds of sale of real estate assets; (v) compensation for pecuniary damage for contractual and/or pre-contractual liability; and (vi) the collection of unpaid receivables. Finally, there are also administrative disputes aimed at voiding acts and measures of the public administration, and some criminal proceedings.

The estimated total potential liability amounts to approximately Euro 57 million. Accordingly, CDP immobiliare has set aside a prudential reserve of Euro 6.6 million to cover risks related to the possible or probable negative outcomes of these proceedings, while the subsidiaries have set aside a prudential reserve of Euro 60 thousand. This reserve refers to the proceedings of CDP Immobiliare and its subsidiaries, except for tax and labour proceedings.

As at 31 December 2018, there was a downward trend in terms of the number of legal proceedings, which was mostly related to the issuance of final decisions, the transactions and the management of real estate assets (e.g. the release of illegally occupied buildings, purchase and sale agreements and other commercial transactions, debt recovery and environmental and administrative procedures).

Furthermore, as at 31 December 2018, CDP Immobiliare was involved in 17 tax disputes and three labour law disputes. In relation to these proceedings, CDP Immobiliare has set aside a prudential reserve of Euro 4.5 million.

#### **CDP Investimenti SGR S.p.A.**

As at 31 December 2018, CDP Investimenti SGR S.p.A. (**CDP Investimenti**) was party to a limited number of civil and administrative disputes related to the management of real estate assets, mostly passive. No significant liabilities have been estimated and accordingly no prudential reserve has been set aside given the expectation that positive outcome of such proceedings is reasonably likely.

Among the above-mentioned disputes, two claims may potentially impact the operations of CDP Investimenti:

- (i) the claim initiated by the Municipality of Tropea before the Regional Administrative Court of Lazio, aimed at voiding the authorisation of the sale by private treaty of the property called "ex Palazzo Giffoni", *inter alia*, as well as any prior or subsequent act, related, consequential and detrimental to the interests of the recurring municipality (including the deed of sale of the asset). Negotiations are underway with the Municipality of Tropea for a favourable court settlement; and
- (ii) the claim initiated by CDP Investimenti before the Lazio Regional Administrative Court for the voiding of the provisions of the Municipality of Rome dated 24 February 2017 and 14 April 2017 to obtain permission to split up the building in Via Guidobaldo Del Monte 24 in Rome, as well as the restoration of the intended use to private offices (the current designation provides for use as public offices exclusively). Negotiations are underway with the Municipality of Rome for a favourable conclusion of the dispute.



## **Fintecna**

As at 31 December 2018, Fintecna was monitoring and managing the legal strategies concerning disputes related to a number of corporate transactions. These monitoring activities included specific targeted assessments of the key threats posed by each dispute.

In particular, Fintecna is party in civil litigations inherited from its legal predecessors in legal proceedings filed by former employees (or their heirs) who have in the past been exposed to asbestos and claim damages due to illnesses allegedly caused by unsafe conditions in the workplace. Currently, with reference to these disputes, the number of pending litigations is unchanged compared to 31 December 2017. Nevertheless, the amount of compensation requested is increasing. The key aim of streamlining and settling the bulk of the claims has been achieved by settling cases that matched certain financial and legal conditions. The results achieved are cost-effective, especially if compared with the potential losses for the company in the event of adverse judicial outcomes. The differences between reported illnesses and case law decided by different courts was taken into account. The cost of these settlements was fully covered by the risk provisions for litigation.

With respect to the number of civil, administrative and tax disputes, the number of new lawsuits served in 2018 was limited and the number of pending cases was slightly reduced. In any case, proceedings are inevitably affected by the timing and complexity of the Italian proceedings system.

In view of the uncertainty of the outcomes of pending litigations, and also due to the different orientations of the Italian courts, claims against the company are covered by the allocation of appropriate funding to the litigation risk provision.

## **FINCANTIERI**

As at 31 December 2018, Fincantieri was directly involved in 5 foreign disputes.

In relation to Italian legal disputes, Fincantieri was mainly involved in: (i) proceedings for the collection of receivables from customers that are insolvent, bankrupt or undergoing other insolvency procedures that could be not resolved commercially; (ii) litigation with suppliers; (iii) employment litigation involving Fincantieri under the "customer co-liability" principle pursuant to article 1676 of the Italian Civil Code and Article 29 of Legislative Decree No. 276/2003; and (iv) other legal disputes, including environmental law disputes with government and municipal bodies, appeals against claims by social security authorities, compensation for direct and indirect damages arising from the production process and civil actions for injury compensation claims.

Furthermore, Fincantieri is currently involved in six criminal cases pursuant to Italian Legislative Decree No. 231 of 2001 before the Gorizia Court.

With reference to tax matters, in 2017 Fincantieri was subject to a tax audit for the fiscal year 2013, which was concluded with the notification of the tax assessment report. In 2018, Fincantieri has been notified of the continuation of the tax assessment. Further defensive activities are underway and a prudential reserve for risks has been set up to cover estimated charges.

In relation to the subsidiary Marine Interiors, with reference to the tax audit conducted by the Trieste Revenue Agency (*Agenzia delle Entrate di Trieste*) in 2017 on the fiscal year 2015, the 2018 notices of assessment were challenged. The same arguments were used by the Pordenone Revenue Agency (*Agenzia delle Entrate di Pordenone*) to adjust the value of the deed of transfer of the branch of business for the purposes of registration tax. The appeal against this investigation was concluded, at first instance, with a favourable judgment for the subsidiary.

With regard to the company Delfi, in September 2018 the Customs Agency (*Agenzia delle Dogane*) launched an audit review for the years 2014-2016, which was later extended to 2013. The audit review focused on the verification of customs operations and VAT. The audit review was concluded with marginal findings.

## SELECTED FINANCIAL INFORMATION RELATING TO CDP

The following tables set out in overview form balance sheet and income statement information relating to CDP. Such information is derived from the audited non-consolidated annual financial statements of CDP at 31 December 2018 and 31 December 2017. Such financial statements together with the reports of the auditors and the certification of the manager responsible for preparing the corporate financial reports, are incorporated by reference into this Base Prospectus. The financial information presented below should be read in conjunction with such financial statements and reports.

On 28 March 2019, the Board of Directors of CDP approved the separate financial statements of CDP for the financial year ended on 31 December 2018<sup>6</sup>.

| Assets - Euros     | Year ended<br>31 December 2018 | Year ended<br>31 December 2017 |
|--------------------|--------------------------------|--------------------------------|
| Loans to banks     | 20,179,064,614                 | 38,599,568,670                 |
| Loans to customers | 303,344,813,275                | 284,163,509,611                |
| Equity investments | 30,316,282,467                 | 30,411,137,574                 |
| Total assets       | 370,015,487,673                | 367,265,268,483                |

| Liabilities and equity - Euros | Year ended<br>31 December 2018 | Year ended<br>31 December 2017 |
|--------------------------------|--------------------------------|--------------------------------|
| Due to banks                   | 30,429,338,747                 | 16,626,997,896                 |
| Due to customers               | 293,196,243,128                | 306,499,360,318                |
| Securities issued              | 18,942,877,795                 | 17,364,495,113                 |
| Equity                         | 24,794,338,321                 | 24,435,072,762                 |

<sup>6</sup> The figures as at 31 December 2017 have been reclassified to the new accounting classes following the first-time adoption (FTA) of IFRS 9 and are in compliance with the provisions of Bank of Italy Circular no. 262/2005, as updated. These figures have not been restated and therefore do not include the effect of the application of the new accounting standards IFRS 9 and IFRS 15, recorded in shareholders' equity as at 1 January 2018.

| Income statement - Euros                                  | Year ended<br>31 December 2018 | Year ended<br>31 December 2017 |
|---|--------------------------------|--------------------------------|
| Net interest income                                       | 3,583,173,110                  | 2,964,685,755                  |
| Net commission income                                     | (1,140,955,547)                | (1,471,383,416)                |
| Gross income  | 3,777,732,005                  | 2,709,412,322                  |
| Financial income<br>(expense), net                        | 3,710,395,828                  | 2,703,696,349                  |
| Operating costs   | (259,766,675)                  | (66,127,068)                   |
| Income (loss) before tax<br>from continuing<br>operations | 3,278,592,317                  | 2,666,195,208                  |
| Income (loss) for the<br>period                           | 2,540,463,436                  | 2,203,445,268                  |

## SELECTED FINANCIAL INFORMATION RELATING TO CDP GROUP

The following tables set out in overview form balance sheet and income statement information relating to CDP Group. Such information is derived from the audited consolidated annual financial statements of CDP Group at 31 December 2018 and 31 December 2017. Such financial statements together with the reports of the auditors and the certification of the manager responsible for preparing the corporate financial reports, are incorporated by reference into this Base Prospectus. The financial information presented below should be read in conjunction with such financial statements and reports.

On 28 March 2019, the Board of Directors of CDP approved the consolidated financial statements of the CDP Group for the financial year ended on 31 December 2018<sup>7</sup>.

| Assets - thousands of Euros | Year ended 31 December 2018 | Year ended 31 December 2017 |
|-----------------------------|-----------------------------|-----------------------------|
| Loans to banks              | 24,825,040                  | 43,137,745                  |
| Loans to customers          | 305,249,808                 | 286,549,273                 |
| Equity investments          | 20,395,661                  | 19,769,766                  |
| Total assets                | 425,082,930                 | 419,533,748                 |

| Liabilities - thousands of Euros | Year ended 31 December 2018 | Year ended 31 December 2017 |
|----------------------------------|-----------------------------|-----------------------------|
| Due to banks                     | 40,905,821                  | 25,934,885                  |
| Due to customers                 | 288,788,232                 | 300,331,654                 |
| Securities issued                | 37,012,634                  | 37,237,527                  |
| Group's Equity                   | 24,056,110                  | 23,061,093                  |

<sup>7</sup> The figures as at 31 December 2017 have been reclassified to the new accounting classes following the first-time adoption (FTA) of IFRS 9 and are in compliance with the provisions of Bank of Italy Circular no. 262/2005, as updated. These figures have not been restated and therefore do not include the effect of the application of the new accounting standards IFRS 9 and IFRS 15, recorded in shareholders' equity as at 1 January 2018.

| thousands of Euros  | Year ended<br>31 December 2018 | Year ended<br>31 December 2017 |
|---|--------------------------------|--------------------------------|
| Net interest income   | 3,485,018                      | 2,760,691                      |
| Net commission income   | (1,126,224)                    | (1,468,441)                    |
| Gross income  | 2,257,927                      | 829,504                        |
| Financial income (expense),<br>net  | 2,143,849                      | 799,536                        |
| Net income from financial and<br>insurance operations                                 | 2,216,370                      | 1,664,315                      |
| Operating costs   | 2,449,476                      | 2,348,007                      |
| Income (loss) before tax from<br>continuing operations                                | 5,792,867                      | 5,658,432                      |
| Income (loss) after tax on<br>continuing operations                                   | 4,333,455                      | 4,461,658                      |
| Net income (loss) for the year  | 4,333,455                      | 4,461,658                      |
| Net income (loss) for the year<br>pertaining to shareholders of<br>the Parent Company | 2,890,851                      | 2,943,314                      |

## TAXATION

### Italian taxation

*The following is a general overview of current Italian law and practice relating to certain Italian tax considerations concerning the purchase, ownership and disposition of the Notes. It does not purport to be a complete analysis of all tax considerations that may be relevant to a decision to purchase, own or dispose of the Notes and does not purport to deal with the tax consequences applicable to all categories of prospective beneficial owners of Notes, some of which may be subject to special rules. The following overview does not discuss in details the treatment of Notes that are held in connection with a permanent establishment or fixed base through which a non-Italian resident beneficial owner carries on business or performs professional services in Italy.*

*This overview is based upon tax laws in force in Italy in effect as at the date of this Base Prospectus, which may be subject to any changes in law occurring after such date potentially with retroactive effect. Prospective purchasers of Notes should consult their tax advisers as to the consequences under Italian tax law, under the tax laws of the country in which they are resident for tax purposes and of any other potentially relevant jurisdiction of acquiring, holding and disposing of Notes and receiving payments of interest, principal and/or other amounts under the Notes, including in particular the effect of any state, regional or local tax laws. This paragraph does not intend and cannot be construed as a tax advice to prospective purchaser of the Notes.*

### Italian Tax treatment of the Notes

Italian Legislative Decree no. 239 of 1 April, 1996 ("**Decree No. 239**") regulates the tax treatment of interest, premiums and other income (including the difference between the redemption amount and the issue price) (hereinafter collectively referred to as "**Interest**") deriving from Notes falling within the category of bonds (*obbligazioni*) and securities similar to bonds (pursuant to Article 44 of Presidential Decree No. 917 of 22 December 1986, as amended and supplemented ("**Decree No. 917**") issued, *inter alia*, by CDP pursuant to the provisions of Article 5, paragraph 25, of Law Decree No. 269 of 30 September 2003, converted with amendments into Law No. 326 of 24 November 2003, as supplemented from time to time.

For these purposes, securities similar to bonds ("*titoli similari alle obbligazioni*") are securities that incorporate an unconditional obligation of the issuer to pay at maturity an amount not lower than their nominal value, with or without the payment of periodic interest, and do not give any right to directly or indirectly participate in the management of the issuer or to the business in connection to which the securities were issued, nor to control the same.

### Italian Resident Noteholders

Pursuant to Decree No. 239, payments of Interest relating to Notes is subject to the *imposta sostitutiva*, levied at the rate of 26 per cent. if the Noteholder is:

- (i) an individual resident in the Republic of Italy for tax purposes, holding the Notes otherwise than in connection with entrepreneurial activities; or

- (ii) Italian resident partnership (other than *società in nome collettivo*, *società in accomandita semplice* or similar partnerships), or a de facto partnership not carrying out commercial activities and professional associations; or
- (iii) Italian resident public and private entities other than companies, trusts not carrying out mainly or exclusively commercial activities, the Italian State and public and territorial entities; or
- (iv) Italian resident entities exempt from Italian corporate income tax.

All the above categories are usually referred as "net recipients" unless the Noteholders referred to under (i), (ii) and (iii) above have entrusted the management of their financial assets, including the Notes, to an authorised intermediary and have opted for the so called "*regime del risparmio gestito*" (the *Risparmio Gestito* regime) according to Article 7 of Italian Legislative Decree No. 461 of 21 November 1997 as amended ("**Decree No. 461**").

In the event that the Italian resident Noteholders mentioned above hold the Notes in connection with an entrepreneurial activity (*attività d'impresa*), the *imposta sostitutiva* applies as a provisional tax. Interest will be included in the relevant beneficial owner's Italian income tax return and will be subject to Italian ordinary income taxation and the *imposta sostitutiva* may be recovered as a deduction from Italian income tax due.

Interest accrued on the Notes must be included in the relevant Noteholder's annual corporate taxable income (and in certain circumstances, depending on the "status" of the Noteholders, also in the net value of production for purposes of regional tax on productive activities ("**IRAP**")) if the Noteholder is an Italian resident corporation or permanent establishment in Italy of foreign corporation to which the Notes are effectively connected, subject to tax in Italy in accordance with ordinary tax rules.

Subject to certain limitations and requirements (including a minimum holding period), Italian resident individuals not acting in connection with an entrepreneurial activity or social security entities pursuant to Legislative Decree No. 509 of 30 June 1994 and Legislative Decree No. 103 of 10 February 1996 may be exempt from any income taxation, including the *imposta sostitutiva*, on Interest if the Notes are included in a long-term savings account (*piano di risparmio a lungo termine*) that meets the requirements set forth in Article 1, paragraph 100-114 of Law No. 232 of 11 December 2016 ("**Law No. 232**") and in Article 1, paragraph 210-215 of Law No. 145 of 30 December 2018 (the "**Law No. 145**").

Pursuant to Decree No. 239, the *imposta sostitutiva* is levied by banks, *società di intermediazione mobiliare* ("**SIM**"), fiduciary companies, *società di gestione del risparmio* ("**SGR**") stockbrokers and other entities identified by the Ministry of Finance (each, an "**Intermediary**"). An Intermediary must (a) be resident in Italy, or be a permanent establishment in Italy of a non-Italian resident financial intermediary, and (b) participate, in any way, in the collection of Interest or in the transfer of the Notes.

Where the Notes are not deposited with an Intermediary, the *imposta sostitutiva* is applied and withheld by the relevant Italian financial intermediary (or permanent



establishment in Italy of a non-Italian resident financial intermediary) paying the Interest to a Noteholder, or, in its absence, by the Issuer.

Payments of Interest in respect of Notes will not be subject to the *imposta sostitutiva* if made to beneficial owners who are:

- (i) Italian resident corporations or permanent establishments in Italy of non-resident corporations to which the Notes are effectively connected;
- (ii) Italian resident partnerships carrying out commercial activities ("*società in nome collettivo*" or "*società in accomandita semplice*")
- (iii) Italian resident investors holding Notes otherwise than in connection with entrepreneurial activity who have entrusted the management of their financial assets, including the Notes to an authorised financial intermediary and have opted for the *Risparmio Gestito* regime; Italian resident investors holding Notes otherwise than in connection with entrepreneurial activity who have opted for the *Risparmio Gestito* regime are subject to an annual substitutive tax of 26 per cent. (the "**Asset Management Tax**") on the increase in value of the managed assets accrued at the end of each tax year (which increase would include interest and other proceeds accrued on the Notes). The Asset Management Tax is applied by authorised Intermediaries;
- (iv) Italian resident pension funds referred to in Legislative Decree No. 252 of 5 December 2005 ("**Decree No. 252**"). Italian resident pension funds subject to the regime provided by Articles 17, of Decree No. 252 are subject to an annual substitutive tax of 20 per cent. (the "**Pension Fund Tax**") on the increase in value of the managed assets accrued at the end of each tax year (which would include Interest accrued on the Notes, if any). Subject to certain conditions, Interest in respect of the Notes may be excluded from the taxable base of the Pension Fund Tax pursuant to Article 1, paragraph 92, of Law No. 232 if the Notes are included in a long-term savings account (*piano individuale di risparmio a lungo termine*) pursuant to Article 1, paragraph 100 – 114, of Law No. 232 and in Article 1, paragraph 210 - 215 of Law No. 145;
- (v) Italian open ended or closed ended investment funds, investment companies with fixed capital (SICAFs) or investment companies with variable capital (SICAVs) established in Italy (together, the "**Fund**") when either (i) the Fund or (ii) its manager is subject to the supervision of a regulatory authority and the relevant Notes are held by an authorised intermediary. In such case, Interest accrued during the holding period on the Notes will not be subject to *imposta sostitutiva*, but must be included in the management results of the Fund. The Fund will not be subject to taxation on such results, but a withholding tax of 26 per cent. may apply on income of the Fund derived by unitholders or shareholders through distribution and/or redemption or disposal of the units and shares;
- (vi) Italian resident real estate investment funds (complying with the definition as amended pursuant to Law Decree No. 78 of 31 May 2010, converted into Law No. 122 of 30 July 2010) established after 26 September 2001 pursuant to Article 37 of Legislative Decree No. 58 and Article 14-bis of Law No. 86 of 25 January 1994, or in any case subject to the tax treatment provided for by

Law Decree No. 351 of 25 September 2001, converted into law with amendments by Law No. 410 of 23 November 2001 ("**Decree No. 351**") and Italian resident SICAFs to which the provisions of Article 9 of Legislative Decree No. 44 of 4 March 2014 apply, hereinafter the ("**Real Estate Investment Funds**"); and

### **Non-Italian Resident Noteholders**

Where the Noteholder is a non-Italian resident (with no permanent establishment in the Republic of Italy to which the Notes are effectively connected), provided that the non-Italian resident beneficial owner is:

- (a) resident, for tax purposes, in a State or territory included in the list of States or territories allowing an adequate exchange of information with the Italian tax authorities and listed in the Decree of the Minister of Finance dated 4 September 1996, as amended and supplemented by Italian Ministerial Decree dated 23 March 2017 and possibly further amended by future decree issued pursuant to Article 11(4)(c) of Decree 239 (the "**White List**"); or
- (b) an international body or entity set up in accordance with international agreements which have entered into force in Italy; or
- (c) an "institutional investor", whether or not subject to tax, which is established in a country included in the White List; or
- (d) a Central Bank or an entity which manages, *inter alia*, the official reserves of a foreign State;

all the requirements and procedures set forth in Decree No. 239 and in the relevant application rules, as subsequently amended and supplemented, in order to benefit from the exemption from *imposta sostitutiva* are timely met and complied with.

Such categories are usually referred as "gross recipients". To ensure payment of Interest in respect of the Notes without the application of *imposta sostitutiva*, gross recipients must (i) be the beneficial owners of payments of Interest on the Notes; (ii) timely deposit the Notes together with the coupons relating to such Notes, if any, directly or indirectly with an Italian authorised financial intermediary (or permanent establishment in Italy of a foreign intermediary); and (iii) in the event of non-Italian resident beneficial owners timely file with the relevant depository (which may be a non-Italian resident entity participating in a centralised securities management system connected via telematic link with the Italian Ministry of Economy and Finance) a self-declaration (*autocertificazione*) stating their residence, for tax purposes, in a State listed in the White List. Such self-declaration – which must comply with the requirements set forth by Ministerial Decree of 12 December 2001 (as amended and supplemented) – is valid until withdrawn or revoked and may not be filed in the event that a certificate, declaration or other similar document with an equivalent purpose has previously been filed with the same depository. The self-declaration (*autocertificazione*) is not required for non-Italian resident investors that are international entities and organisations established in accordance with international agreements ratified in Italy and Central Banks or entities which manage, *inter alia*, the official reserves of a foreign state.

Failure of a non-resident holder of the Notes to comply in due time with the procedures set forth in Decree No. 239 and in the relevant implementation rules will result in the application of *imposta sostitutiva* on Interests payments to a non-resident holder of the Notes.

Non-resident holders of the Notes who are subject to substitute tax might, nevertheless, be eligible for a total or partial relief under an applicable tax treaty between the Republic of Italy and the country of residence of the relevant holder of the Notes.

### **Atypical Securities**

Interest payments relating to Notes that are not deemed to be bonds (*obbligazioni*), debentures similar to bonds (*titoli similari alle obbligazioni*), shares or securities similar to shares pursuant to Article 44 of Decree No. 917 may be subject to a withholding tax, levied at the rate of 26 per cent. under Law Decree No. 512 of 30 September 1983. For this purpose, debentures similar to bonds are securities that incorporate an unconditional obligation of the issuer to pay at maturity an amount not lower than their nominal value, with or without the payment of periodic interest, and do not give any right to directly or indirectly participate in the management of the issuer or to the business in connection to which the securities were issued, nor to control the same.

Subject to certain limitations and requirements (including a minimum holding period), Italian resident individuals not acting in connection with an entrepreneurial activity or social security entities pursuant to Legislative Decree No. 509 of 30 June 1994 and Legislative Decree No. 103 of 10 February 1996 may be exempt from any income taxation, including the withholding tax on Interest relating to the Notes not falling within the category of bonds (*obbligazioni*) or debentures similar to bonds (*titoli similari alle obbligazioni*), shares or securities similar to shares pursuant to Article 44 of Decree No. 917, if such Notes are included in a long-term individual savings account (*piano individuale di risparmio a lungo termine*) that meets the requirements set forth in Article 1, paragraph 100 - 114 of Law No. 232 and in Article 1, paragraph 210 – 215 of Law No. 145.

Where the Noteholder is (a) an Italian individual engaged in an entrepreneurial activity to which the Notes are connected, (b) an Italian company or a similar Italian commercial entity, (c) a permanent establishment in Italy of a foreign entity, (d) an Italian commercial partnership or (e) an Italian commercial private or public institution, such withholding tax is a provisional withholding tax. In all other cases the withholding tax is a final withholding tax. For a non-Italian resident Noteholders, the withholding tax rate may be reduced by any applicable tax treaty.

### **Taxation of Capital Gains**

Any capital gain realised upon the sale for consideration, transfer or redemption of the Notes would be treated as part of the taxable business income (and, in certain cases depending on the status of Noteholder, may also be included in the taxable net value of production for IRAP purposes), subject to tax in Italy according to the relevant tax provisions, if derived by Noteholders who are:

- (a) Italian resident corporations;

- (b) permanent establishments in Italy of foreign corporations to which the Notes are effectively connected; or
- (c) Italian resident individuals carrying out a commercial activity, as to any capital gains realised within the scope of the commercial activity.

Where an Italian resident Noteholder is an (i) individual holding the Notes otherwise than in connection with entrepreneurial activity, (ii) a non-commercial partnership, (iii) a non-commercial private or public institution, any capital gain realised by such Noteholder from the sale for consideration or redemption of the Notes would be subject to a substitute tax at the current rate of 26 per cent..

Under the tax return regime (the "**Regime della Dichiarazione**"), which is the standard regime for taxation of capital gains realised by Italian Noteholders under (i) to (iii) above, substitute tax on capital gains will be chargeable, on a cumulative basis, on all capital gains, net of any relevant incurred capital loss, realised by Italian resident individual Noteholders holding Notes otherwise than in connection with entrepreneurial activity pursuant to all disposals of Notes carried out during any given tax year. Italian resident individuals holding Notes not in connection with entrepreneurial activity must report total capital gains realised in any tax year, net of any relevant incurred capital loss, in the annual tax return to be filed with the Italian tax authorities for such year and pay substitute tax on such gains together with any balance income tax due for such year. Capital losses in excess of capital gains may be carried forward against capital gains of the same kind realised in any of the four succeeding tax years.

As an alternative to the tax return regime depicted above, Italian Noteholders under (i) to (iii) above, may elect to pay 26 per cent. substitute tax separately on capital gains realised on each sale, transfer or redemption of the Notes (the "**Risparmio Amministrato**" regime). Such separate taxation of capital gains is allowed subject to (i) the Notes being deposited with Italian banks, SIMs or certain authorised financial intermediaries; and (ii) an election for the *Risparmio Amministrato* regime being timely made in writing by the relevant Noteholder. The financial intermediary is responsible for accounting for substitute tax in respect of capital gains realised on each sale, transfer or redemption of the Notes (as well as in respect of capital gains realised at revocation of its mandate), net of any relevant incurred capital loss, and is required to pay the relevant amount to the Italian tax authorities on behalf of the taxpayer, deducting a corresponding amount from proceeds to be credited to the Noteholder. Under the *Risparmio Amministrato* regime, the Noteholder is not required to declare capital gains in its annual tax return and remains anonymous. Capital losses in excess of capital gains may be carried forward against capital gains of the same kind realised in any of the four succeeding tax years

Any capital gains on Notes held by Noteholders under (i) to (iii) above, who have elected for the *Risparmio Gestito* regime will be included in the computation of the annual increase in value of the managed assets accrued, even if not realised, at year end, subject to the Asset Management Tax to be applied on behalf of the taxpayer by the managing authorised intermediary. Under the *Risparmio Gestito* regime, any depreciation of the managed assets, accrued at year end, may be carried forward against any increase in value of the managed assets accrued in any of the four subsequent years. Under the *Risparmio Gestito* regime, the Noteholder is not

required to report capital gains realised in its annual tax return and remains anonymous.

Subject to certain limitations and requirements (including a minimum holding period), capital gains in respect of Notes realised upon sale, transfer or redemption by Italian resident individuals holding the Notes not in connection with an entrepreneurial activity or social security entities pursuant to Legislative Decree No. 509 of 30 June 1994 and Legislative Decree No. 103 of 10 February 1996 may be exempt from taxation, including the 26 per cent. *imposta sostitutiva*, if the Notes are included in a long-term individual savings account (*piano individuale di risparmio a lungo termine*) pursuant Article 1, paragraph 100 – 114, of Law No. 232 and in Article 1, paragraph 210 - 215 of Law No. 145.

Any capital gains on Notes held by Noteholders who are Italian resident pension funds subject to the regime provided by Article 17 of Decree No. 252, will be included in the computation of the taxable basis of Pension Fund Tax. Subject to certain conditions, capital gains realised in respect to the Notes may be excluded from the taxable base of the Pension Fund Tax pursuant to Article 1, paragraph 92, of Law No. 232 if the Notes are included in a long-term savings account (*piano individuale di risparmio a lungo termine*) pursuant to Article 1, paragraph 100 – 114, of Law No. 232 and in Article 1, paragraph 210 - 215 of Law No. 145.

Any capital gains realised by a Noteholder which is a Fund will not be subject to *imposta sostitutiva*, but will be included in the result of the relevant portfolio. The Fund will not be subject to taxation on such result but a withholding tax of 26 per cent. may apply on income of the Fund derived by unitholders or shareholders through distribution and/or redemption or disposal of the units and shares.

Capital gains on Notes held by Italian Real Estate Investment Funds are not taxable at the level of same Real Estate Investment Funds.

The 26 per cent. substitute tax on capital gains may, in certain circumstances, be payable on capital gains realised upon sale for consideration or redemption of the Notes by non-Italian resident persons or entities without a permanent establishment in Italy to which the Notes are effectively connected, if the Notes are held in Italy.

Capital gains realised by non-Italian residents without a permanent establishment in Italy to which the Notes are effectively connected through the sale for consideration or redemption of Notes are exempt from taxation in Italy to the extent that the Notes are traded on a regulated market in Italy or abroad and in certain cases subject to prompt filing of required documentation (in particular, a self-declaration of non-residence in Italy for tax purposes) with Italian qualified intermediaries (or permanent establishments in Italy of foreign intermediaries) with whom the Notes are deposited, even if the Notes are held in Italy and regardless of the provisions set forth by any applicable double tax treaty.

In case the Notes are not traded on a regulated market in Italy or abroad:

- (a) pursuant to the provisions of Decree No. 461, non-Italian resident beneficial owners of the Notes with no permanent establishment in Italy to which the Notes are effectively connected are exempt from taxation in the Republic of Italy on any capital gains realised upon sale for consideration or redemption of

the Notes if (a) they are resident, for tax purposes, in a state or territory included in the White List and (b) all the requirements and procedures set forth in Decree No. 239 and in the relevant implementation rules, as subsequently amended, in order to benefit from the exemption from *imposta sostitutiva* are met or complied with in due time. In this case, if non-Italian residents without a permanent establishment in Italy to which the Notes are effectively connected elect for the *Risparmio Amministrato* regime or the *Risparmio Gestito* regime, exemption from Italian taxation on capital gains will apply upon condition that they file in due time with the authorised financial intermediary an appropriate self-declaration (*autocertificazione*) stating that they meet the requirement reported above.

- (b) in any event, non-Italian resident persons or entities without a permanent establishment in Italy to which the Notes are effectively connected that may benefit from a double taxation treaty with the Republic of Italy, providing that capital gains realised upon sale or redemption of Notes are to be taxed only in the country of tax residence of the recipient, will not be subject to taxation in the Republic of Italy on any capital gains realised upon sale for consideration or redemption of Notes.

In this case, exemption from Italian taxation on capital gains will apply upon condition that they file in due time with the authorised financial intermediary appropriate documentation attesting that the requirements for the application of the relevant double taxation treaty are met.

The *Risparmio Amministrato* regime is the ordinary regime automatically applicable to non-resident persons and entities in relation to Notes deposited for safekeeping or administration at Italian banks, SIMs and other eligible entities, but non-resident Noteholders retain the right to waive this regime. Such waiver may also be exercised by non-resident intermediaries in respect of safekeeping, administration and deposit accounts held in their names in which third parties' financial assets are held.

### **Inheritance and gift tax**

Pursuant to Law Decree No. 262 of 3 October, 2006, converted into Law No. 286 of 24 November, 2006 as amended by Law No. 296 of 27 December 2006, the transfers of any valuable asset (such as the Notes) by reason of gift, donation or succession proceedings is subject to Italian gift and inheritance tax as follows:

- (a) transfers in favour of spouses and direct descendants or direct ancestors are subject to an inheritance and gift tax applied at a rate of 4 per cent. on the value of the inheritance or the gift exceeding Euro 1,000,000.00 (per beneficiary);
- (b) transfers in favour of relatives to the fourth degree or relatives-in-law to the third degree are subject to an inheritance and gift tax at a rate of 6 per cent. on the entire value of the inheritance or the gift;
- (c) transfers in favour of brothers/sisters are subject to the 6 per cent. inheritance and gift tax on the value of the inheritance or the gift exceeding Euro 100,000.00 (per beneficiary); and

- (d) any other transfer is subject to an inheritance and gift tax applied at a rate of 8 per cent. on the entire value of the inheritance or the gift.
- (e) If the transfer is made in favour of persons with severe disabilities, the tax applies on the value exceeding Euro 1,500,000.

Moreover, an anti-avoidance rule is provided for by Law No. 383/2001 for any gift of assets (such as the Notes) which, if sold for consideration, would give rise to capital gains to the "*imposta sostitutiva*" provided for by Italian Decree No. 461/1997. In particular, if the donee sells the Notes for consideration within 5 years from the receipt thereof as a gift, the donee is required to pay the relevant "*imposta sostitutiva*" on capital gains as if the gift was not made.

### **Transfer tax**

Contracts relating to the transfer of securities are subject to the registration tax as follows: (i) public deeds and notarized deeds (*atti pubblici e scritture private autenticate*) are subject to fixed registration tax at rate of €200; (ii) private deeds (*scritture private non autenticate*) are subject to registration tax at rate of €200 only in case of use or voluntary registration or occurrence of the so-called *enunciazione*.

### **Stamp duty on financial instruments**

Pursuant to Article 13 par. 2/ter of the tariff Part I attached to Presidential Decree No. 642 of 26 October 1972, a proportional stamp duty applies on an annual basis to any periodic reporting communications which may be sent by a financial intermediary to their clients in respect of any Notes which may be deposited with such financial intermediary in Italy. The stamp duty applies at a rate of 0.2 per cent. and it cannot exceed €14,000 for taxpayers which are not individuals. This stamp duty is determined on the basis of the market value or – if no market value figure is available – the nominal value or redemption amount of the Notes held.

The statement is considered to be sent at least once a year, even for instruments for which is not mandatory nor the deposit nor the release or the drafting of the statement. In case of reporting periods of less than 12 months, the stamp duty is payable pro-rata.

Based on the wording of the law and the implementing decree issued by the Italian Ministry of Economy on 24 May 2012, the stamp duty applies to any investor who is a client (as defined in the regulations issued by the Bank of Italy on 20 June 2012) of an entity that exercises in any form a banking, financial or insurance activity within the Italian territory.

### **Wealth tax on financial assets deposited abroad**

According to Article 19 of Law Decree No. 201 of 6 December 2011, Italian resident individuals holding financial assets – including the Notes – outside of the Italian territory are required to pay in its own annual tax declaration a wealth tax at the rate of 0.2 per cent. This tax is calculated on the market value at the end of the relevant year (or at the end of the holding period) or – if no market value figure is available – on the nominal value or redemption value, or in the case the nominal or redemption values cannot be determined, on the purchase value of any financial asset (including

the Notes) held outside of the Italian territory. A tax credit is granted for any foreign property tax levied abroad on such financial assets. The Italian tax authority clarified (Circular No. 28/E of 2 July 2012) that financial assets held abroad are excluded from the scope of the wealth tax if they are administered by Italian financial intermediaries and the items of income derived from the Notes have been subject to the stamp duty on financial instruments by the same intermediaries.

### **Tax monitoring obligations**

Pursuant to Law Decree No. 167 of 28 June 1990, converted by Law No. 227 of 4 August 1990, as amended from time to time, individuals, non-profit entities and certain partnerships (*società semplici* or similar partnerships in accordance with Article 5 of Decree No. 917) resident in Italy who hold investments abroad or have financial activities abroad or are the beneficial owners, under the Italian money-laundering law, provided by Italian Legislative Decree No. 231 of 21 November 2007, of investments abroad or foreign financial assets must, in certain circumstances, disclose the aforesaid to the Italian tax authorities in their income tax return (or, in case the income tax return is not due, in a proper form that must be filed within the same time as prescribed for the income tax return).

Furthermore, the above reporting requirement is not required to comply with respect to: (i) Notes deposited for management with qualified Italian financial intermediaries; (ii) contracts entered into through Italian financial intermediaries intervention, upon condition that the items of income derived from the Notes have been subject to tax by the same intermediaries; or (iii) if the foreign investments are only composed by deposits and/or bank accounts and their aggregate value does not exceed a €15,000 threshold throughout the year.

### **Luxembourg Taxation**

*The following information is of a general nature and is based on the laws currently in force in Luxembourg. It specifically contains information on taxes on the income from the Notes withheld at source and provides an indication as to whether the Issuer assumes responsibility for the withholding of taxes at the source. It does not purport to be, nor should it be construed as, a complete analysis of all tax considerations relating to the Notes, whether in Luxembourg or elsewhere, or legal or tax advice. Prospective purchasers of the Notes should consult their own tax advisers as to which countries' tax laws could be relevant to acquiring, holding and disposing of the Notes payments of interest, principal and/or other amounts under the Notes and the consequences of such actions under the tax laws of Luxembourg. This information is based upon the law as in effect on the date of this Base Prospectus. The information contained within this section is limited to Luxembourg withholding taxation issues, and prospective investors should not apply any information set out below to other areas, including (but not limited to) the legality of transactions involving the Notes.*

*Please be aware that the residence concept used under the respective headings below applies for Luxembourg income tax assessment purposes only. Any reference in the present section to a withholding tax or a tax of a similar nature refers to Luxembourg tax law and/or concepts only.*



## **Withholding tax**

### **(i) Non-resident holders of Notes**

Under Luxembourg general tax laws currently in force, there is no withholding tax on payments of principal, premium or interest made to non-resident holders of Notes, nor on accrued but unpaid interest in respect of the Notes, nor is any Luxembourg withholding tax payable upon redemption or repurchase of the Notes held by non-resident holders of Notes.

### **(ii) Resident holders of Notes**

Under Luxembourg general tax laws currently in force and subject to the law of 23 December 2005, as amended (the "**Relibi Law**"), there is no withholding tax on payments of principal, premium or interest made to Luxembourg resident holders of Notes, nor on accrued but unpaid interest in respect of Notes, nor is any Luxembourg withholding tax payable upon redemption or repurchase of Notes held by Luxembourg resident holders of Notes.

Under the Relibi Law, payments of interest or similar income made or ascribed by a paying agent established in Luxembourg to an individual beneficial owner who is a resident of Luxembourg will be subject to a withholding tax of currently 20 per cent.. Such withholding tax will be in full discharge of income tax if the beneficial owner is an individual acting in the course of the management of his/her private wealth. Responsibility for the withholding of the tax will be assumed by the Luxembourg paying agent. Payments of interest under the Notes coming within the scope of the Relibi Law will be subject to a withholding tax at a rate of currently 20 per cent..

## **Other Taxation issues**

### **The proposed financial transactions tax (FTT)**

On 14 February 2013, the European Commission published a proposal for a Directive for a common FTT in Belgium, Germany, Estonia, Greece, Spain, France, Italy, Austria, Portugal, Slovenia and Slovakia (the **participating Member States**).

The proposed FTT has a very broad scope and could, if introduced in its current form, apply to certain dealings in Notes (including secondary market transactions) in certain circumstances. The issuance and subscription of Notes should, however, be exempt.

Under current proposals the FTT could apply in certain circumstances to persons both within and outside of the participating Member States. Generally, it would apply to certain dealings in Notes where at least one party is a financial institution, and at least one party is established in a participating Member State. A financial institution may be, or be deemed to be, "established" in a participating Member State in a broad range of circumstances, including (a) by transacting with a person established in a participating Member State or (b) where the financial instrument which is subject to the dealings is issued in a participating Member State.

Joint statements issued on 8 December 2015 by participating Member States, except Estonia, indicate an intention to implement the FTT by the end of June 2016.

On 16 March 2016, Estonia completed the formalities required to leave the enhanced co-operation on FTT. On 7 December 2017, the Council of the European Union announced that further work on FTT will be required before a final agreement on this dossier can be reached among the Member States participating in the enhanced co-operation.

Prospective holders of the Notes are advised to seek their own professional advice in relation to the FTT.

### **United States Foreign Account Tax Compliance Act**

Pursuant to certain provisions of the U.S. Internal Revenue Code of 1986, commonly known as FATCA, a "foreign financial institution" may be required to withhold on certain payments it makes ("foreign passthru payments") to persons that fail to meet certain certification, reporting, or related requirements. The Issuer does not expect to be treated as a foreign financial institution for these purposes. A number of jurisdictions (including Italy) have entered into, or have agreed in substance to, intergovernmental agreements with the United States to implement FATCA ("**IGAs**"), which modify the way in which FATCA applies in their jurisdictions. Under the provisions of IGAs as currently in effect, a foreign financial institution in an IGA jurisdiction would generally not be required to withhold under FATCA or an IGA from payments that it makes. Certain aspects of the application of the FATCA provisions and IGAs to instruments such as the Notes, including whether withholding would ever be required pursuant to FATCA or an IGA with respect to payments on instruments such as the Notes, are uncertain and may be subject to change. Even if withholding would be required pursuant to FATCA or an IGA with respect to payments on instruments such as the Notes, such withholding would not apply prior to the date that is two years after the date on which final regulations defining "foreign passthru payments" are published in the U.S. Federal Register and Notes characterised as debt (or which are not otherwise characterised as equity and have a fixed term) for U.S. federal tax purposes that are issued on or prior to the date that is six months after the date on which final regulations defining foreign passthru payments are filed with the U.S. Federal Register generally would be "grandfathered" for purposes of FATCA withholding unless materially modified after such date. However, if additional notes (as described under "Terms and Conditions of the Notes—Further Issues") that are not distinguishable from previously issued Notes are issued after the expiration of the grandfathering period and are subject to withholding under FATCA, then withholding agents may treat all Notes, including the Notes offered prior to the expiration of the grandfathering period, as subject to withholding under FATCA. Holders should consult their own tax advisors regarding how these rules may apply to their investment in the Notes. In the event any withholding would be required pursuant to FATCA or an IGA with respect to payments on the Notes, no person will be required to pay additional amounts as a result of the withholding.

**FATCA** is particularly complex and its application is uncertain at this time. The above description is based in part on regulations, official guidance and model IGAs, all of which are subject to change or may be implemented in a materially different form. Prospective investors should consult their tax advisors on how these rules may apply to payments they may receive in connection with the Notes.

## SUBSCRIPTION AND SALE

### Dealer Agreement

Notes may be sold from time to time by the Issuer to any one or more of Banca IMI S.p.A., Barclays Bank Ireland PLC, Barclays Bank PLC, BNP Paribas, BofA Securities Europe SA, Citigroup Global Markets Europe AG, Citigroup Global Markets Limited, Commerzbank Aktiengesellschaft, Crédit Agricole Corporate and Investment Bank, Credit Suisse Securities (Europe) Limited, Deutsche Bank AG, London Branch, HSBC France, J.P. Morgan Securities plc, Mediobanca – Banca di Credito Finanziario S.p.A., Merrill Lynch International, Morgan Stanley & Co. International plc, MPS Capital Services Banca per le Imprese S.p.A., Nomura International plc, Société Générale, UBS Europe SE, and UniCredit Bank AG (the "**Dealers**"). The arrangements under which Notes may from time to time be agreed to be sold by the Issuer to, and purchased by, Dealers are set out in a dealer agreement dated 20 May 2015 as amended by an amendment agreement dated 12 May 2017, by a second amendment agreement dated 9 May 2018 and by a third amendment agreement dated 10 May 2019 (as further amended and supplemented from time to time, the "**Dealer Agreement**") and made between the Issuer, the Representative of the Noteholders and the Dealers, as amended and supplemented from time to time. If in the case of any Tranche of Notes the method of distribution is an agreement between the Issuer and a single Dealer for that Tranche to be issued by the Issuer and subscribed by that Dealer, the method of distribution will be described in the relevant Final Terms as "Non-Syndicated" and the name of that Dealer and any other interest of that Dealer which is material to the issue of that Tranche beyond the fact of the appointment of that Dealer will be set out in the relevant Final Terms. If in the case of any Tranche of Notes the method of distribution is an agreement between the Issuer and more than one Dealer for that Tranche to be issued by the Issuer and subscribed by those Dealers, the method of distribution will be described in the relevant Final Terms as "Syndicated", the obligations of those Dealers to subscribe the relevant Notes will be joint and several and the names and addresses of those Dealers and any other interests of any of those Dealers which is material to the issue of that Tranche beyond the fact of the appointment of those Dealers (including whether any of those Dealers has also been appointed to act as Stabilising Manager in relation to that Tranche) will be set out in the relevant Final Terms.

Any such agreement will, *inter alia*, make provision for the form and terms and conditions of the relevant Notes, the price at which such Notes will be subscribed by the Dealer(s) and the commissions or other agreed deductibles (if any) payable or allowable by the Issuer in respect of such subscription. The Dealer Agreement makes provision for the resignation or termination of appointment of existing Dealers and for the appointment of additional or other Dealers either generally in respect of the Programme or in relation to a particular Tranche of Notes.

### Subscription Agreements

Any agreement between CDP, the Representative of the Noteholders and any one or more of the Dealers and/or any additional or other dealers, from time to time for the sale and purchase of Notes (a "**Subscription Agreement**" and each Dealer party thereto, a "**Relevant Dealer**") will *inter alia* make provision for the price at which the

relevant Notes will be purchased by the Relevant Dealers and the commissions or other agreed deductibles (if any) payable or allowable by CDP in respect of such purchase.

Each Subscription Agreement will also provide for the appointment of the Representative of the Noteholders by the Relevant Dealer(s) as initial holder(s) of the Notes then being issued.

The Dealers are entitled in certain circumstances to be released and discharged from their obligations under the Subscription Agreement prior to the closing of the issue of the Notes.

## **Selling restrictions**

### ***General selling restrictions***

Each Dealer has agreed and each further Dealer appointed under the Programme will be required to agree that it will comply to the best of its knowledge and belief with all relevant laws, regulations and directives in each jurisdiction in which it purchases, offers, sells or delivers Notes or has in its possession or distributes the Base Prospectus, any other offering material or any Final Terms and neither CDP nor any other Dealer shall have responsibility therefor. Persons into whose hands the Base Prospectus or any Final Terms comes are required by CDP and the Dealers to comply with all applicable laws and regulations in each country or jurisdiction in or from which they purchase, offer, sell or deliver Notes or possess, distribute or publish this Base Prospectus or any Final Terms or any related offering material, in all cases at their own expense.

The Dealer Agreement provides that the Dealers shall not be bound by any of the restrictions relating to any specific jurisdiction (set out above) to the extent that such restrictions shall, as a result of change(s) or change(s) in official interpretation, after the date hereof, of applicable laws and regulations, no longer be applicable but without prejudice to the obligations of the Dealers described in this paragraph.

Selling restrictions may be supplemented or modified with the agreement of CDP. Any such supplement or modification will be set out in a supplement to this Base Prospectus or in the relevant Final Terms (in case of a supplement or modification only to a particular Tranche of Notes).

### ***Republic of Italy***

The offering of the Notes has not been registered pursuant to Italian securities legislation and, accordingly, no Notes may be offered, sold or delivered, nor may copies of the Base Prospectus or of any other document relating to the Notes be distributed in the Republic of Italy, except:

- (i) to qualified investors (*investitori qualificati*), as defined pursuant to Article 100 of Legislative Decree No. 58 of 24 February 1998, as amended (the **Financial Services Act**) and Article 34-ter, first paragraph, letter b) of CONSOB Regulation No. 11971 of 14 May 1999, as amended from time to time (**Regulation No. 11971**); or

- (ii) in circumstances which are exempted from the rules on public offerings pursuant to Article 100 of the Financial Services Act and Article 34-ter of Regulation No. 11971.

Any offer, sale or delivery of the Notes or distribution of copies of this Base Prospectus or any other document relating to the Notes in the Republic of Italy under (i) or (ii) above must:

- (a) be made by an investment firm, bank or financial intermediary permitted to conduct such activities in the Republic of Italy in accordance with the Financial Services Act, CONSOB Regulation No. 20307 of 15 February 2018 (as amended from time to time) and Legislative Decree No. 385 of 1 September 1993, as amended (the **Banking Act**); and
- (b) comply with any other applicable laws and regulations or requirement imposed by CONSOB, the Bank of Italy (including the reporting requirements, where applicable, pursuant to Article 129 of the Banking Act and the implementing guidelines of the Bank of Italy, as amended from time to time, and/or any other Italian authority).

### ***United States of America***

The applicable Final Terms will confirm whether the Issuer is Category 1, Category 2 or Category 3 for the purposes of Regulation S under the Securities Act.

The Notes have not been and will not be registered under the Securities Act or the securities laws of any state or other jurisdiction of the United States and may not be offered or sold within the United States or if Category 2 is specified in the Final Terms to, or for the account or benefit of, U.S. persons except in certain transactions exempt from, or subject to, the registration requirements of the Securities Act. Terms used in this paragraph have the meanings given to them by Regulation S.

The Notes do not require compliance with U.S. Treasury regulations under the United States Tax Equity and Fiscal Responsibility Act of 1982 ("**TEFRA**"). If Category 2 is specified in the Final Terms, each Dealer has severally agreed and each additional Dealer appointed under the Programme will be required to severally agree that, except as permitted by the Dealer Agreement, it will not offer, sell or deliver Notes (i) as part of their distribution at any time or (ii) otherwise until 40 days after the later of the date of commencement of the offering of the Notes and the issue date hereof, as certified to the Issuer by such Dealer (or, in the case of a sale of a Series to or through more than one Dealer, by each of such Dealers as to the Notes of such Series purchased by or through it, in which case the Issuer shall notify each such Dealer when all such Dealers have so certified) within the United States or to, or for the account or benefit of, U.S. persons, and such Dealer will be required to agree that it will send to each Dealer to which it sells Notes during the distribution compliance period relating thereto a confirmation or other notice setting forth the restrictions on offers and sales of the Notes within the United States or to, or for the account or benefit of, U.S. persons.

Accordingly, if Category 2 is specified in the Final Terms, the Notes are being offered and sold only outside the United States in offshore transactions in reliance on, and in compliance with, Regulation S.

In addition, until 40 days after the commencement of the offering of Notes comprising any Series, any offer or sale of Notes within the United States by any Dealer (whether or not participating in the offering) may violate the registration requirements of the Securities Act.

### ***Japan***

The Notes have not been and will not be registered under the Financial Instruments and Exchange Act of Japan (Act No. 25 of 1948), as amended (the "**FIEA**"). Accordingly, each Dealer has represented and agreed, and each further Dealer appointed under the Programme will be required to represent and agree, that it has not, directly or indirectly, offered or sold and will not, directly or indirectly, offer to sell any Notes in Japan or to, or for the benefit of, a resident of Japan (which term as used herein means any person resident in Japan, including any corporation or other entity organised under the laws of Japan) or to others for re-offering or resale, directly or indirectly, in Japan or to, or for the benefit of, any resident in Japan, except pursuant to an exemption from the registration requirements of, and otherwise in compliance with, FIEA and other relevant laws and regulations of Japan.

### ***United Kingdom***

Each Dealer has represented and agreed, and each further Dealer appointed under the Programme will be required to represent and agree, that:

- (a) in relation to any Notes which have a maturity of less than one year, (i) it is a person whose ordinary activities involve it in acquiring, holding, managing or disposing of investments (as principal or agent) for the purposes of its business and (ii) it has not offered or sold and will not offer or sell any Notes other than to persons whose ordinary activities involve them in acquiring, holding, managing or disposing of investments (as principal or as agent) for the purposes of their businesses or who it is reasonable to expect will acquire, hold, manage or dispose of investments (as principal or agent) for the purposes of their businesses where the issue of the Notes would otherwise constitute a contravention of Section 19 of the Financial Services and Markets Act 2000 (the "**FSMA**") by the Issuer;
- (b) it has only communicated or caused to be communicated and will only communicate or cause to be communicated an invitation or inducement to engage in investment activity (within the meaning of Section 21 of the FSMA) received by it in connection with the issue or sale of any Notes in circumstances in which Section 21(1) of the FSMA does not apply to the Issuer; and
- (c) it has complied and will comply with all applicable provisions of the FSMA with respect to anything done by it in relation to any Notes in, from or otherwise involving the United Kingdom.

### ***Prohibition of Sales to EEA Retail Investors***

Unless the Final Terms in respect of any Notes specifies the "Prohibition of Sales to EEA Retail Investors" as "Not Applicable", each Dealer has represented and agreed,

and each further Dealer appointed under the Programme will be required to represent and agree, that it has not offered, sold or otherwise made available and will not offer, sell or otherwise make available any Notes which are the subject of the offering contemplated by this Base Prospectus as completed by the Final Terms in relation thereto to any retail investor in the EEA. For the purposes of this provision the expression "retail investor" means a person who is one (or more) of the following:

- (a) a retail client as defined in point (11) of Article 4(1) of Directive 2014/65/EU (as amended, "**MiFID II**"); or
- (b) a customer within the meaning of Directive 2002/92/EC (as amended or superseded), where that customer would not qualify as a professional client as defined in point (10) of Article 4(1) of MiFID II.

If the Final Terms in respect of any Notes specifies "Prohibition of Sales to EEA Retail Investors" as "Not Applicable", each Dealer has represented and agreed, and each further Dealer appointed under the Programme will be required to represent and agree, that with effect from and including the date on which the Prospectus Directive is implemented in that Relevant Member State (the **Relevant Implementation Date**) it has not made and will not make an offer of Notes which are the subject of the offering contemplated by this Base Prospectus as completed by the final terms in relation thereto to the public in that Relevant Member State, except that it may, with effect from and including the Relevant Implementation Date, make an offer of such Notes to the public in that Relevant Member State:

- (a) at any time to any legal entity which is a qualified investor as defined in the Prospectus Directive; or
- (b) at any time to fewer than 150 natural or legal persons (other than qualified investors as defined in the Prospectus Directive) subject to obtaining the prior consent of the relevant Dealer or Dealers nominated by the Issuer for any such offer; or
- (c) at any time in any other circumstances falling within Article 3(2) of the Prospectus Directive,

provided that no such offer of Notes referred to in (a) to (c) above shall require the Issuer or any Dealer to publish a prospectus pursuant to Article 3 of the Prospectus Directive, or supplement a prospectus pursuant to Article 16 of the Prospectus Directive.

For the purposes of this provision:

the expression an **offer of Notes** to the public in relation to any Notes in any Relevant Member State means the communication in any form and by any means of sufficient information on the terms of the offer and the Notes to be offered so as to enable an investor to decide to purchase or subscribe the Notes, as the same may be varied in that Member State by any measure implementing the Prospectus Directive in that Member State;

the expression **Prospectus Directive** means Directive 2003/71/EC (as amended or superseded), and includes any relevant implementing measure in the Relevant Member State.



## **GENERAL INFORMATION**

### **Listing and Admission to Trading**

Application has been made to the Luxembourg Stock Exchange for the Notes issued under the Programme to be admitted to trading on the Regulated Market of the Luxembourg Stock Exchange and to be listed on the Official List of the Luxembourg Stock Exchange.

However, Notes may be issued pursuant to the Programme which will not be listed on the Luxembourg Stock Exchange or any other stock exchange or which will be listed on such stock exchange as the Issuer and the relevant Dealer(s) may agree.

The Luxembourg Stock Exchange's Regulated Market is a regulated market for the purposes of the Markets in Financial Instruments Directive (Directive 2014/65/EU).

### **Authorisations**

The establishment of the Programme was authorised by the resolution of the Board of Directors of the Issuer passed on 15 April 2015 which is valid and effective at the date hereof. The Issuer has obtained or will obtain from time to time all necessary consents, approvals and authorisations in connection with the issue and performance of the Notes.

### **Clearing of the Notes**

The Notes will be in bearer form and held in dematerialised form on behalf of the beneficial owners, until redemption or cancellation thereof, by Monte Titoli S.p.A. (with registered office and principal place of business at Piazza degli Affari 6, 20123 Milan, Italy), for the account of the relevant Monte Titoli Account Holders (including Euroclear and Clearstream, Luxembourg). The relevant Final Terms shall specify any other clearing system as shall have accepted the relevant Notes for clearance together with any further appropriate information. The Notes have been accepted for clearance by Monte Titoli S.p.A.

### **Common codes and ISIN numbers**

The appropriate common code and the International Securities Identification Number in relation to the Notes of each Series will be specified in the Final Terms relating thereto.

### **Use of proceeds**

Unless otherwise specified in the applicable Final Terms, the net proceeds of the issue of each Tranche of Notes will be used by the Issuer for its general funding purposes.

If a Tranche of Notes to be issued is described as “Green Bonds”, “Social Bonds” or “Sustainability Bonds”, the applicable Final Terms will describe the relevant projects to which the net proceeds of the Tranche of Notes will be applied or will make reference to the relevant bond framework that applies to the use of the net proceeds of the relevant Tranche of Notes.

## **The Representative of the Noteholders**

A Representative of the Noteholders for each Series of Notes shall be appointed by the Dealers in the Subscription Agreement entered into in connection with such Series and in accordance with the Dealer Agreement, at the time of issue of such Series of Notes and set out in the relevant Final Terms.

## **Legal Proceedings**

Save as disclosed in the section “Description of Cassa depositi e prestiti S.p.A. – Legal Proceedings” at pages 142 to 146 of this Base Prospectus, there are no governmental, legal or arbitration proceedings (including any such proceedings which are pending or threatened, to which the Issuer is aware) which may have, or have had during the 12 months prior to the date of this Base Prospectus, a significant effect on the financial position or profitability of the Issuer.

## **No material adverse and no significant change**

There has been no material adverse change in the prospects of the Issuer since 31 December 2018, nor has there been any significant change in the trading position or the financial position of the Issuer, since 31 December 2018.

## **Documents available for inspection**

For so long as the Programme remains in effect or any Notes shall be outstanding, copies and (where applicable) English translations of the following documents may be inspected during normal business hours at the specified office of the Principal Paying Agent for the time being in Milan, and copies of the documents referred below can be obtained free of charge from the Principal Paying Agent during normal business hours on request of the Noteholders, namely:

- (a) the Article 5 and By-laws (*Statuto*) of the Issuer;
- (b) the Agency Agreement;
- (c) the Programme Manual;
- (d) the non-consolidated audited annual financial statements (including the auditors' report thereon and notes thereto) of the Issuer in respect of the years as at and ended 31 December 2018 and 31 December 2017;
- (e) the consolidated audited financial statements (including the auditors' report thereon and notes thereto) of the Issuer in respect of the years as at and ended on 31 December 2018 and 31 December 2017;
- (f) the 2018 Base Prospectus;
- (g) this Base Prospectus together with any supplement to this Base Prospectus;
- (h) as necessary, reports, letters, balance sheets, valuations and statements of experts included or referred to in the Base Prospectus (other than consent letters); and

- (i) any Final Terms relating to Notes which are admitted to listing, trading and/or quotation by any listing authority, stock exchange and/or quotation system. In the case of any Notes which are not admitted to listing, trading and/or quotation by any listing authority, stock exchange and/or quotation system, copies of the relevant Final Terms will only be available for inspection by the relevant Noteholders.

### **Financial statements available**

For so long as the Programme remains in effect or any Notes shall be outstanding, copies and, where appropriate, English translations of the most recent publicly available audited annual financial statements and unaudited interim financial information of the Issuer may be obtained during normal business hours at the specified office of the Principal Paying Agent.

### **Certificate**

No request has been made for a certificate permitting offers to the public of the Notes in other member states of the European Union.

### **Publication on the Internet**

This Base Prospectus, any supplement thereto and the Final Terms will be available on the internet site of the Luxembourg Stock Exchange ([www.bourse.lu](http://www.bourse.lu)).

### **Auditors**

Each of the consolidated and non-consolidated financial statements of the Issuer have been audited without qualification for the years ended 31 December 2018 and 31 December 2017 by PricewaterhouseCoopers S.p.A., who have given, and have not withdrawn, their consent to the inclusion of their report in this Base Prospectus in the form and context in which it is included.

PricewaterhouseCoopers S.p.A. is registered under No. 119644 in the Register of Accountancy Auditors (*Registro Revisori Legali*) by the Italian Ministry of Economy and Finance, in compliance with the provisions of the Legislative Decree of 27 January 2010, No. 39. PricewaterhouseCoopers S.p.A., which is located at Via Monte Rosa 91, 20149 Milan, Italy, is also a member of ASSIREVI (the Italian association of audit firms).

### **Conditions for determining price**

The price and amount of Notes to be issued under the Programme will be determined by the Issuer and the relevant Dealer at the time of issue in accordance with prevailing market conditions.

### **Yield**

In relation to any Tranche of Fixed Rate Notes, an indication of the yield in respect of such Notes will be specified in the applicable Final Terms. The yield is calculated at the Issue Date of the Notes on the basis of the relevant Issue Price. The yield

indicated will be calculated as the yield to maturity as at the Issue Date of the Notes and will not be an indication of future yield.

### **2006 ISDA Definitions**

Investors should consult the Issuer should they require a copy of the 2006 ISDA Definitions.

### **Dealers transacting with the Issuer**

Certain of the Dealers and their affiliates (including parent companies) have engaged, and may in the future engage, in financing, in investment banking and/or commercial banking transactions with, and may perform services to the Issuer and its affiliates in the ordinary course of business. In addition, in the ordinary course of their business activities, the Dealers and their affiliates may make or hold a broad array of investments and actively trade debt and equity securities (or related derivative securities) and financial instruments (including bank loans) for their own account and for the accounts of their customers. Such investments and securities activities may involve securities and/or instruments of the Issuer or Issuer's affiliates. Certain of the Dealers or their affiliates that have a lending relationship with the Issuer routinely hedge their credit exposure to the Issuer consistently with their customary risk management policies. For the purpose of this paragraph the term "affiliates" includes also parent companies.

### **The Legal Entity Identifier**

The Legal Entity Identifier (LEI) code of the Issuer is 81560029E2CE4D14F425.

## REGISTERED OFFICE OF THE ISSUER

### CASSA DEPOSITI E PRESTITI S.P.A.

Via Goito, 4  
00185 Rome  
Italy

## JOINT ARRANGERS

### Cassa depositi e prestiti S.p.A.

Via Goito, 4  
00185 Rome  
Italy

### Barclays Bank PLC

5 The North Colonnade  
Canary Wharf  
London E14 4BB  
United Kingdom

## DEALERS

### Banca IMI S.p.A.

Largo Mattioli, 3  
20121 Milan  
Italy

### Deutsche Bank AG, London Branch

Winchester House  
1 Great Winchester Street  
London EC2N 2DB  
United Kingdom

### Barclays Bank Ireland PLC

One Molesworth Street  
Dublin 2  
DO2RF29  
Ireland

### HSBC France

103, avenue des Champs Elysees  
75008 Paris  
France

### Barclays Bank PLC

5 The North Colonnade  
Canary Wharf  
London E14 4BB  
United Kingdom

### J.P. Morgan Securities plc

25 Bank Street  
Canary Wharf  
London E14 5JP  
United Kingdom

### BNP Paribas

10 Harewood Avenue  
London NW1 6AA  
United Kingdom

### Mediobanca – Banca di Credito Finanziario S.p.A.

Piazzetta Enrico Cuccia, 1  
20121 Milan  
Italy

### BofA Securities Europe SA

51 rue La Boétie  
75008 Paris  
France

### Merrill Lynch International

2 King Edward Street  
London EC1A 1HQ  
United Kingdom

**Citigroup Global Markets Europe AG**  
Reuterweg 16 Frankfurter Welle 60323  
Frankfurt  
Federal Republic of Germany

**Morgan Stanley & Co. International plc**  
25 Cabot Square  
Canary Wharf  
London E14 4QA  
United Kingdom

**Citigroup Global Markets Limited**  
Citigroup Centre Canada Square  
Canary Wharf  
London E14 5LB  
United Kingdom

**MPS Capital Services Banca per le  
Imprese S.p.A.**  
Via Leone Pancaldo, 4  
50127 Firenze  
Italy

**Commerzbank Aktiengesellschaft**  
Kaiserstrasse 16 (Kaiserplatz)  
60311 Frankfurt am Main  
Germany

**Nomura International plc**  
1 Angel Lane  
London EC4R 3AB  
United Kingdom

**Crédit Agricole Corporate and  
Investment Bank**  
12, Place des Etats-Unis  
CS 70052, 92547 MONTROUGE  
CEDEX  
France

**Société Générale**  
29 boulevard Haussmann  
75009 Paris  
France

**Credit Suisse Securities (Europe)  
Limited**  
One Cabot Square  
London E14 4QJ  
United Kingdom

**UBS Europe SE**  
Bockenheimer Landstraße 2-4  
60306 Frankfurt am Main  
Germany

**UniCredit Bank AG**  
Arabellastrasse 12  
81925 Munich  
Germany

#### **PRINCIPAL PAYING AGENT**

**BNP Paribas Securities Services**  
Piazza Lina Bo Bardi, 3  
20124 Milan  
Italy

#### **LISTING AGENT**

**BNP Paribas Securities Services**  
60 avenue J.F. Kennedy  
L-1855 Luxembourg

## LEGAL ADVISERS

*To the Issuer:*

**Allen & Overy Studio Legale  
Associato**  
Corso Vittorio Emanuele II, 284  
00186 Rome  
Italy

*To the Joint Arrangers and the Dealers:*

**Clifford Chance Studio Legale  
Associato**  
Piazzetta M. Bossi, 3  
20121 Milano  
Italy

## AUDITORS TO THE ISSUER

**PricewaterhouseCoopers S.p.A.**  
Via Monte Rosa, 91  
20149 Milan  
Italy